

Стандартные концевые выключатели ХС

Технические характеристики

По вопросам продаж и поддержки обращайтесь:

Алматы (727)345-47-04
Ангарск (3955)60-70-56
Архангельск (8182)63-90-72
Астрахань (8512)99-46-04
Барнаул (3852)73-04-60
Белгород (4722)40-23-64
Благовещенск (4162)22-76-07
Брянск (4832)59-03-52
Владивосток (423)249-28-31
Владикавказ (8672)28-90-48
Владимир (4922)49-43-18
Волгоград (844)278-03-48
Вологда (8172)26-41-59
Воронеж (473)204-51-73
Екатеринбург (343)384-55-89

Иваново (4932)77-34-06
Ижевск (3412)26-03-58
Иркутск (395)279-98-46
Казань (843)206-01-48
Калининград (4012)72-03-81
Калуга (4842)92-23-67
Кемерово (3842)65-04-62
Киров (8332)68-02-04
Коломна (4966)23-41-49
Кострома (4942)77-07-48
Краснодар (861)203-40-90
Красноярск (391)204-63-61
Курск (4712)77-13-04
Курган (3522)50-90-47
Липецк (4742)52-20-81

Магнитогорск (3519)55-03-13
Москва (495)268-04-70
Мурманск (8152)59-64-93
Набережные Челны (8552)20-53-41
Нижний Новгород (831)429-08-12
Новокузнецк (3843)20-46-81
Ноябрьск (3496)41-32-12
Новосибирск (383)227-86-73
Омск (3812)21-46-40
Орел (4862)44-53-42
Оренбург (3532)37-68-04
Пенза (8412)22-31-16
Петрозаводск (8142)55-98-37
Псков (8112)59-10-37
Пермь (342)205-81-47

Ростов-на-Дону (863)308-18-15
Рязань (4912)46-61-64
Самара (846)206-03-16
Санкт-Петербург (812)309-46-40
Саратов (845)249-38-78
Севастополь (8692)22-31-93
Саранск (8342)22-96-24
Симферополь (3652)67-13-56
Смоленск (4812)29-41-54
Сочи (862)225-72-31
Ставрополь (8652)20-65-13
Сургут (3462)77-98-35
Сыктывкар (8212)25-95-17
Тамбов (4752)50-40-97
Тверь (4822)63-31-35

Тольятти (8482)63-91-07
Томск (3822)98-41-53
Тула (4872)33-79-87
Тюмень (3452)66-21-18
Ульяновск (8422)24-23-59
Улан-Удэ (3012)59-97-51
Уфа (347)229-48-12
Хабаровск (4212)92-98-04
Чебоксары (8352)28-53-07
Челябинск (351)202-03-61
Череповец (8202)49-02-64
Чита (3022)38-34-83
Якутск (4112)23-90-97
Ярославль (4852)69-52-93

Россия +7(495)268-04-70

Казахстан +(727)345-47-04

Беларусь +(375)257-127-884

Узбекистан +998(71)205-18-59

Киргизия +996(312)96-26-47

эл.почта: tuq@nt-rt.ru || сайт: <https://telemecanique.nt-rt.ru>

Selection guidepage 2

- **Variable composition:** Simplicity through innovation page 16
- **General** page 18

XC Standard

- **Miniature design, metal, XCMD**
 - Presentation page 26
 - Pre-cabled page 28
 - Integral or remote connector page 36
 - Separate components page 49
- **Miniature design for mobile equipment, metal, XCMV**
 - Presentation page 50
 - Complete units with connector page 53
 - Modular units with connector page 56
 - Pre-cabled modular units page 62
- **Compact design, plastic, XCKP**
 - Presentation page 76
 - Complete units with 1 cable entry page 78
 - Integral M12 connector page 82
- **Compact design, metal, XCKD**
 - Presentation page 76
 - Complete units with 1 cable entry page 84
 - Integral M12 connector page 88
- **Compact design, plastic, XCKT**
 - Presentation page 76
 - Complete units with 2 cable entries page 90
- **Compact design, XCKD, XCKP and XCKT**
 - Presentation page 76
 - Variable composition page 92
 - Adaptable sub-assemblies: bodies, contacts page 94

XC Standard, with reset

- **Compact design, plastic, XCPR**
 - Presentation page 98
 - Complete switches with 1 cable entry page 100
- **Compact design, plastic, XCTR**
 - Presentation page 98
 - Complete switches with 2 cable entries page 102

XC Basic

- Miniature design, plastic, XCMH - Presentation *page 68*
 - Complete units, pre-cabled *page 70*
- Compact design, plastic, XCKN and XCNT - Presentation *page 104*
 - Complete units with 1 cable entry *page 106*
 - Complete units with 2 cable entries *page 108*
- Compact design, with reset, XCNR - Presentation *page 110*
 - Complete units with 1 cable entry *page 112*

XC Standard, “Classic” format

- Metal, XCKM - Presentation *page 114*
 - Complete switches with 3 cable entries *page 116*
- Metal, XCKL - Presentation *page 114*
 - Complete switches incorporating cable gland *page 118*
- Metal, 2 x 2-pole contacts, XCKML - Presentation *page 114*
 - Complete switches with 3 cable entries *page 120*
- Metal, XCKM and XCKL
 - Variable composition *page 122*
 - Adaptable sub-assemblies *page 124*

XC Standard, EN 50041 format

- Plastic, double insulated, XCKS - Presentation *page 130*
 - Complete switches with 1 cable entry *page 132*
 - Variable composition *page 136*
 - Adaptable sub-assemblies: bodies, contact blocks *page 138*

XC Standard, industrial EN 50041 format

- Metal, XCKJ - Presentation *page 142*
 - Complete switches
 - Fixed body with 1 cable entry *page 144*
 - Fixed body with 1 integral M12 connector *page 148*
 - Fixed body with 1 integral 7/8”16 UN connector *page 150*
 - Variable composition: standard bodies, fixed or plug-in *page 152*
 - Adaptable sub-assemblies
 - Bodies, contact blocks *page 154*
 - For low temperature applications (- 40 °C) *page 164*
 - For high temperature applications (+ 120 °C) *page 167*

- **Product reference index** *page 170*

Limit switches

XC Standard range

Design/Applications	Miniature format	Miniature format for mobile equipments	Compact format, CENELEC EN 50047
	Metal, pre-cabled	Metal, pre-cabled	Plastic, 1 cable entry



Enclosure	Metal	Metal	Plastic, double insulated
Modularity	Head, body and connection modularity	Head and body modularity	Head, body and cable entry modularity
Conformity/Certifications	CE, UL, CSA, CCC, EAC	CE, UL, CSA	CENELEC EN 50047 UL, CSA, CCC, EAC
Body dimensions (w x h x d) in mm	30 x 50 x 16	30 x 50 x 20.5	31 x 65 x 30
Head	Linear movement (plunger) Rotary movement (lever) Rotary movement, multidirectional Same heads for ranges XCMD, XCMV, XCKD, XCKP and XCKT		
Contact blocks	2 electrically separate contacts	<ul style="list-style-type: none"> • snap action with positive opening operation • slow break with positive opening operation 	<ul style="list-style-type: none"> • •
	2 same polarity contacts	<ul style="list-style-type: none"> – snap action – slow break 	<ul style="list-style-type: none"> – –
3 electrically separate contacts	<ul style="list-style-type: none"> • snap action with positive opening operation • slow break with positive opening operation 	<ul style="list-style-type: none"> – – 	<ul style="list-style-type: none"> • •
	4 electrically separate contacts	<ul style="list-style-type: none"> • snap action with positive opening operation – slow break with positive opening operation 	<ul style="list-style-type: none"> – –
4 contacts (2 x 2 same polarity contacts)	<ul style="list-style-type: none"> – snap action 	<ul style="list-style-type: none"> • 	<ul style="list-style-type: none"> –
Degree of protection IP/IK	IP 66, IP 67, IP 68, IK 06	IP 66, IP 67, IP 69, IK 04, IK 06 depending on model	IP 66, IP 67, IK 04,
Operating temperature	- 25 °C... + 70 °C, -40°C depending on heads		
Raccordement	Screw terminals	–	1 entry for ISO M16 or M20, Pg 11, Pg 13.5 cable gland or 1/2" NPT, PF 1/2
	Pre-cabled	Ø 7.5 PvR, CEI, halogen free, depending on model	Ø 6,4 PvR
	Connector	Integral or remote M12 or remote 7/8"-16UN	M12, Deutsch DT04-4P or AMP Superseal 1.5
Type reference	XCMD	XCMV	XCKP
Pages	28	50	78 and 82

Compact format, CENELEC EN 50047		Compact format, with reset	
Plastic, 2 cable entries	Metal, 1 cable entry	Plastic, 1 cable entry	Plastic, 2 cable entries



Plastic, double insulated	Metal	Plastic, double insulated	
Head and body modularity	Head, body and connection modularity	–	
CENELEC EN 50047, UL, CSA, CCC, EAC		CE, UL, CSA, EAC	
58 x 51 x 30	31 x 65 x 30	31 x 65 x 30	58 x 51 x 30
Linear movement (plunger) Rotary movement (lever) Rotary movement, multidirectional Same heads for ranges XCMD, XCMV, XCKD, XCKP and XCKT		Linear movement (plunger) Rotary movement (lever)	
•	•	•	•
•	•	•	•
–	–	–	–
–	–	–	–
•	•	–	–
•	•	–	–
–	–	–	–
–	–	–	–
–	–	–	–
IP 66, IP 67, IK 04	IP 66, IP 67, IK 06	IP 66, IP 67, IK 04	
- 25 °C... + 70 °C			
2 entries for ISO M16 or Pg 11 cable gland or 1/2" NPT (using adaptor)	1 entry for ISO M16 or M20, Pg 11, Pg 13.5 cable gland or 1/2" NPT, PF 1/2	1 entry for ISO M20 or Pg 13.5 cable gland or 1/2" NPT	2 entries for ISO M16 or Pg 11 cable gland or 1/2" NPT (using adaptor)
–	–	–	–
–	M12	–	–
XCKT	XCKD	XCPR	XCTR
90	84 and 88	100	102

Limit switches

XC Standard range

Design	"Classic" format		Industrial EN 50041 format	
	Metal, 3 cable entries	Metal, 1 cable entry	Plastic, 1 cable entry	Metal, 1 cable entry or connector
				
Enclosure	Metal		Plastic, double insulated	Metal
Modularity	Head, body and operator modularity			
Conformity/Certifications	CÉ, UL, CSA, CCC, EAC	CÉ, UL, CSA, EAC	CENELEC EN 50041 UL, CSA, CCC, EAC	
Body dimensions (w x h x d) in mm	63 x 64 x 30	52 x 72 x 30	40 x 72.5 x 36	40 x 77 x 44 42.5 x 84 x 36
Head	Linear movement (plunger) Rotary movement (lever) Rotary movement, multidirectional			
Contact blocks				
2 electrically separate contacts	snap action with positive opening operation	•	•	•
	slow break with positive opening operation	•	•	•
2 same polarity contacts	snap action	–	–	•
	slow break	–	–	–
3 electrically separate contacts	snap action with positive opening operation	•	•	•
	slow break with positive opening operation	•	•	•
4 electrically separate contacts	snap action with positive opening operation	–	–	–
	slow break with positive opening operation	–	–	–
4 contacts (2 x 2 same polarity contacts)	snap action	–	•	•
Degree of protection IP/IK	IP 66, IK 06		IP 65, IK 03	IP 66, IK 07
Operating temperature	- 25°C... + 70°C			- 25°C... + 70°C - 40°C or + 120°C depending on model
Connection	Screw terminals (entry for cable gland)	3 entries for ISO M20, Pg 11 cable gland or 1/2" NPT	1 entry incorporating cable gland or tapped 1/2" NPT	1 entry for ISO M20, Pg 13.5 cable gland or 1/2" NPT
	Pre-cabled	–		
	Connector	–		Integral M12 or 7/8"-16UN
Type reference	XCKM	XCKL	XCKS	XCKJ
Pages	114	114	130	142

Miniature format	Compact format EN 50047		Compact format, with reset knob
Plastic, pre-cabled	Plastic, 1 cable entry	Plastic, 2 cable entries	Plastic, 1 cable entry



Plastic, double insulated			
-			
CE, cULus, CCC	GENELEC EN 50047, UL, CSA, CCC, EAC		CE, UL, CSA, CCC, EAC
30 x 50 x 16	31 x 65 x 30	59 x 51 x 30	31 x 65 x 30
Linear movement (plunger) Rotary movement (lever) Rotary movement, multidirectional			
•	•	•	•
-	•	•	•
•	-	-	-
-	-	•	-
-	•	-	•
-	•	-	•
-	-	-	-
-	-	-	-
-	-	-	-
IP 66, IP 67, IK 04			
-25 °C... +70 °C			
-	1 entry for ISO M20 or Pg 11 cable gland Other cable entries: ISO M16 x 1.5 or PF 1/2 (G1/2)	2 entries for ISO M16 or Pg 11 cable gland or 1/2" NPT (using adaptor)	1 entry for ISO M20 or Pg 11 cable gland Other cable entries: ISO M16 x 1.5 or PF 1/2 (G1/2)
Ø 4.2 mm PvR, lateral or axial cable output, depending on model			
XCMH	XCKN	XCNT	XCNR
68	106	108	112

Limit switches

XC Special range

Design/Applications	Very severe applications	For hoisting and material handling applications (XCR); for conveyor belt shift monitoring (XCRT)	For hoisting and material handling applications	Subminiature format and microswitch. Applications requiring high precision and a low operating force
	Metal, 1 cable entry	Metal or polyester, 1 cable entry	Metal or plastic, 3 cable entries	Plastic, pre-cabled



Enclosure	Metal	Metal or polyester	Metal or plastic	Polyester
Modularity	Head and body modularity	–	–	–
Conformity/Certifications	CE, UL, CSA, EAC	CE, CSA (XCR) CCC (XCR), EAC	CE, UL, CSA, CCC, EAC	CE, UL
Body dimensions (w x h x d) in mm	40 x 81 x 41	85 x 95 x 75	118 x 77 x 59 (metal) 118 x 77 x 67 (plastic)	Depending on model
Head	Linear movement (plunger) or rotary movement (lever)	Rotary movement (lever)	Rotary movement (lever)	–
Contact blocks				
2 same polarity contacts snap action	●	–	–	●
4 electrically separate contacts snap action with positive opening operation	–	●	–	–
slow break with positive opening operation	–	●	●	–
4 contacts (2 x 2 same polarity contacts), snap action	●	●	–	–
Degree of protection IP/IK	IP 65, IK 08	IP 54, IK 07 or IP 65, depending on model	IP 66, IK 07 (metal) IP 65, IK 04 (plastic)	IP 67 or IP 40 depending on model IP 00 (tags)
Operating temperature	-25°C... +70°C; -40°C or +120°C (XC2J depending on model)	-25°C... +70°C	-25°C... +70°C	-40°C... +105°C, -40°C... +125°C selon modèle
Connection				
Screw terminals (entry for cable gland)	1 entry with integral cable gland	1 tapped entry for Pg 13.5 cable gland	3 tapped entries for Pg 13.5 cable gland or tapped M20 x 1.5, depending on model	Tag connections or pre-wired, depending on model
Type reference	XC2J	XCR XCRT	XCKMR XCKVR	XEP
Catalogue	Limit switches - XC Special range			

Design/Applications	Overtravel limit switches for power circuits For hoisting applications
	Aluminium alloy case or sheet steel enclosure 2 or 3 cable entries



Enclosure	Aluminium alloy case		Sheet steel enclosure
Reset	Manual		Manual or automatic, depending on model
Conformity/Certifications	CSA, IEC 60158-1, NF C 63-110, VDE 0660, IEC 947-1, IEC 60947-4		
Body dimensions (w x h x d) in mm	Depending on model		
Head	Rotary movement		
Number of poles	4		3
Rated operational current (Ie)	For 2-pole scheme	50 A or 130 A, depending on model	–
	For 3-pole scheme on AC-3	25 A or 65 A, depending on model	115 A, 185 A or 265 A, depending on model
Conventional thermal current (Ithe) at 0 ≤ 40 °C	For 2-pole scheme	80 A or 160 A, depending on model	–
	For 3-pole scheme	40 A or 80 A, depending on model	200 A, 275 A or 350 A, depending on model
Rated insulation voltage (Ui)	Conforming to IEC 60158-1, IEC 947-4, VDE 0110 Group C	500 V	660 V
	Conforming to CSA 22-2 n° 14	600 V	600 V
Rated breaking capacity	Conforming to IEC 60158-1	400 A or 1000 A, depending on model	1100 A, 1600 A or 2200 A, depending on model
	For 2-pole scheme	180 A or 630 A, depending on model	900 A, 1200 A or 1750 A, depending on model
Degree of protection	IP 54		IP 43
Operating temperature	- 25 °C... + 70 °C		- 25 °C... + 70 °C
Cable entry	2 tapped entries for n° 21 cable gland or 3 tapped entries for n° 29 cable gland, depending on model		2 entries incorporating n° 36 plastic cable gland
Type reference	XF9D		XF9F
Catalogue	Limit switches - XC Special range		

Switch type	XCS safety limit switches	
Applications	Protection of operators by stopping the machine when the gate is opened. All machines with quick rundown time.	
Design	Miniature format	Compact format
	Pre-cabled	With 1 cable entry



Case		Metal	Plastic	Metal
Features		-		
Conformity to standards	Products Machine assemblies	EN/IEC 60947-5-1, EN/ISO 13849-1, EN/IEC 62061, UL 508, CSA C22-2 no. 14 EN/IEC 60204-1, EN/ISO 14119		
Product certifications		UL, CSA, CCC, EAC		
Dimensions (w x h x d) in mm	Switch Fixings Centers	30 x 50 x 16 20	31 x 34 x 89 20/22	
Head		Plunger or rotary head Head adjustable in 15° steps through 360° Linear (plunger) or rotary (lever) actuation.		
Contact blocks		NC contacts with positive opening operation		
		2 NC + 1 NO break before make, slow break 2 NC + 1 NO and 2 NC + 2 NO snap action	XCSD: 2 NC + 1 NO break before make, slow break or snap action XCSP: 2 NC + 1 NO snap action	
Degree of protection		IP 66, IP 67 and IP 68	IP 66 and IP 67	
Ambient air temperature	For operation	-25...+70 °C		
Connection	Screw terminals (cable entry via cable gland) Pre-cabled	-	Tapped entry for Pg 13.5, ISO M20 cable gland or tapped 1/2" NPT	
Type reference		L = 1, 2 or 5 m		
Catalogue		XCSM	XCSP	XCSD
		Safety switches - XCS range		

XCS lever or spindle-operated safety switches

Protection of operators by stopping the machine when the operating lever (attached to hinged machine guard) is displaced by 5°.
All light industrial machines fitted with hinged or rotary protective covers with small opening radius.

Protection of operators by stopping the machine when the guard hinge rotates through 5°.
All light industrial machines fitted with hinged access doors.

Compact format

With 1 or 2 cable entries



Plastic, double insulated

2 types of lever: straight or elbowed (flush with rear of switch)
3 lever positions: to left, center or to right

2 types of spindle: length 30 mm or 80 mm

EN/IEC 60947-5-1, EN/ISO 13849-1, EN/IEC 62061, UL 508, CSA C22-2 no.14, JIS C4520

EN/IEC 60204-1, EN/ISO 14119

UL, CSA, CCC, EAC

30 x 87.5 x 30

30 x 96 x 30

52 x 117 x 30

20/22

20/22

20/22 or 40.3

Turret head: 4 positions
Rotary actuation (lever)

Turret head: 4 positions
Rotary actuation (spindle)

Slow break safety contacts with positive opening operation
NC contacts open when lever or spindle displaced by more than 5°

1 NC + 1 NO break before make
2 NC
1 NC + 2 NO break before make
2 NC + 1 NO break before make

1 NC + 1 NO break before make
2 NC
1 NC + 2 NO break before make
2 NC + 1 NO break before make

1 NC + 2 NO break before make
2 NC + 1 NO break before make
3 NC

IP 67

-25...+70 °C

1 tapped entry for Pg 11, ISO M16 cable gland or tapped 1/2" NPT

1 tapped entry for Pg 11, ISO M16 cable gland or tapped 1/2" NPT

2 tapped entries for Pg 11, ISO M16 cable gland or tapped 1/2" NPT

XCSPL

XCSPR

XCSTR

Switch type	XCS key-operated safety switches		
Applications	Protection of operators by stopping the machine when the actuating key (attached to machine guard) is withdrawn from the head of the switch. All light industrial machines with quick rundown time (1).		
Design	Miniature format	Compact format	
	Pre-cabled	With 1 or 2 cable entries	
			
Features	Without locking of actuating key.		
Conformity to standards	Without locking of actuating key. Optional accessory: guard retaining device.		
Product certifications	EN/IEC 60947-5-1, EN/ISO 13849-1, EN/IEC 62061, UL 508, CSA C22-2 no. 14 EN/IEC 60204-1, EN/ISO 14119		
Dimensions (w x h x d) in mm	cULus	UL, CSA, CCC, EAC	
Head	30 x 87 x 15	30 x 93.5 x 30	52 x 114.5 x 30
Contact blocks	Centers: 20/22	Centers: 20/22	Centers: 20/22 or 40.3
Degree of protection	Fixed head: 2 positions for insertion of actuating key.	Turret head: 8 positions for insertion of actuating key.	
Ambient air temperature	Safety contacts actuated by the actuating key. Slow break and NC positive opening operation.		
Connection	1 NC + 1 NO break before make 2 NC 2 NC + 1 NO break before make 3 NC	1 NC + 1 NO slow break contacts, break before make or make before break, or snap action 2 NC slow break or snap action 2 NC + 1 NO slow break contacts, break before make, or snap action 1 NC + 2 NO slow break contacts, break before make, or snap action	1 NC + 2 NO break before make 2 NC + 1 NO break before make 3 NC
Type reference	IP 67	-	
Catalogue	-25...+70 °C	-	
	-	Tapped entry for Pg 11, ISO M16 cable gland or tapped 1/2" NPT	
	L = 2, 5 or 10 m	-	-
	XCSMP	XCSPA	XCSTA
	Safety switches - XCS range		

(1) Machine stopping time less than time taken for operator to access hazardous zone.

XCS key-operated safety switches

All heavy industrial machines with quick rundown time (1)

Industrial format with or without locking

With 1 cable entry, without locking

With 1 cable entry and manual locking/unlocking



Without locking of actuating key.

Manual locking and unlocking of actuating key by pushbutton (can be mounted on left or right-hand side of switch head).

Manual locking and unlocking of actuating key by key-operated lock (can be mounted on left or right-hand side of switch head).

EN/IEC 60947-5-1, EN/ISO 13849-1, EN/IEC 62061, UL 508, CSA C22-2 no.14

EN/IEC 60204-1, EN/ISO 14119

UL, CSA, CCC, EAC

40 x 113.5 x 44

52 x 113.5 x 44

30 x 60

30 x 60

Turret head: 8 positions for insertion of actuating key.

Turret head: 8 positions for insertion of actuating key.

Safety contacts actuated by the actuating key. Slow break and NC positive opening operation.

Safety contacts actuated by the actuating key. Slow break and NC positive opening operation.

1 NC + 2 NO break before make
2 NC + 1 NO break before make
3 NC

1 NC + 2 NO break before make
2 NC + 1 NO break before make
3 NC

IP 67

-25...+70 °C

Screw clamp terminals. Tapped entry for Pg 13.5, ISO M20 cable gland or tapped 1/2" NPT

Screw clamp terminals. Tapped entry for Pg 13.5 cable gland, ISO M20 or tapped 1/2" NPT.

XCSA

XCSB

XCSC

Switch type
Applications
Design

XCS key-operated safety switches, locking and unlocking by solenoid	
Protection of operators by stopping the machine when the actuating key (attached to machine guard) is withdrawn from the head of the switch. All industrial machines with long rundown time ⁽¹⁾	
Slim format	
With 3 cable entries	With 3 cable entries



Case	
Features	
Conformity to standards	Products Machine assemblies
Product certifications	
Dimensions (w x h x d or Ø) in mm	Switch Fixings Centers
Head	
Resistance to forcible withdrawal of the actuator	F _{1max} F _{Zh}
Contact blocks or outputs	Main contacts Auxiliary contacts
Degree of protection	
Ambient air temperature	For operation For storage
Connection	Terminals Connector
Type reference	
Catalogue	

Plastic	Metal
Locking and unlocking of actuating key using a solenoid (either on energization or on de-energization). Manual unlocking (auxiliary release using special tool) of actuating key in abnormal conditions.	Locking and unlocking of actuating key by solenoid (either on energization or on de-energization). Manual unlocking (auxiliary release using key lock) of actuating key in abnormal conditions. ¹ Emergency release mushroom head pushbutton (only for XCSLF●●●●4●● and XCSLF●●●●6●●).
EN/IEC 60947-5-1, EN/ISO 13849-1, EN/IEC 62061, UL 508 and CSA C22-2 no. 14	
EN/IEC 60204-1, EN/ISO 14119	
UL, CSA, CCC, EAC	
51 x 205 x 43.5	
30 x 153.3	
Turret head: 8 positions for insertion of actuating key.	
1400 N	3000 N
1100 N	2300 N
Main safety contacts actuated by the actuating key; auxiliary contacts actuated by solenoid. Contact states given with key inserted and solenoid not energized. Slow break and NC positive opening operation	
1 NC + 1 NO break before make 2 NC 1 NC + 2 NO break before make 2 NC + 1 NO break before make 3 NC	
1 NC + 1 NO break before make 2 NC 1 NC + 2 NO break before make 2 NC + 1 NO break before make 3 NC	
IP 66/IP 67	
-25...+60 °C	
-40...+70 °C	
Spring terminals, 3 cable entries. Tapped entry for ISO M20 cable gland or tapped 1/2" NPT.	
M23 (18 + 1 PE)	
XCSLE	XCSLF
Safety switches - XCS range	

(1) Machine stopping time greater than time taken for operator to access hazardous zone.

XCS key-operated safety switches, locking and unlocking by solenoid (continued)

Protection of operators by stopping the machine when the actuating key (attached to machine guard) is withdrawn from the head of the switch. All industrial machines with long rundown time (1)

Rectangular

– With 2 cable entries



Plastic, double insulated	Metal
Locking and unlocking of actuator by solenoid (either on de-energization or on energization). Manual unlocking (auxiliary release using special tool) of actuating key in abnormal conditions.	Locking and unlocking of actuating key by solenoid (either on energization or on de-energization). Manual unlocking (auxiliary release using key lock) of actuating key in abnormal conditions.
EN/IEC 60947-5-1, EN/ISO 13849-1, UL 508, CSA C22-2 no. 14, EN/IEC 62061, EN/IEC 60947-1	
EN/IEC 60204-1, EN/ISO 14119	
UL, CSA, CCC, EAC	UL, CSA, CCC, EAC
110 x 93.5 x 33	98 x 146 x 44
30 x 153.3	88 x 95
Turret head: 8 positions for insertion of actuating key	
650 N	2600 N
500 N	2000 N
Main safety contacts actuated by the actuating key; auxiliary contacts actuated by solenoid. Slow break and NC positive opening operation	
1 NC + 1 NO break before make 1 NC + 1 NO make before break 2 NC	1 NC + 2 NO break before make 2 NC + 1 NO break before make 3 NC
1 NC	1 NC + 1 NO 2 NC
IP 67	
-25...+60 °C	-25...+40 °C
-40...+70 °C	-40...+70 °C
Tapped entry for Pg 11 ISO M16 cable gland or tapped 1/2" NPT	Screw clamp terminals. 2 tapped entries for Pg 13.5 ISO M20 cable gland or tapped 1/2" NPT.
–	–
XCSTE	XCSE

Switch type	XCSR contactless RFID safety switches
Applications	Highly tamper-proof protection of operators by stopping the machine when the gate is opened (transfer lines, assembly lines, automated equipment, machine tools, etc.). All light industrial machines fitted with access gates with imprecise guidance and/or subjected to frequent washing, shocks and vibrations. This safety switch is suitable for machine with low inertia.
Design	Rectangular format M12 connector



Case	Thermoplastic housing (Valox TM)		
Features	Contactless system composed of a microprocessor-controlled switch and a transponder factory-paired with a unique code. Multiposition sensor transponder.		
	Assured operating sensing distance (Sao)	15 mm	
	Assured release distance (Sar)	35 mm	
	Type of switch	Standalone RFID switch	Daisy-chain RFID switch for direct series connection
	Operating mode	Single RFID switch for point-to-point connection	
Conformity to standards	Products	Possible functioning without association with a safety control unit (Integrated External Device Monitoring (EDM) and Start/Restart function)	
	Machine assemblies	Functioning in combination with a safety control unit PL=e/Cat4 - SIL 3	
	RFID protocol	EN/IEC 60947-5-2, EN/IEC 60947-5-3, UL 508, CSA C22.2 SIL 3 (IEC 61508), SILCL 3 (IEC 62061), PLe-Cat. 4 (EN ISO 13849-1)	
Product certifications		EN/IEC 60204-1, EN/ISO 14119	
Dimensions (w x h x d or Ø) in mm		Based on ISO 15693	
	Switch	CE, cULus, TÜV, FCC, EAC, IC, RCM, E2, ECOLAB	
	Transponder	30 x 108.3 x 15	30 x 118.6 x 5
	Fixings	30 x 108.3 x 15	
	Centers	50 x 15 x 15	
	Reader	-	
	Transponder	74...78	
Contact blocks or outputs	Safety output	30...34	
	Contact states given in presence of magnet	2 OSSDs (Safety outputs PNP NO). OSSDs are in the ON state when the gate is closed	
		Maximum current 400mA	Maximum current 200 mA
Degree of protection		-	
	Conforming to EN/IEC 60529	IP 65, IP 66, IP 67	
	Conforming to DIN 40050	IP 69K	
Ambient air temperature	For operation	-25...+70 °C	
	For storage	-40...+85 °C	
Connection	Pre-cabled	-	
	Connector	-	
	Conforming to EN/IEC 60947-5-2-A3 and EN/IEC 61076	1 M12 8-pin connector (A coding)	2 M12 5-pin connector (A coding)
Type reference		XCSR C•1•M12	XCSR C•2M12
Catalogue			XCSR C•0M12
		Safety switches - XCS range	

XCS safety coded magnetic safety switches for detection without contact

Protection of operators by stopping the machine when the gate is opened
 All light industrial machines fitted with access gates with imprecise guidance and/or subjected to frequent washing
 This Safety sensor is suitable for machine with low inertia.

Miniature rectangular format	Compact rectangular format	Cylindrical format
Pre-cabled or M8 connector on flying lead	Pre-cabled or M12 connector on flying lead	



Plastic		1 approach direction
3 approach directions		
5 mm	8 mm	
15 mm	20 mm	
-		
-		
EN/IEC 60947-5-1, EN/ISO 13849-1, EN/IEC 62061, UL 508 and CSA C22-2 no. 14		
EN/IEC 60204-1, EN/ISO 14119		
-		
UL, CSA, EAC, ECOLAB		
16 x 51 x 7	25 x 88 x 13	Ø 30, L 38.5
-		
16	78	-
-		
-		
-		
1 NC + 1 NO staggered 2 NC staggered Independent Reed-type contacts operated by coded magnet.	1 NC + 1 NO staggered 2 NC staggered 2 NC + 1 NO (NC staggered) 1 NC + 2 NO (NO staggered)	1 NC + 1 NO staggered 2 NC staggered
To be used with safety control units.		
IP 66 and IP 67 for pre-cabled version, IP 67 for connector on flying lead version		
-		
-		
-25...+85 °C		
-		
L = 2, 5 or 10 m		
M8, on 0.15 m flying lead	M12, on 0.15 m flying lead	
-		
-		
XCSDMC	XCSDMP	XCSDMR

Limit switches

XC range

Variable composition: simplicity through innovation

Principle

Variable composition principle

■ The Miniature design XCMD and XCMV, and Compact design XCKD, XCKP and XCKT ranges benefit from the variable composition concept.

■ A worldwide detection first for improving productivity.

A complete offer for resolving the most commonly encountered detection problems:

- product selection simplified,
- product availability simplified,
- installation and setting-up simplified,
- maintenance simplified.

Heads

■ A single metal operating head type for the Miniature design XCMD and XCMV, and Compact design XCKD, XCKP and XCKT ranges.

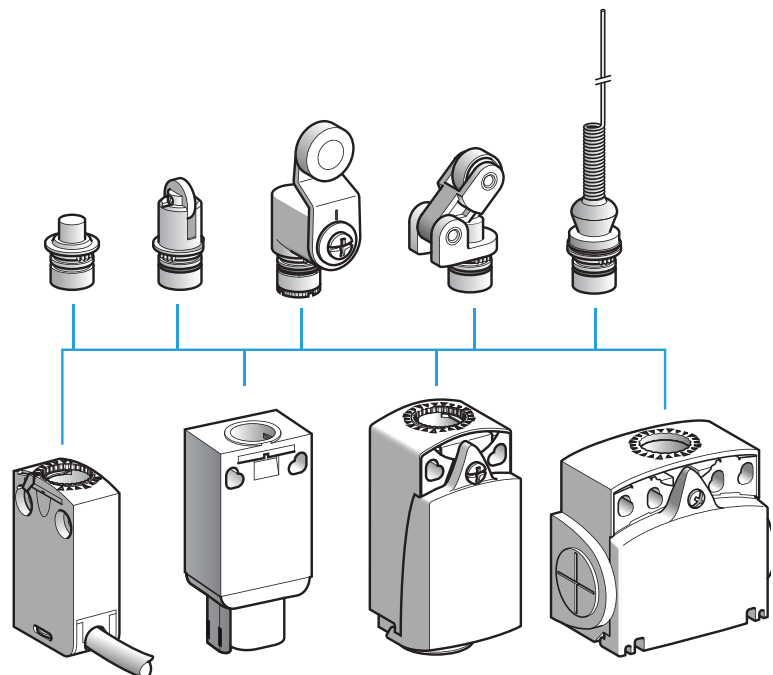

■ Interchanging of heads achieved by simple operation of forked metal latch.

■ Adjustable in 3 planes:

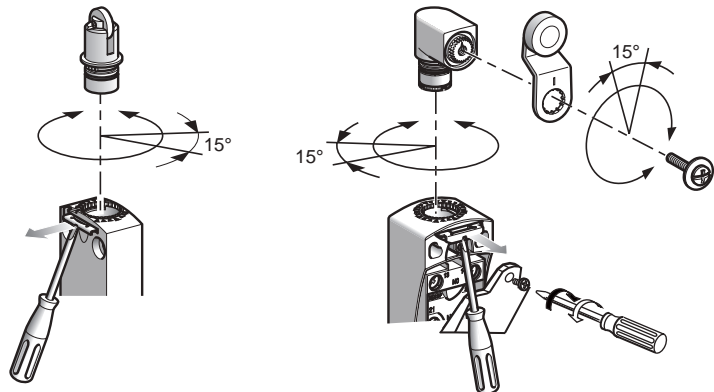

All the heads can be adjusted in 15° steps throughout 360°, in relation to the body.

All the levers can be adjusted in 15° steps throughout 360°, in relation to the horizontal axis of the head.

Limit switches

XC range

Variable composition: simplicity through innovation

Principle (continued)

Cable entries

- The cable entries for Compact design XCKD and XCKP switches enable:
 - simple cabling due to unrestricted access to contacts,

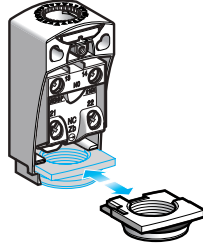

- simple adaptation to the various worldwide markets:
 - 6 models are available:



- ISO M16 x 1.5
- Pg 11

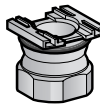

- ISO M20 x 1.5
- Pg 13.5
- 1/2" NPT
- PF 1/2 (G 1/2)

Each model is available in metal or plastic, respectively suited to Compact design XCKD and XCKP.

Connection components

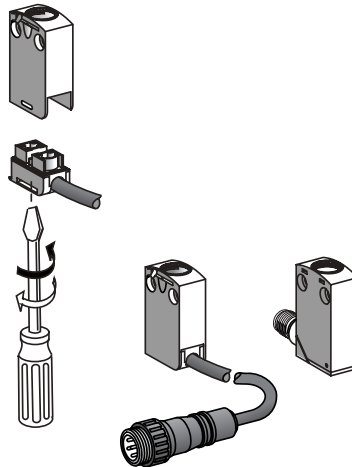

- The miniature XCMD range allows interchanging of these pre-cabled connection components:
 - a 1/4 of a turn is all that is required for removing the connection component on XCMD bodies with 2 and 3 contacts,
 - 6 alternative cable lengths are available as standard.

- The miniature XCMD range also includes an integral or remote connector solution.

Contact block or bodies with contact

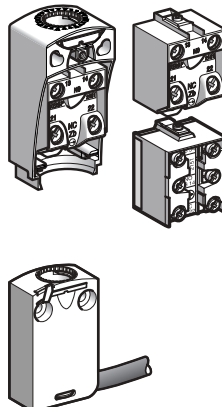

- 2 and 3 snap action and slow break contact blocks, with positive opening operation, are interchangeable between the Compact design XCKD and XCKP and Classic XCKJ, XCKS, XCKM and XCKL ranges.

- For the miniature design XCMD range, the contacts are an integral part of the body:
 - 2 and 3 snap action and slow break contacts, with positive opening operation, and interchangeable connection component,
 - 4 snap action contacts, with positive opening operation, with monolithic body and connection components.

Presentation

Electromechanical detection

Limit switches are used in all automated installations and also in a wide variety of applications, due to the numerous advantages inherent to their technology. They transmit data to the logic processing system regarding:

- presence/absence,
- passing,
- positioning,
- end of travel.

Simplicity of installation, advantages

■ From an electrical viewpoint

- galvanic separation of circuits,
- models suitable for low power switching combined with good electrical durability,
- very good short-circuit withstand in coordination with appropriate fuses,
- total immunity to electromagnetic interference,
- high rated operational voltage.

■ From a mechanical viewpoint

- NC contacts with positive opening operation,
- high resistance to the different ambient conditions encountered in industry (standard tests and specific tests under laboratory conditions),
- high repeat accuracy, up to 0.01 mm on the tripping points.

Detection movements

- Linear movement (plunger)
- Rotary movement (lever)
- Multi-directional movement

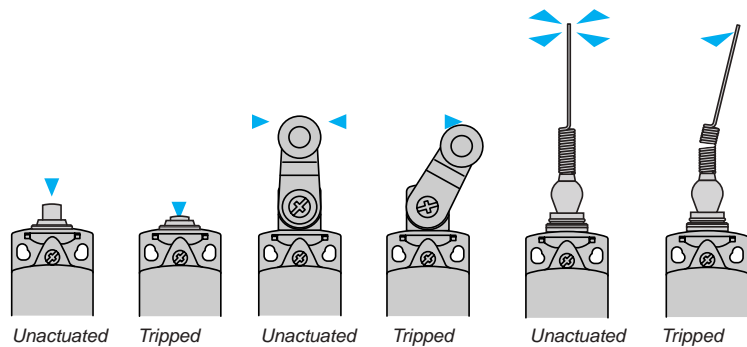

Terminology

Rated value of a quantity	<ul style="list-style-type: none"> ■ This replaces the term “nominal value”. ■ It is the fixed value for a specific function.
Utilisation categories:	<ul style="list-style-type: none"> ■ AC-15 replaces AC-11: control of an electromagnet on AC, test 10 Ie/Ie. ■ AC-12: control of a resistive load on AC or static load isolated by opto-coupler. ■ DC-13 replaces DC-11: control of an electromagnet on DC, test Ie/Ie.
Positive opening travel	■ Minimum travel from the initial movement of contact actuator to the position required to accomplish positive opening operation.
Positive opening force	■ The force required on the contact actuator to accomplish positive opening operation.
Switching capacity	<ul style="list-style-type: none"> ■ I_{th} is no longer a rated value but a conventional current used for heating tests. Example: for category A300 the corresponding operational current, I_e maximum, is 6 A-120 V or 3 A-240 V, the equivalent I_{th} being 10 A.
Positive opening operation	<ul style="list-style-type: none"> ■ A limit switch complies to this specification when all the closed contact elements of the switch can be changed, with certainty, to the open position (no flexible link between the moving contacts and the operator of the switch, to which an actuating force is applied). ■ All limit switches incorporating either a slow break contact block or a snap action NC + NO (form Zb), NC + NO + NO, NC + NC + NO, NC + NC + NO + NO contact block are positive opening operation, in complete conformity with standard IEC 60947-5-1 Appendix K.

Contact blocks

Snap action contacts

- Snap action contacts are characterised by different tripping and reset points (differential travel).
- The displacement speed of the moving contacts is not related to the speed of the operator.
- This feature ensures satisfactory electrical performance in applications involving low speed actuators.

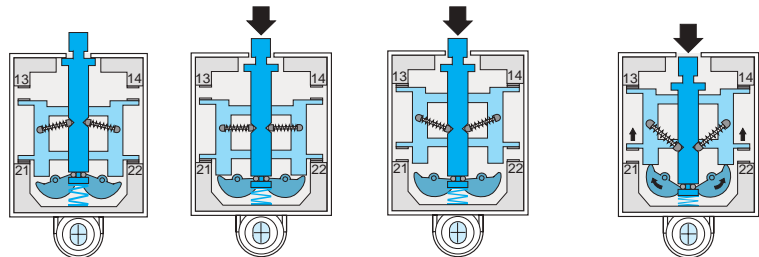

Unactuated state Approach travel Contact change of state Positive opening

Slow break contacts

- Slow break contacts are characterised by identical tripping and resetting points.
 - The displacement speed of the moving contacts is equal, or proportional, to the speed of the operator (which must not be less than 0.1 m/s = 6 m/minute).
- The opening distance is also dependent on the distance travelled by the operator.

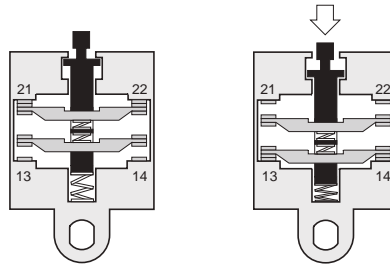

Electrical durability for normal loads

- Normally, for inductive loads, the current value is less than 0.1 A (sealed), i.e. values of 3 to 40 VA sealed and 30 to 1000 VA inrush, depending on the voltage.

For this type of application the electrical durability will exceed 10 million operating cycles.

Application example: XCKJ161 + LC1D12●●● (7 VA sealed, 70 VA inrush).
Electrical durability = 10 million operating cycles.

Switching capacity

- 1 Normal industrial PLC input type 1 (PLC: industrial programmable logic controllers)
- 2 Normal industrial PLC input type 2

3 Switching capacity conforming to IEC 60947-5-5, utilisation category AC-15, DC-13

A300	240 V	3 A	B300	240 V	1.5 A
Q300	250 V	0.27 A	R300	250 V	0.13 A

4 Switching capacity conforming to IEC 60947-5-1, utilisation category AC-15, DC-13

A300	120 V	6 A	B300	120 V	3 A
Q300	125 V	0.55 A	R300	125 V	0.27 A

Electrical durability for small loads

- The use of limit switches with programmable controllers is becoming more common.
- With small loads, limit switches offer the following levels of reliability:
 - failure rate of less than 1 for 100 million operating cycles using snap action contacts (contacts XE2SP),
 - failure rate of less than 1 for 20 million operating cycles using slow break contacts (contacts XE●NP and XE3SP).
 - failure rate of less than 1 for 5 million operating cycles using contacts XCMD.

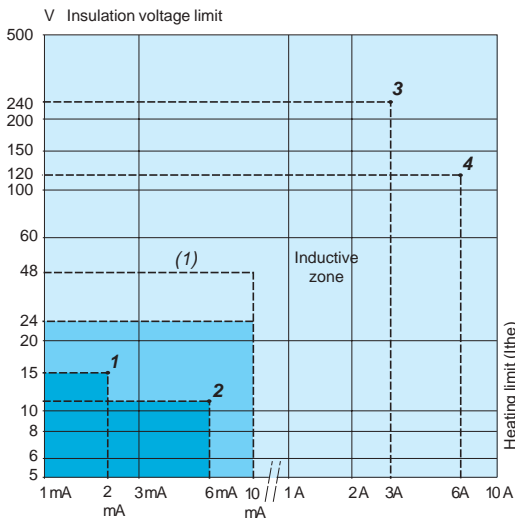

		Range of use	
Standard contacts	XE2SP2151, P3151		
	XE2NP●●●●		
Continuous service (frequent switching)	Contacts of XCMD		
	XE3●P●●●●		
Gold flashed contacts on resistive load	Occasional service Infrequent switching, ≤ 1 operating cycle/ day, and/or corrosive atmosphere		(1)

(1) Usable up to 48 V/10 mA.

Contact blocks (continued)

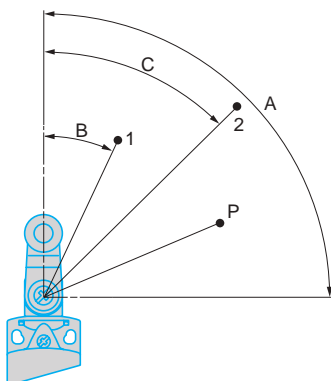
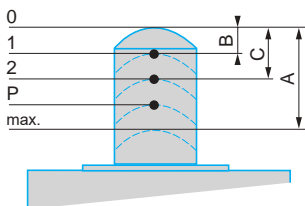
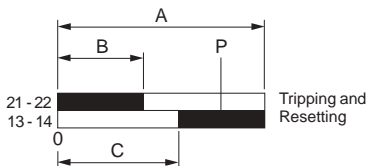
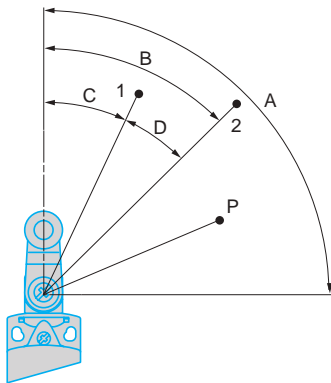
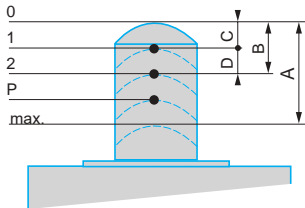
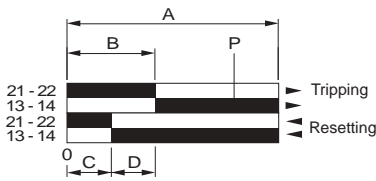

Functional diagrams of snap action contacts

■ Example: NC + NO

- A - Maximum travel of operator in millimetres or degrees.
- B - Tripping travel of contact.
- C - Resetting travel of contact.
- D - Differential travel = B - C.
- P - Point from which positive opening is assured.

□ Linear movement (plunger)

- 1 - Resetting point of contact.
- 2 - Tripping point of contact.
- A - Maximum travel of operator in millimetres.
- B - Tripping travel of contact.
- C - Resetting travel of contact.
- D - Differential travel = B - C.
- P - Point from which positive opening is assured.

□ Rotary movement (lever)

- 1 - Resetting point of contact.
- 2 - Tripping point of contact.
- A - Maximum travel of operator in degrees.
- B - Tripping travel of contact.
- C - Resetting travel of contact.
- D - Differential travel = B - C.
- P - Point from which positive opening is assured.

Functional diagrams of slow break contacts

■ Example: NC + NO break before make

- A - Maximum travel of operator in millimetres or degrees.
- B - Tripping and resetting travel of contact 21-22.
- C - Tripping and resetting travel of contact 13-14.
- P - Point from which positive opening is assured.

□ Linear movement (plunger)

- 1 - Tripping and resetting points of contact 21-22.
- 2 - Tripping and resetting points of contact 13-14.
- A - Maximum travel of operator in millimetres.
- B - Tripping and resetting travel of contact 21-22.
- C - Tripping and resetting travel of contact 13-14.
- P - Positive opening point.

□ Rotary movement (lever)

- 1 - Tripping and resetting points of contact 21-22.
- 2 - Tripping and resetting points of contact 13-14.
- A - Maximum travel of operator in degrees.
- B - Tripping and resetting travel of contact 21-22.
- C - Tripping and resetting travel of contact 13-14.
- P - Positive opening point.

Contact blocks (continued)

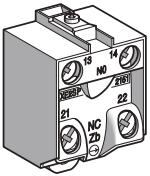

XE2•P screw clamp terminal connections

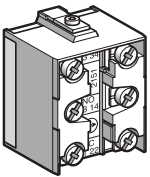

XE3•P screw clamp terminal connections

Mounting

Contact connections

- Tightening torque:
 - minimum tightening torque ensuring the nominal characteristics of the contact: 0.8 N.m,
 - maximum tightening torque without damage to the terminals: 1.2 N.m for XE2•P, 1 N.m for XE3•P.
- Connecting cable: cable preparation lengths:
 - for XE2•P, L = 22 mm,
 - for XE2•P3•••, L = 45 mm,

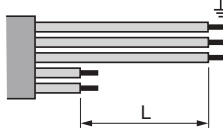

- for XE3•P, L = 14 mm, L1 = 11 mm.

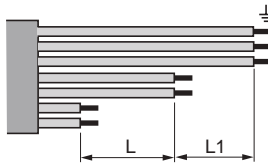

Sweep of connecting cable

- 1 Recommended
- 2 To be avoided

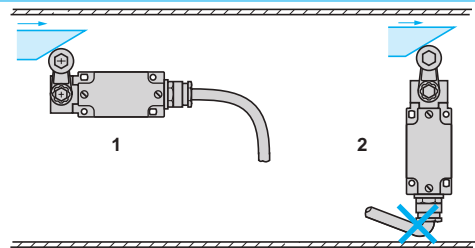

Position of cable gland

- 1 Recommended
- 2 To be avoided

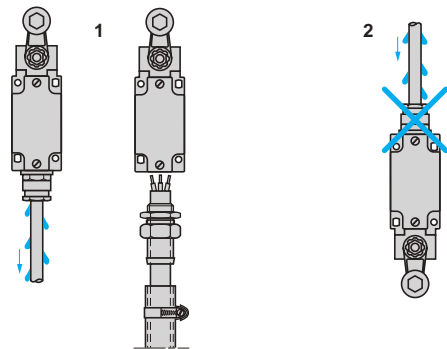

Type of cam

- 1 Recommended
- 2 To be avoided

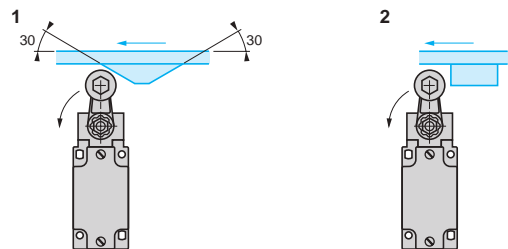

Mounting and fixing limit switches by the head

- 1 Recommended
- 2 Forbidden

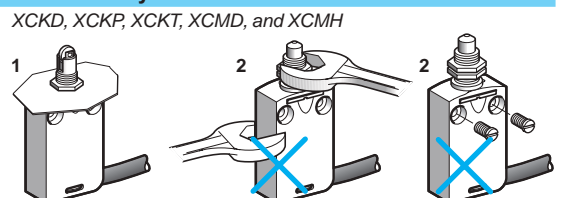

XCKD, XCKP, XCKT, XCMD, and XCMH

Setting-up

Tightening torque

- The minimum torque is that required to ensure correct operation of the switch.
- The maximum torque is the value which, if exceeded, will damage the switch.

Range	Item	Torque (N.m)		Torque (lb-in)	
		Min.	Max.	Min.	Max.
Compact design XCKD, XCKP, XCKT	Cover	0.8	1.2	7.08	10.62
	Fixing screw for lever on rotary head	1	1.5	8.85	13.27
Miniature design XCMD, XCMH, XCMV	Fixing screw for the product	1	1.5	8.85	13.27
	Fixing screw for lever on rotary head	1	1.5	8.85	13.27
Compact design XCKN	Cover	0.8	1.2	7.08	10.62
	Fixing screw for lever on rotary head	1	1.5	8.85	13.27
Classic design XCKJ	Cover	1	1.5	8.85	13.27
	Fixing nut for lever on rotary head	1	1.5	8.85	13.27
Classic design XCKS	Cover	0.8	1.2	7.08	10.62
	Fixing nut for lever on rotary head ZCKD	1	1.5	8.85	13.27
	Fixing nut for lever on rotary head XCKS	0.8	1.2	7.08	10.62
	Fixing head on body	0.8	1.2	7.08	10.62
Classic design XCKM, XCKML, XCKL	Cover	0.8	1.2	7.08	10.62
	Fixing nut for lever on rotary head	1	1.5	8.85	13.27

XCMH

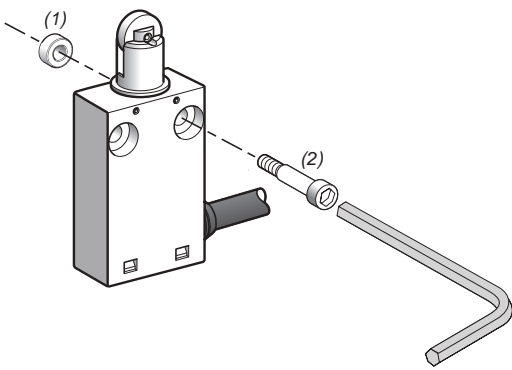

(1) 2 spacers supplied with the switch.
(2) 2 screws Ø 4mm (not included).

XCKD, XCKP, XCKT, XCMD, XCMV

- Adjustable in 3 planes:

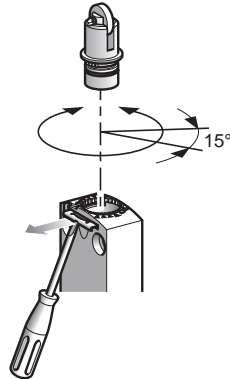

All the heads can be adjusted in 15° steps throughout 360°, in relation to the body.

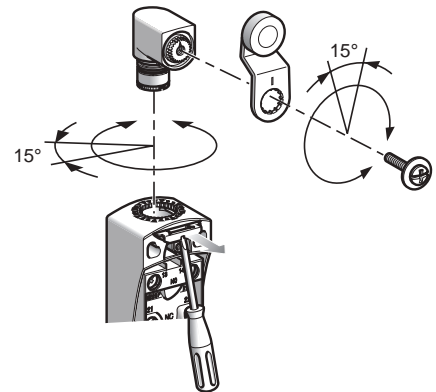

All the levers can be adjusted in 15° steps throughout 360°, in relation to the horizontal axis of the head.

XCKJ

- Adjustable throughout 360° in 5° steps, or in 45° steps by reversing the lever or its mounting.

- 1 Reversed $\alpha = 5^\circ$
- 2 Forward $\alpha = 45^\circ$

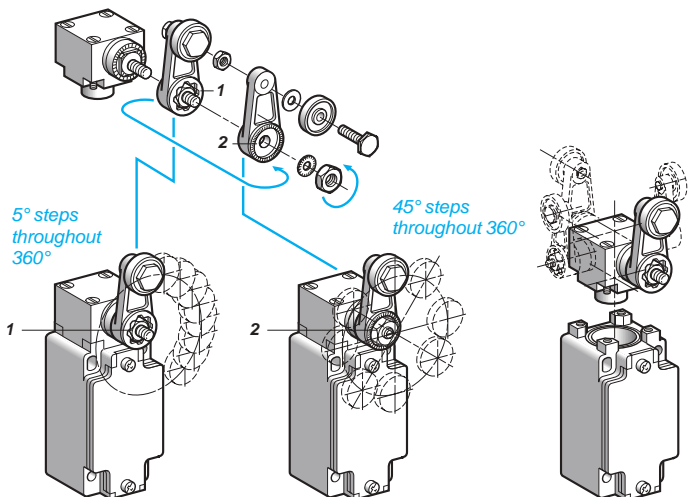

Setting-up (continued)

Direction of actuation programming

■ XC2J

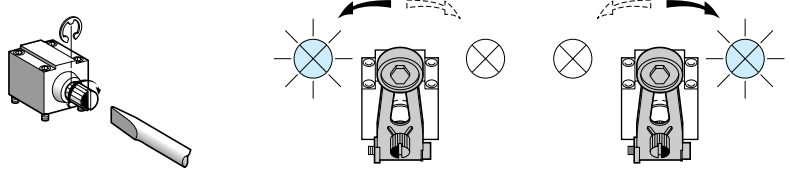

Head ZC2JE05

■ XCKJ

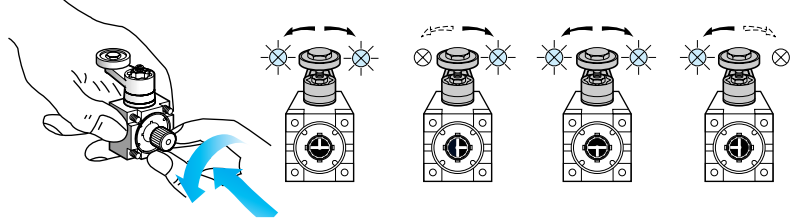

Head ZCKE05

■ XCKS

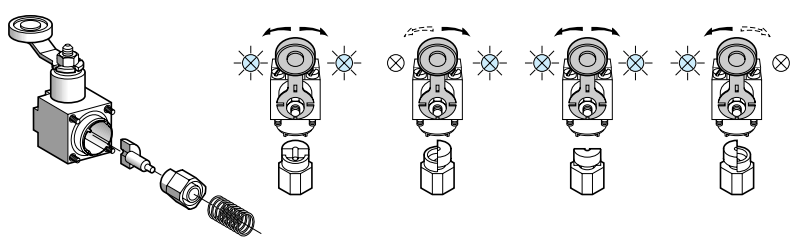

Head ZCKD05

■ XCKD, XCKP, XCKT and XCMD

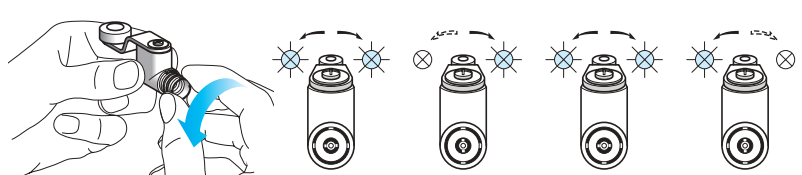

Head ZCE05

Specific cams for heads ZCKE09 and ZC2JE09

- 1 0.5 mm min.
- 2 2 mm min.

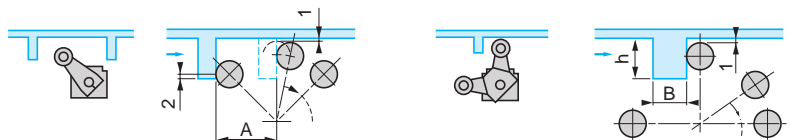

A = length of lever + 11 mm
ZCKE09: 13 < h < 18 mm and B = 12 mm max.
ZC2JE09: 14 < h < 24 mm and B = 6 mm max.

Reminder of the standards

The majority of Telemecanique Sensors products comply to national standards (for example French NF C standards, German DIN standards), European standards (for example CENELEC) or international standards (for example IEC). These standards rigidly stipulate the characteristic requirements of the designated products (for example IEC 60947 relating to low voltage switchgear and control gear). These products, when correctly used, enable the production of control equipment assemblies, machine control equipment or installations conforming to their own specific standards (for example IEC 60204 for the electrical equipment of industrial machines).

IEC 60947-5-1

Insulation coordination (and dielectric strength)

- The standard IEC 60664 defines 4 categories of prospective transient overvoltages. It is important for the user to select control circuit components which are able to withstand these overvoltages. To these ends, the manufacturer states the rated impulse withstand voltage (U imp) applicable to the product.

Terminal connections

- The cabling capacity, mechanical robustness and durability of the terminals, as well as the ability to resist loosening, are verified by standardised tests.
- Terminal reference marking conforms to standard IEC 60947-5-1 Appendix M.

Switching capacity

- With maximum electrical load. A single designation (A300 for example) enables indication of the contact block characteristics related to its utilisation category.

Positive opening operation (IEC 60947-5-1 Appendix K)

- For contacts used in safety applications (end of travel, emergency stop device, etc.) the assurance of positive opening is required (see IEC 60204, EN 60204) after each test, the opening of the contact being verified by testing with an impulse voltage (2500 V).

Electrical symbols for contacts



- Form Za, the 2 contacts (NO + NC) are the same polarity.



- Form Zb, the 2 contacts (NO + NC) are electrically separate.

Symbol for positive opening



- Simplified version



- Complete symbol

CENELEC EN 50047

The European standards organisation CENELEC, which has 14 member countries, has defined in this standard the first type of limit switch.

It defines 4 variants of devices (forms A, B, C, E). Limit switches XCKP, XCKD and XCKT conform to standard EN 50047.

(1) Minimum value
(2) Maximum value

A: reference axis
H: differential travel
P: tripping point
E: cable entry

Form A, with roller lever

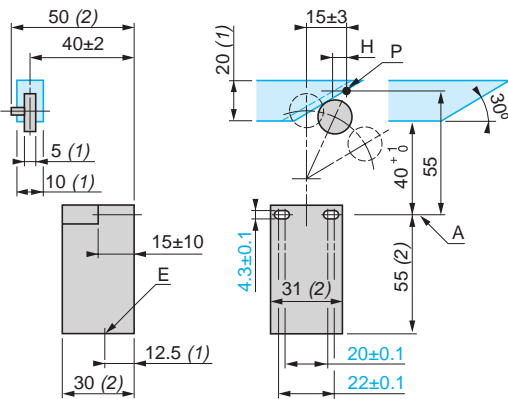

Form B, with end plunger (rounded)

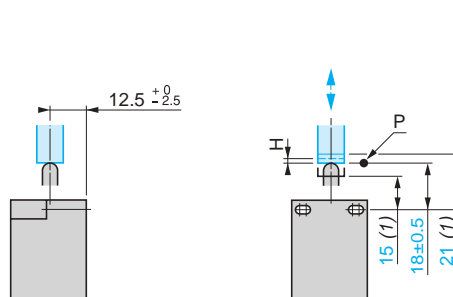

Form C, with end roller plunger

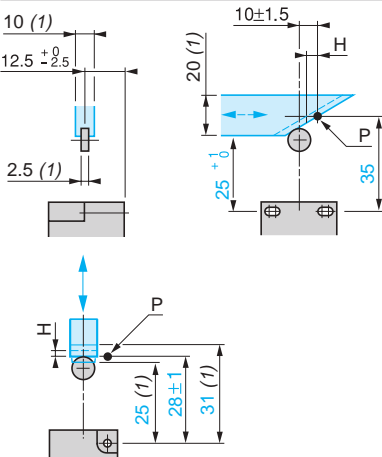

Form E, with roller lever for 1 direction of actuation

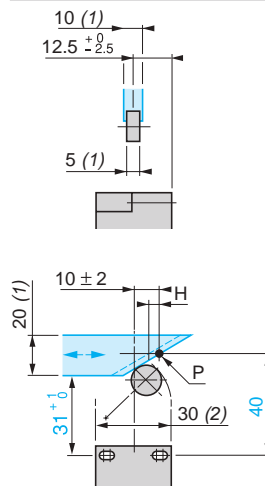

Reminder of the standards (continued)

CENELEC EN 50041

The European standards organisation CENELEC, which has 14 member countries, has defined in this standard the second type of limit switch.

It defines 6 variants of devices (forms A, B, C, D, F, G).
Limit switches XCKJ and XCKS conform to standard EN 50041.

(1) Minimum value
(2) Maximum value

A: reference axis
B: optional elongated holes
H: differential travel
P: tripping point
E: cable entry

Za: tripping zone
Sa: tripping threshold

Form A, with roller lever

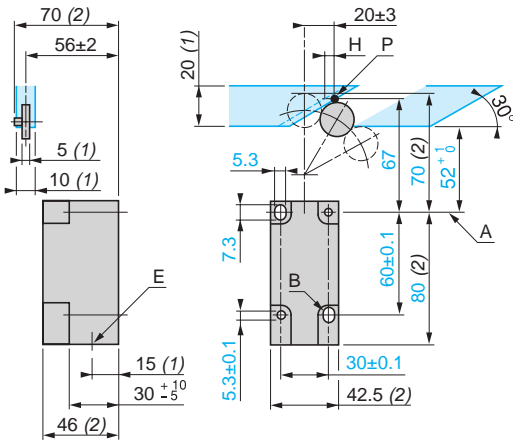

Form B, with end plunger (rounded)

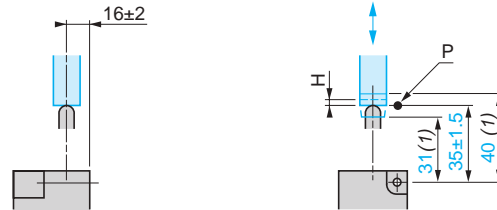

Form C, with end roller plunger

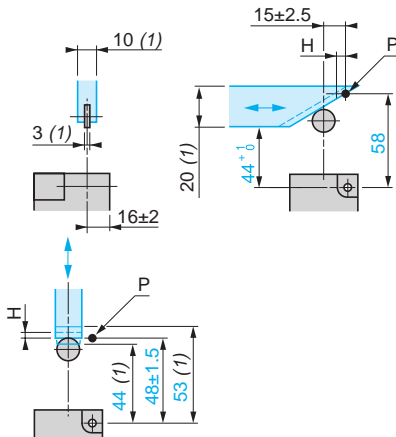

Form D, with rod lever

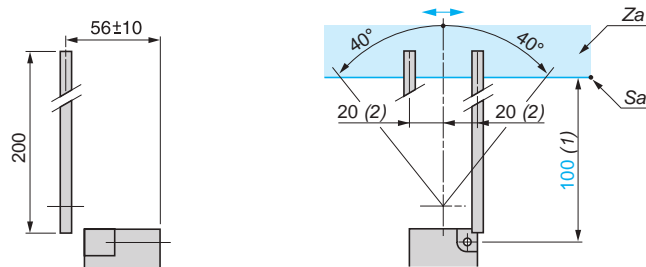

Form F, with side plunger (rounded)

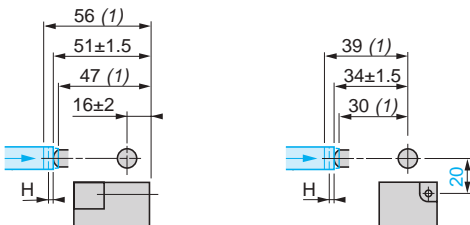

Form G, with side roller plunger

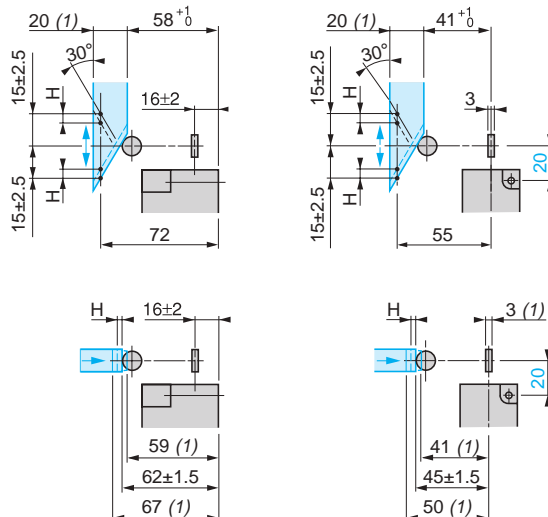

Limit switches

XC Standard range

Miniature design, metal, XCMD

■ XCMD
pre-cabled

□ With head for linear movement (plunger). Fixing by the body

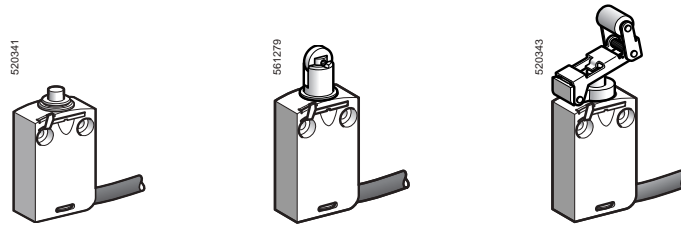

Complete switches: page 28. Variable composition: page 30

□ With head for linear movement (plunger). Fixing by the head

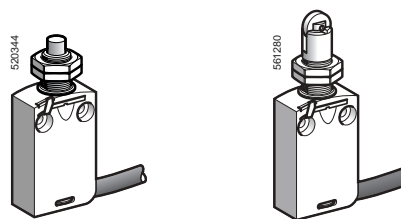

Complete switches: page 28. Variable composition: page 30

□ With head for rotary movement (lever) or multi-directional. Fixing by the body

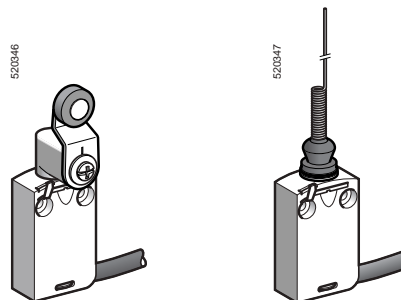

Complete switches: page 29. Variable composition: page 31

■ XCMD
with connector

□ With head for linear movement (plunger)
Fixing by the body

Fixing by the head

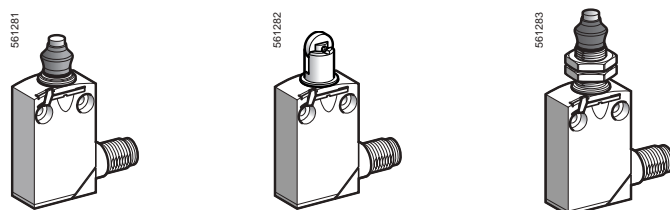

Complete switches: page 36. Variable composition: page 38

□ With head for rotary movement (lever) or multi-directional. Fixing by the body

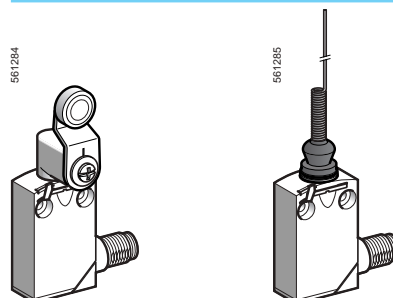

Complete switches: page 37. Variable composition: page 39

Environment characteristics

Conformity to standards	Products	CE, IEC 60947-5-1, EN 60947-5-1, UL 508, CSA C22-2 n° 14, EAC
	Machine assemblies	IEC 60204-1, EN 60204-1
Product certifications		UL, CSA (except products with special cables), CCC
Protective treatment		Standard version: "TC"
Ambient air temperature	For operation	- 25...+ 70°C (- 40...+ 70 °C with ZCE106, ZCE026 and ZCE016 heads)
	For storage	- 40...+ 70°C
Vibration resistance		XCMD snap action: 5 gn. XCMD slow break: 25 gn (10...500 Hz) conforming to IEC 60068-2-6
Shock resistance		25 gn (18 ms) conforming to IEC 60068-2-27 except head ZCE08: 15 gn (18 ms)
Electric shock protection		Class I conforming to IEC 61140 and NF C 20-030
Degree of protection		IP 66, IP 67 and IP 68 (1) conforming to IEC 60529; IK 06 conforming to IEC 62262
Materials		Bodies: Zamak, heads: Zamak
Repeat accuracy		0.05 mm on the tripping points, with 1 million operations for head with end plunger

(1) Protection against prolonged immersion: the test conditions are subject to agreement between the manufacturer and the user.

Contact block characteristics

Rated operational characteristics	Switches with 2 contacts	~ AC-15; B300 (Ue = 240 V, Ie = 1.5 A) --- DC-13; R300 (Ue = 250 V, Ie = 0.1 A), conforming to IEC 60947-5-1 Appendix A, EN 60947-5-1
	Switches with 3 and 4 contacts	~ AC-15; C300 (Ue = 240 V, Ie = 0.75 A) --- DC-13; R300 (Ue = 250 V, Ie = 0.1 A), conforming to IEC 60947-5-1 Appendix A, EN 60947-5-1
	Pre-cabled switches	Ithe = 6 A for 2 contacts, 4 A for 3 contacts, 3 A for 4 contacts
	Switches with M12, 4-pin connector	Ui = 250 V, Ie = 3 A maximum, Ithe = 3 A
	Switches with M12, 5-pin connector	Ui = 60 V, Ie = 4 A maximum, Ithe = 4 A
	Switches with 7/8"-16UN, 5-pin connector	Ui = 250 V, Ie = 6 A maximum, Ithe = 6 A
Rated insulation voltage		Ui = 400 V degree of pollution 3 conforming to IEC 60947-5-1 Ui = 300 V conforming to UL 508, CSA C22-2 n° 14
Rated impulse withstand voltage		U imp = 4 kV conforming to IEC 60947-1, IEC 60664
Positive operation (depending on model)		NC contacts with positive opening operation conforming to IEC 60947-5-1 Appendix K, EN 60947-5-1
Resistance across terminals		≤ 25 mΩ conforming to IEC 60255-7 category 3
Short-circuit protection		6 A cartridge fuse type gG (gl)
Minimum actuation speed (for head with end plunger)		Snap action contact: 0.01 m/minute, slow break contact: 6 m/minute
Electrical durability		<ul style="list-style-type: none"> ■ Conforming to IEC 60947-5-1 Appendix C ■ Utilisation categories AC-15 and DC-13 ■ Maximum operating rate: 3600 operating cycles/hour ■ Load factor: 0.5

AC supply
50/60 Hz ~
mm inductive circuit

XCMD snap action (NC + NO, NC + NC, NC + NC + NO, NC + NC + NO + NO contacts)

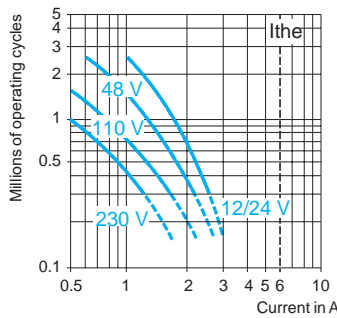

XCMD slow break (NC + NO, NC + NC + NO contacts)

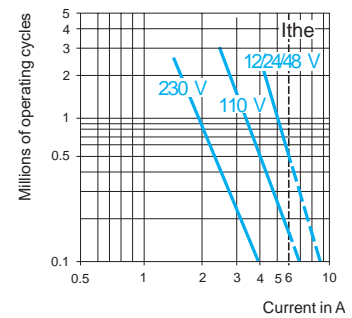

DC supply ---

Power broken in W for 5 million operating cycles				
Voltage	V	24	48	120
mm	W	3	2	1

Power broken in W for 5 million operating cycles				
Voltage	V	24	48	120
mm	W	4	3	3

Limit switches

XC Standard range
Miniature design, metal, XCMD
Complete units
Pre-cabled

Type of head	Plunger (fixing by the body)				Plunger (fixing by the head)		
--------------	------------------------------	--	--	--	------------------------------	--	--

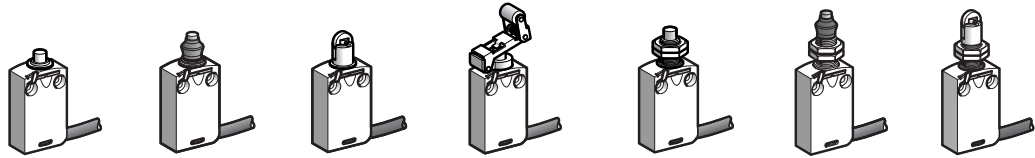

Type of operator	Metal end plunger	Metal end plunger with elastomer boot (1)	Steel roller plunger	Retractable steel roller lever plunger	M12 with metal end plunger	M16 with metal end plunger with elastomer boot (1)	M12 with steel roller plunger
------------------	-------------------	---	----------------------	--	----------------------------	--	-------------------------------

References

2-pole NC + NO snap action 	XCMD2110L1 	XCMD2111L1 	XCMD2102L1 	XCMD2124L1 	XCMD21F0L1 	XCMD21G1L1 	XCMD21F2L1
	2-pole NC + NO break before make, slow break 	XCMD2510L1 	XCMD2511L1 	XCMD2502L1 	—	XCMD25F0L1 	XCMD25G1L1
Weight (kg)	0.180	0.180	0.185	—	0.195	0.220	0.205
Contact operation			(A) = cam displacement (P) = positive opening point				

Complementary characteristics not shown under general characteristics (see page 27)

Switch actuation	On end	By 30° cam		On end	By 30° cam	
Type of actuation						
Maximum actuation speed	0.5 m/s				0.1 m/s	
Mechanical durability	10 million operating cycles					
Minimum force or torque	For tripping	8.5 N	7 N	2.5 N	8.5 N	7 N
	For positive opening	42.5 N	35 N	12.5 N	42.5 N	35 N
Cabling	PvR cable, 5 x 0.75 mm ² , length 1 m					

(1) Nitrile for indoor use

Limit switches

XC Standard range
Miniature design, metal, XCMD
Complete units
Pre-cabled

Type of head	Rotary (fixing by the body)				Multi-directional

Type of operator	Thermoplastic roller lever	Steel roller lever	Roller lever with ball bearing mounted roller	Variable length thermoplastic roller lever	"Cat's whisker" (1)
------------------	----------------------------	--------------------	---	--	---------------------

References	2-pole NC + NO snap action				
	XCMD2115L1 	XCMD2116L1 	XCMD2117L1 	XCMD2145L1 	XCMD2106L1
2-pole NC + NO break before make, slow break	XCMD2515L1 	XCMD2516L1 	XCMD2517L1 	XCMD2545L1 	XCMD2506L1
Weight (kg)	0.220	0.225	0.220	0.230	0.180
Contact operation			(A) = cam displacement (P) = positive opening point		

Complementary characteristics not shown under general characteristics (see page 27)		
Switch actuation	By 30° cam	
Type of actuation		
Maximum actuation speed	1.5 m/s	1 m/s
Mechanical durability	10 million operating cycles	5
Minimum force or torque	For tripping: 0.1 N.m	
	For positive opening: 0.5 N.m	–
Cablings	PvR cable, 5 x 0.75 mm ² , length 1 m	

(1) Value taken with actuation by moving part at 100 mm from the fixing.

Limit switches

XC Standard range
Miniature design, metal, XCMD
Modular units
Pre-cabled

Type of head	Plunger (fixing by the body)				Plunger (fixing by the head)		

Type of operator	Metal end plunger	Metal end plunger with elastomer boot (1)	Steel roller plunger	Retractable steel roller lever plunger	M12 with metal end plunger	M16 with metal end plunger with elastomer boot (1)	M12 with steel roller plunger
------------------	-------------------	---	----------------------	--	----------------------------	--	-------------------------------

References (combined with removable terminal block)

2-pole NC + NC snap action 	ZCMD29L1 + ZCE10 	ZCMD29L1 + ZCE11 	ZCMD29L1 + ZCE02 	ZCMD29L1 + ZCE24 	ZCMD29L1 + ZCEF0 	ZCMD29L1 + ZCEG1 	ZCMD29L1 + ZCEF2
3-pole NC + NC + NO snap action 	ZCMD39L1 + ZCE10 	ZCMD39L1 + ZCE11 	ZCMD39L1 + ZCE02 	ZCMD39L1 + ZCE24 	ZCMD39L1 + ZCEF0 	ZCMD39L1 + ZCEG1 	ZCMD39L1 + ZCEF2
3-pole NC + NC + NO break before make, slow break 	ZCMD29L1 + ZCE10 	ZCMD37L1 + ZCE11 	ZCMD37L1 + ZCE02 	ZCMD37L1 + ZCE24 	ZCMD37L1 + ZCEF0 	ZCMD37L1 + ZCEG1 	ZCMD37L1 + ZCEF2
Weight (kg)	0.180	0.180	0.185	0.200	0.195	0.220	0.205
4-pole 2 NC + 2 NO snap action 	ZCMD4DL1 + ZCE10 	ZCMD4DL1 + ZCE11 	ZCMD4DL1 + ZCE02 	ZCMD4DL1 + ZCE24 	ZCMD4DL1 + ZCEF0 	ZCMD4DL1 + ZCEG1 	ZCMD4DL1 + ZCEF2
Weight (kg)	0.160	0.160	0.165	0.180	0.175	0.200	0.185

References (combined with fixed terminal block)

4-pole 2 NC + 2 NO snap action 	ZCMD41L1 + ZCE10 	ZCMD41L1 + ZCE11 	ZCMD41L1 + ZCE02 	ZCMD41L1 + ZCE24 	ZCMD41L1 + ZCEF0 	ZCMD41L1 + ZCEG1 	ZCMD41L1 + ZCEF2
Weight (kg)	0.160	0.160	0.165	0.180	0.175	0.200	0.185
Contact operation	closed open		(A) = cam displacement (P) = positive opening point		NC contact with positive opening operation		

Complementary characteristics not shown under general characteristics (see page 27)

Switch actuation	On end	By 30° cam		On end	By 30° cam
Type of actuation					
Maximum actuation speed	0.5 m/s				0.1m/s
Mechanical durability	10 million operating cycles				
Minimum force or torque	For tripping	8.5 N	7 N	2.5 N	8.5 N
	For positive opening	42.5 N	35 N	12.5 N	42.5 N
Cabling	PvR cable, 5 x 0.75 mm ² length 1 m for 2-pole contact versions, 7 x 0.5 mm ² length 1 m for 3-pole contact versions, 9 x 0.34 mm ² length 1 m for 4-pole contact versions. For other lengths, see page 48.				

(1) Nitrile for indoor use

Limit switches

XC Standard range
Miniature design, metal, XCMD
Modular units
Pre-cabled

Type of head	Rotary (fixing by the body)				Multi-directional
Type of operator	Thermoplastic roller lever	Steel roller lever	Roller lever with ball bearing mounted roller	Variable length thermoplastic roller lever	"Cat's whisker" (1)

References (combined with removable terminal block)					
2-pole NC + NC snap action 	ZCMD29L1 + ZCE01 + ZCY15 	ZCMD29L1 + ZCE01 + ZCY16 	ZCMD29L1 + ZCE01 + ZCY17 	ZCMD29L1 + ZCE01 + ZCY45 	ZCMD29L1 + ZCE06
3-pole NC + NC + NO snap action 	ZCMD39L1 + ZCE01 + ZCY15 	ZCMD39L1 + ZCE01 + ZCY16 	ZCMD39L1 + ZCE01 + ZCY17 	ZCMD39L1 + ZCE01 + ZCY45 	ZCMD39L1 + ZCE06
3-pole NC + NC + NO break before make, slow break 	ZCMD37L1 + ZCE01 + ZCY15 	ZCMD37L1 + ZCE01 + ZCY16 	ZCMD37L1 + ZCE01 + ZCY17 	ZCMD37L1 + ZCE01 + ZCY45 	ZCMD37L1 + ZCE06
Weight (kg)	0.220	0.225	0.220	0.230	0.180
4-pole 2 NC + 2 NO snap action 	ZCMD4DL1 + ZCE01 + ZCY15 	ZCMD4DL1 + ZCE01 + ZCY16 	ZCMD4DL1 + ZCE01 + ZCY17 	ZCMD4DL1 + ZCE01 + ZCY45 	ZCMD4DL1 + ZCE06
Weight (kg)	0.200	0.205	0.200	0.210	0.160
References (combined with fixed terminal block)					
4-pole 2 NC + 2 NO snap action 	ZCMD41L1 + ZCE01 + ZCY15 	ZCMD41L1 + ZCE01 + ZCY16 	ZCMD41L1 + ZCE01 + ZCY17 	ZCMD41L1 + ZCE01 + ZCY45 	ZCMD41L1 + ZCE06
Weight (kg)	0.200	0.205	0.200	0.210	0.160
Contact operation					
Complementary characteristics not shown under general characteristics (see page 27)					
Switch actuation	By 30° cam				By any moving part
Type of actuation					
Maximum actuation speed	1.5 m/s				1 m/s
Mechanical durability	10 million operating cycles				5
Minimum force or torque	For tripping	0.1 N.m			
	For positive opening	0.5 N.m			
Cabling	PvR cable, 5 x 0.75 mm ² length 1 m for 2-pole contact versions, 7 x 0.5 mm ² length 1 m for 3-pole contact versions, 9 x 0.34 mm ² length 1 m for 4-pole contact versions. For other lengths, see page 48.				

(1) Value taken with actuation by moving part at 100 mm from the fixing.

Limit switches

XC Standard range

Miniature design, metal, XCMD

Complete units

Pre-cabled

Dimensions

XCMD2•10L1

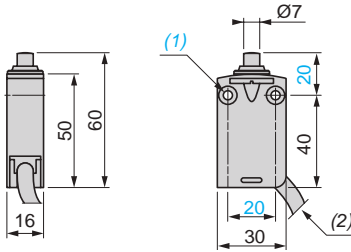

XCMD2•11L1

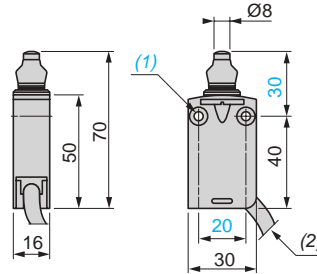

XCMD2•02L1

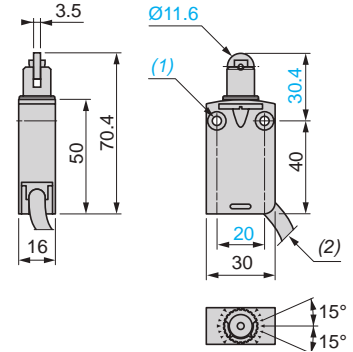

XCMD2•24L1

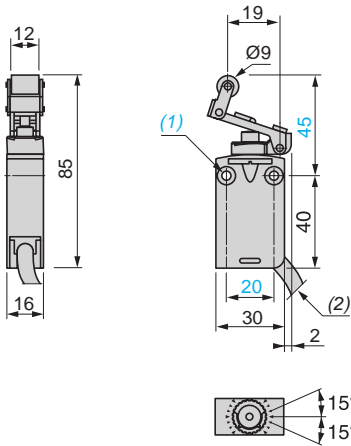

XCMD2•F0L1

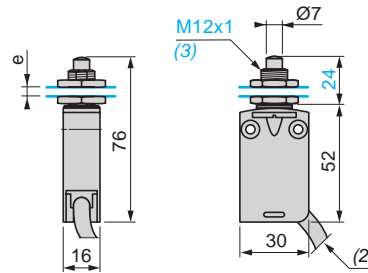

XCMD2•G1L1

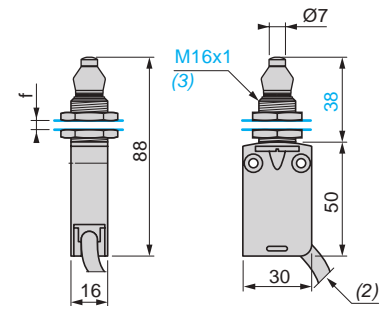

XCMD2•F2L1

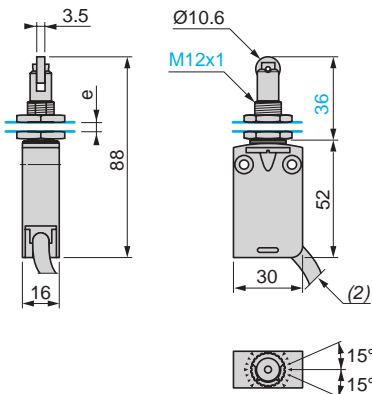

(1) 2 fixing holes \varnothing 4.2 mm, counterbored \varnothing 8 mm by 4 mm deep

(2) External diameter of cable 7.5 mm

(3) Fixing nut thickness 3.5 mm

e: 8 mm max, panel cut-out \varnothing 12.5 mm

f: 8 mm max, panel cut-out \varnothing 16.5 mm

Limit switches

XC Standard range
Miniature design, metal, XCMD
Complete units
Pre-cabled

Dimensions (continued)

XCMD2●15L1

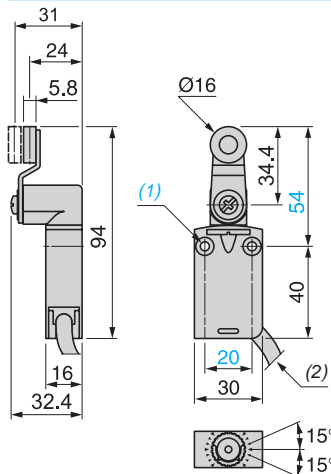

XCMD2●16L1

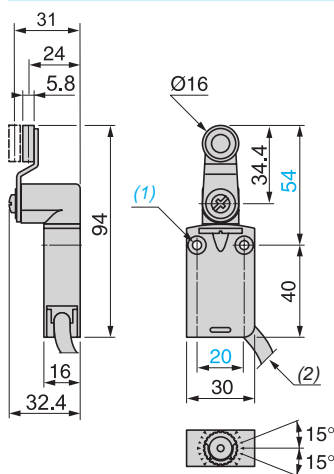

XCMD2●17L1

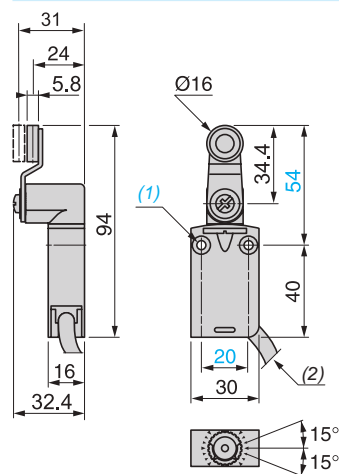

XCMD2●45L1

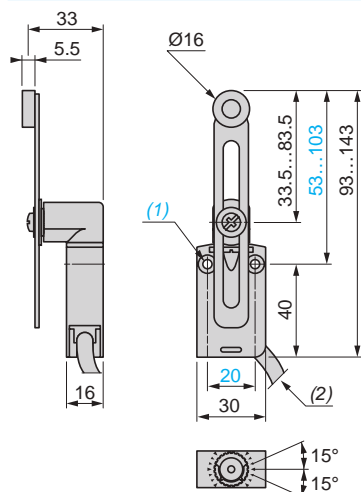

XCMD2●06L1

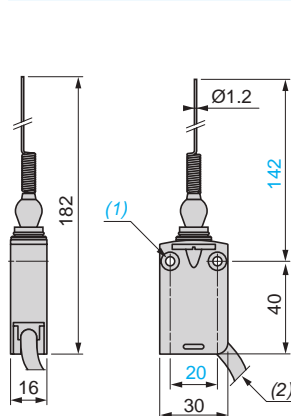

Mounting: distance required for connection

XCMD2●●●L1

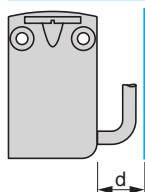

d: 20 mm min.

Note: For modular switches ZCMD4D, ZCMD4DL● and ZCMC4DL●: d: 35 mm min.

(1) 2 fixing holes Ø 4.2 mm, counterbored Ø 8 mm by 4 mm deep

(2) External diameter of cable 7.5 mm

e: 8 mm max, panel cut-out Ø 12.5 mm

f: 8 mm max, panel cut-out Ø 16.5 mm

Limit switches

XC Standard range

Miniature design, metal, XCMD

Modular units

Pre-cabled

Dimensions

ZCMD●●L1 + ZCE10,
ZCMD4DL1 + ZCE10,
ZCMD41L1 + ZCE10

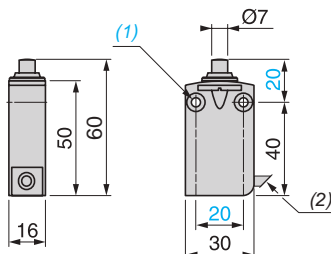

ZCMD●●L1 + ZCE11,
ZCMD4DL1 + ZCE11,
ZCMD41L1 + ZCE11

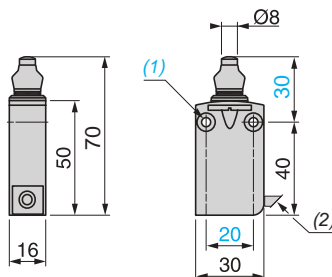

ZCMD●●L1 + ZCE02,
ZCMD4DL1 + ZCE02,
ZCMD41L1 + ZCE02

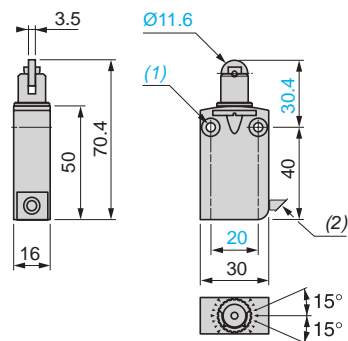

ZCMD●●L1 + ZCE24,
ZCMD4DL1 + ZCE24,
ZCMD41L1 + ZCE24

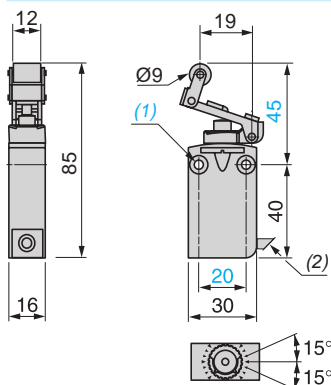

ZCMD●●L1 + ZCEF0,
ZCMD4DL1 + ZCEF0,
ZCMD41L1 + ZCEF0

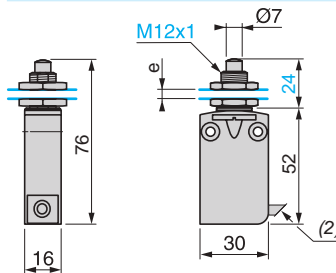

ZCMD●●L1 + ZCEG1,
ZCMD4DL1 + ZCEG1,
ZCMD41L1 + ZCEG1

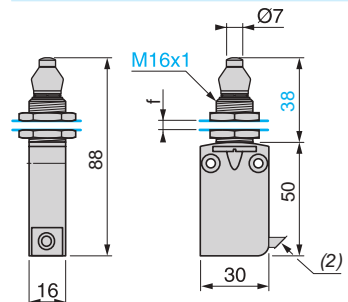

(1) 2 fixing holes Ø 4.2 mm, counterbored Ø 8 mm by 4 mm deep

(2) External diameter of cable 7.5 mm

e: 8 mm max, panel cut-out Ø 12.5 mm, fixing nut thickness 3.5 mm.

f: 8 mm max, panel cut-out Ø 16.5 mm, fixing nut thickness 3.5 mm.

Limit switches

XC Standard range

Miniature design, metal, XCMD

Modular units

Pre-cabled

Dimensions (continued)

ZCMD●●L1 + ZCEF2,
ZCMD4DL1 + ZCEF2,
ZCMD41L1 + ZCEF2

ZCMD●●L1 + ZCE01 + ZCY15/16/17,
ZCMD4DL1 + ZCE01 + ZCY15/16/17,
ZCMD41L1 + ZCE01 +
ZCY15/16/17

ZCMD●●L1 + ZCE01 + ZCY45,
ZCMD4DL1 + ZCE01 + ZCY45,
ZCMD41L1 + ZCE01 + ZCY45

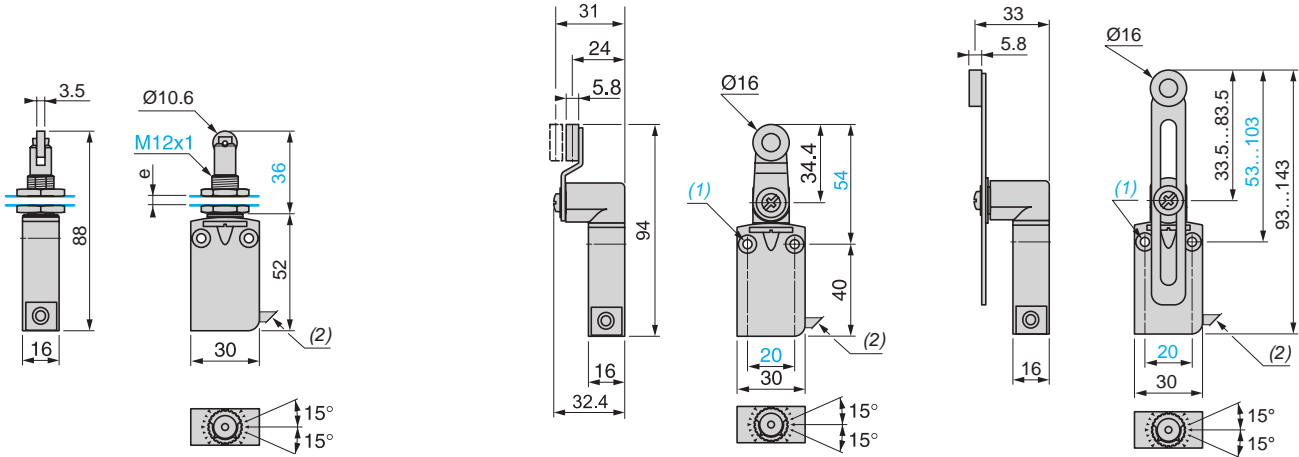

ZCMD●●L1 + ZCE06,
ZCMD4DL1 + ZCE06,
ZCMD41L1 + ZCE06

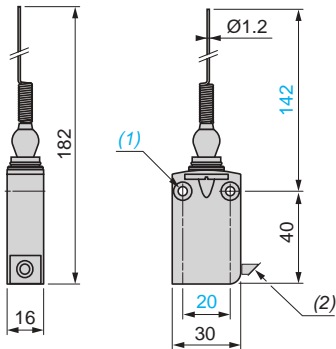

(1) 2 fixing holes Ø 4.2 mm, counterbored Ø 8 mm by 4 mm deep

(2) External diameter of cable 7.5 mm

e: 8 mm max, panel cut-out Ø 12.5 mm, fixing nut thickness 3.5 mm.

f: 8 mm max, panel cut-out Ø 16.5 mm, fixing nut thickness 3.5 mm.

Limit switches

XC Standard range
Miniature design, metal, XCMD
Complete units
Connector

Type of head	Plunger (fixing by the body)				Plunger (fixing by the head)		
--------------	------------------------------	--	--	--	------------------------------	--	--

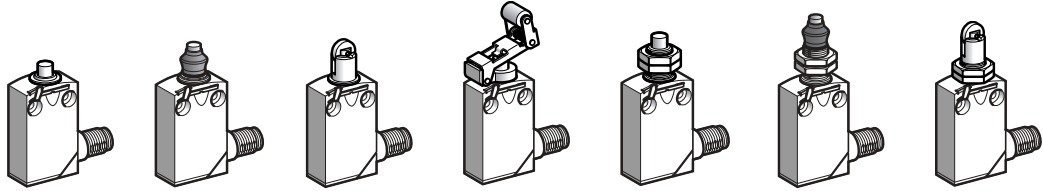

Type of operator	Metal end plunger	Metal end plunger with elastomer boot (1)	Steel roller plunger	Retractable steel roller lever plunger	M12 with metal end plunger	M16 with metal end plunger with elastomer boot (1)	M12 with steel roller plunger
------------------	-------------------	---	----------------------	--	----------------------------	--	-------------------------------

References

<p>Single-pole CO snap action + integral M12 4-pin connector</p>	<p>XCMD2110M12 1.8 4.2(P) 0.8 5mm</p>	<p>XCMD2111M12 1.8 4.2(P) 0.8 5mm</p>	<p>XCMD2102M12 3.1(A) 7(P) 1.4 mm</p>	<p>XCMD2124M12 11.2(A) 25(P) 4.9 mm</p>	<p>XCMD21F0M12 1.8 4.2(P) 0.8 5mm</p>	<p>XCMD21G1M12 1.8 4.2(P) 0.8 5mm</p>	<p>XCMD21F2M12 3.1(A) 7(P) 1.4 mm</p>
	<p>2-pole NC + NO snap action + integral M12 5-pin connector</p>	<p>XCMD2110C12 1.8 4.2(P) 0.8 5mm</p>	<p>XCMD2111C12 1.8 4.2(P) 0.8 5mm</p>	<p>XCMD2102C12 3.1(A) 7(P) 1.4 mm</p>	<p>XCMD2124C12 11.2(A) 25(P) 4.9 mm</p>	<p>XCMD21F0C12 1.8 4.2(P) 0.8 5mm</p>	<p>XCMD21G1C12 1.8 4.2(P) 0.8 5mm</p>
Weight (kg)	0.085	0.085	0.090	0.105	0.100	0.125	0.110
Contact operation	closed open		(A) = cam displacement (P) = positive opening point	NC contact with positive opening operation			

Complementary characteristics not shown under general characteristics (see page 27)







Switch actuation	On end	By 30° cam		On end	By 30° cam	
Type of actuation						
Maximum actuation speed	0.5 m/s				0.1 m/s	
Mechanical durability	10 million operating cycles					
Minimum force or torque	For tripping	8.5 N	7 N	2.5 N	8.5 N	7 N
	For positive opening	42.5 N	35 N	12.5 N	42.5 N	35 N
Positive operation	Although their design is identical to the pre-cabled switches, the switches incorporating an M12 4-pin connector cannot be marked with the ⊖ symbol because they are single-pole CO.					

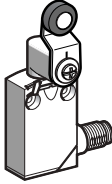
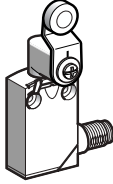
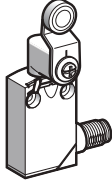
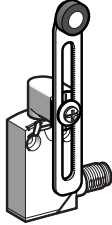
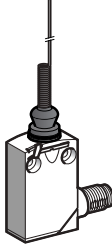

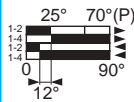
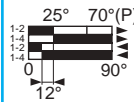
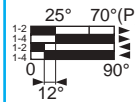
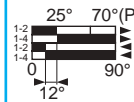
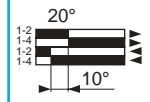
(1) Nitrile for indoor use.

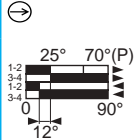
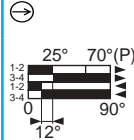
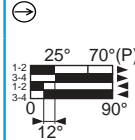
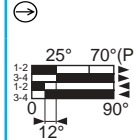
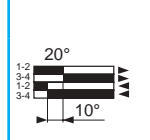
Limit switches

XC Standard range
Miniature design, metal, XCMD
Complete units
Connector

Type of head	Rotary (fixing by the body)				Multi-directional
					
Type of operator	Thermoplastic roller lever	Steel roller lever	Roller lever with ball bearing mounted roller	Variable length thermoplastic roller lever	"Cat's whisker" (1)

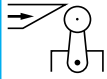
References	XCMD2115M12	XCMD2116M12	XCMD2117M12	XCMD2145M12	XCMD2106M12
 <p>Single-pole CO snap action With integral M12 4-pin connector</p>					
 <p>2-pole NC + NO snap action With integral M12 5-pin connector</p>					
Weight (kg)	0.125	0.130	0.125	0.135	0.085
Contact operation	 closed  open		(A) = cam displacement (P) = positive opening point	 NC contact with positive opening operation	

Complementary characteristics not shown under general characteristics (see page 27)		
Switch actuation	By 30° cam	By any moving part
Type of actuation		
Maximum actuation speed	1.5 m/s	1 m/s
Mechanical durability	10 million operating cycles	5
Minimum force or torque	For tripping	0.1 N.m
	For positive opening	0.5 N.m
Positive operation	Although their design is identical to the pre-cabled switches, the switches incorporating an M12 4-pin connector cannot be marked with the  symbol because they are single-pole CO.	

(1) Value taken with actuation by moving part at 100 mm from the fixing.

Limit switches

XC Standard range
Miniature design, metal, XCMD
Modular units
Connector

Type of head	Plunger (fixing by the body)				Plunger (fixing by the body)		
--------------	------------------------------	--	--	--	------------------------------	--	--

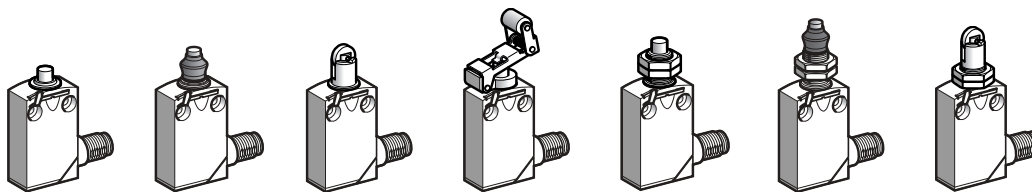

Type of operator	Metal end plunger	Metal end plunger with elastomer boot (1)	Steel roller plunger	Retractable steel roller lever plunger	M12 with metal end plunger	M16 with metal end plunger with elastomer boot (1)	M12 with steel roller plunger
------------------	-------------------	---	----------------------	--	----------------------------	--	-------------------------------

References

<p>Single-pole CO snap action + integral M12 4-pin connector</p>	<p>ZCMD21M12 + ZCE10 ⊖</p>	<p>ZCMD21M12 + ZCE11 ⊖</p>	<p>ZCMD21M12 + ZCE02 ⊖</p>	<p>ZCMD21M12 + ZCE24 ⊖</p>	<p>ZCMD21M12 + ZCEF0 ⊖</p>	<p>ZCMD21M12 + ZCEG1 ⊖</p>	<p>ZCMD21M12 + ZCEF2 ⊖</p>
<p>2-pole NC + NO snap action + integral M12 5-pin connector</p>	<p>ZCMD21C12 + ZCE10 ⊖</p>	<p>ZCMD21C12 + ZCE11 ⊖</p>	<p>ZCMD21C12 + ZCE02 ⊖</p>	<p>ZCMD21C12 + ZCE24 ⊖</p>	<p>ZCMD21C12 + ZCEF0 ⊖</p>	<p>ZCMD21C12 + ZCEG1 ⊖</p>	<p>ZCMD21C12 + ZCEF2 ⊖</p>
<p>2-pole NC + NC snap action + integral M12 5-pin connector</p>	<p>ZCMD29C12 + ZCE10 ⊖</p>	<p>ZCMD29C12 + ZCE11 ⊖</p>	<p>ZCMD29C12 + ZCE02 ⊖</p>	<p>ZCMD29C12 + ZCE24 ⊖</p>	<p>ZCMD29C12 + ZCEF0 ⊖</p>	<p>ZCMD29C12 + ZCEG1 ⊖</p>	<p>ZCMD29C12 + ZCEF2 ⊖</p>
Weight (kg)	0.085	0.085	0.090	0.105	0.100	0.125	0.110
<p>2-pole NC + NO snap action + M12 5-pin connector on 0.8 m flying lead</p>	<p>ZCMD21L08R12 + ZCE10 ⊖</p>	<p>ZCMD21L08R12 + ZCE11 ⊖</p>	<p>ZCMD21L08R12 + ZCE02 ⊖</p>	<p>ZCMD21L08R12 + ZCE24 ⊖</p>	<p>ZCMD21L08R12 + ZCEF0 ⊖</p>	<p>ZCMD21L08R12 + ZCEG1 ⊖</p>	<p>ZCMD21L08R12 + ZCEF2 ⊖</p>
Weight (kg)	0.150	0.150	0.155	0.170	0.165	0.190	0.175
Contact operation			(A) = cam displacement (P) = positive opening point		⊖ NC contact with positive opening operation		

Complementary characteristics not shown under general characteristics (see page 27)





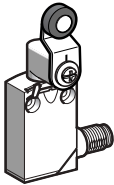
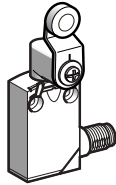
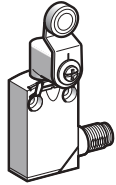
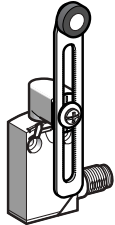
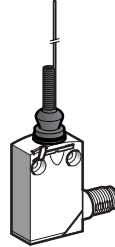

Switch actuation	On end	By 30° cam		On end	By 30° cam
Type of actuation					
Maximum actuation speed	0.5 m/s				0.1 m/s
Mechanical durability	10 million operating cycles				
Minimum force or torque	For tripping	8.5 N	2.5 N	8.5 N	7 N
	For positive opening	42.5 N	35 N	42.5 N	35 N
Positive operation	Although their design is identical to the pre-cabled switches, the switches incorporating an M12 4-pin connector cannot be marked with the ⊖ symbol because they are single-pole CO.				

(1) Nitrile for indoor use.

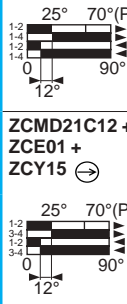
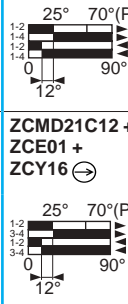
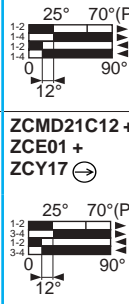
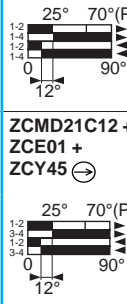
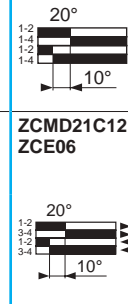
Limit switches

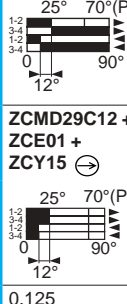
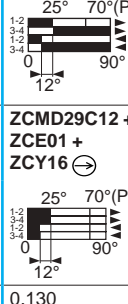
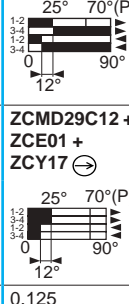
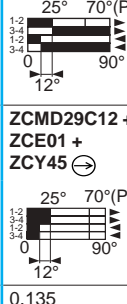
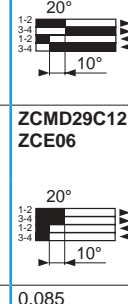
XC Standard range
Miniature design, metal, XCMD
Modular units
Connector

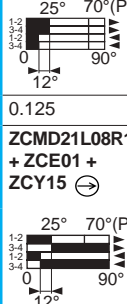
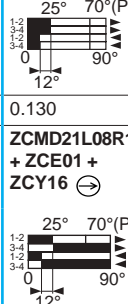
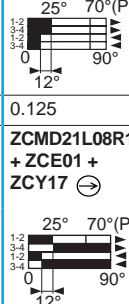
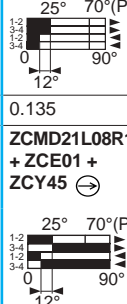
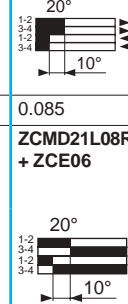
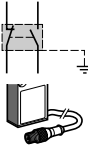
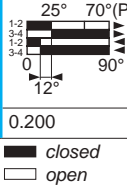
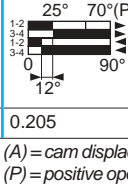
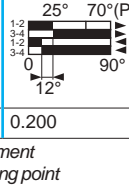
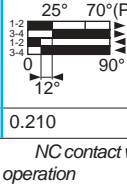
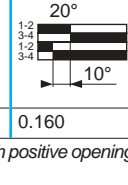
Type of head	Rotary (fixing by the body)				Multi-directional
					
Type of operator	Thermoplastic roller lever	Steel roller lever	Roller lever with ball bearing mounted roller	Variable length thermoplastic roller lever	"Cat's whisker" (1)

References					
 Single-pole CO snap action With integral M12 4-pin connector	ZCMD21M12 + ZCE01 + ZCY15 ⊖ 	ZCMD21M12 + ZCE01 + ZCY16 ⊖ 	ZCMD21M12 + ZCE01 + ZCY17 ⊖ 	ZCMD21M12 + ZCE01 + ZCY45 ⊖ 	ZCMD21M12 + ZCE06 
 2-pole NC + NO snap action With integral M12 5-pin connector	ZCMD21C12 + ZCE01 + ZCY15 ⊖ 	ZCMD21C12 + ZCE01 + ZCY16 ⊖ 	ZCMD21C12 + ZCE01 + ZCY17 ⊖ 	ZCMD21C12 + ZCE01 + ZCY45 ⊖ 	ZCMD21C12 + ZCE06 
 2-pole NC + NC snap action With integral M12 5-pin connector	ZCMD29C12 + ZCE01 + ZCY15 ⊖ 	ZCMD29C12 + ZCE01 + ZCY16 ⊖ 	ZCMD29C12 + ZCE01 + ZCY17 ⊖ 	ZCMD29C12 + ZCE01 + ZCY45 ⊖ 	ZCMD29C12 + ZCE06 
Weight (kg)	0.125	0.130	0.125	0.135	0.085
 2-pole NC + NO snap action With M12 5-pin connector on 0.8 m flying lead	ZCMD21L08R12 + ZCE01 + ZCY15 ⊖ 	ZCMD21L08R12 + ZCE01 + ZCY16 ⊖ 	ZCMD21L08R12 + ZCE01 + ZCY17 ⊖ 	ZCMD21L08R12 + ZCE01 + ZCY45 ⊖ 	ZCMD21L08R12 + ZCE06 
Weight (kg)	0.200	0.205	0.200	0.210	0.160
Contact operation	 closed  open		(A) = cam displacement (P) = positive opening point	NC contact with positive opening operation	

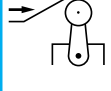
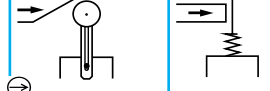
Complementary characteristics not shown under general characteristics (see page 27)		
Switch actuation	By 30° cam	
Type of actuation		
Maximum actuation speed	1.5 m/s	
Mechanical durability	10 million operating cycles	
Minimum force or torque	For tripping For positive opening	0.1 N.m 0.5 N.m
Positive operation	Although their design is identical to the pre-cabled switches, the switches incorporating an M12 4-pin connector cannot be marked with the ⊖ symbol because they are single-pole CO.	

(1) Value taken with actuation by moving part at 100 mm from the fixing.

Limit switches

XC Standard range
Miniature design, metal, XCMD
Connector cabling accessories

References of suitable pre-wired female connectors

Type of connector	M12 straight, 4-pin 4 A, 250 V	M12 straight, 5-pin 4 A, 24 V	M12 elbowed, 5-pin 4 A, 24 V
With cable	L = 2 m	XZCP1169L2	XZCP1264L2
	L = 5 m	XZCP1169L5	XZCP1264L5
	L = 10 m	XZCP1169L10	XZCP1264L10
Weight (kg)	0.105	0.115	0.115

Connections

XCMD with connector

4-pin, M12

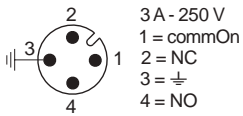

5-pin, M12

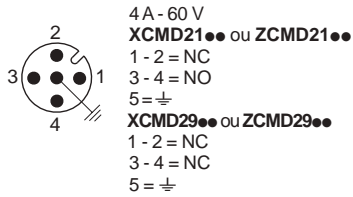

XZCP pre-wired female connectors

4-pin, M12

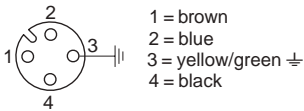

5-pin, M12

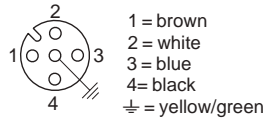

Dimensions

XZCP116●L●

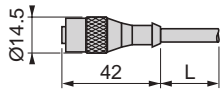

XZCP1264L●

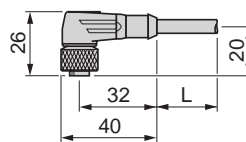

L: cable length 2, 5 or 10 m.

Distances required for plug-in connectors

M12 straight connector

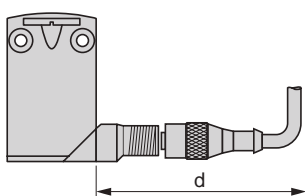

d : mini 65 mm, recommended 69 mm

M12 elbowed connector

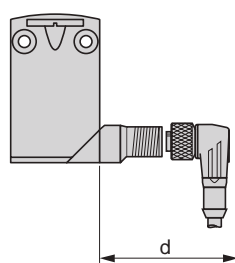

d : mini 42 mm, recommended 45 mm

Connector on flying lead

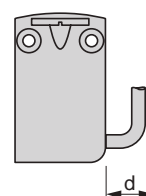

d : mini 20 mm

Limit switches

XC Standard range
Miniature design, metal, XCMD
Complete units
Connector

Dimensions

XCMD2110M12 and XCMD2110C12

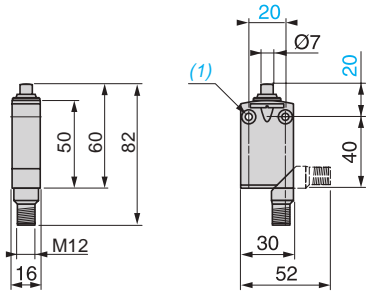

XCMD2111M12 and XCMD2111C12

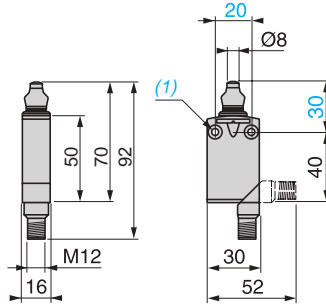

XCMD2102M12 and XCMD2102C12

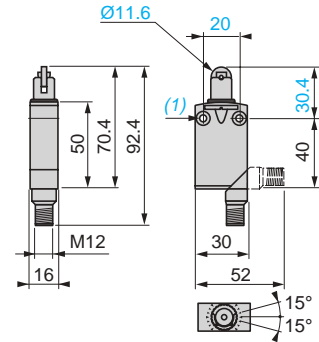

XCMD2124M12 and XCMD2124C12

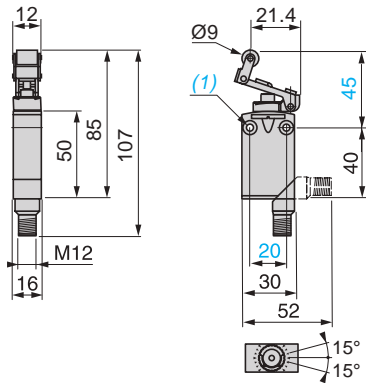

XCMD21F0M12 and XCMD21F0C12

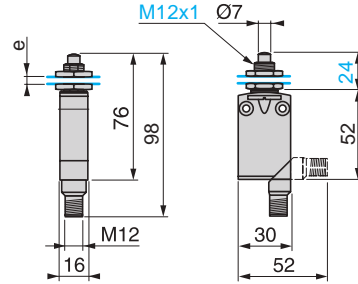

XCMD21G1M12 and XCMD21G1C12

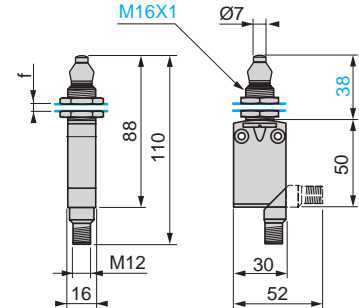

XCMD21F2M12 and XCMD21F2C12

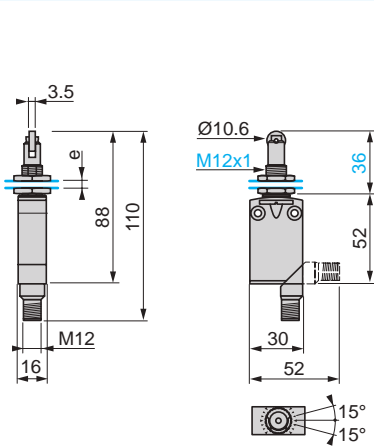

XCMD2145M12 and XCMD2145C12

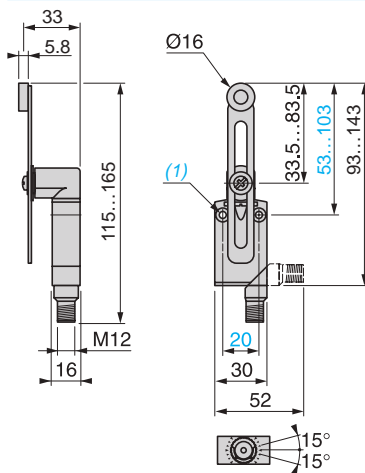

XCMD2115M12 /116M12 /117M12
XCMD2115C12 /116C12 /117C12

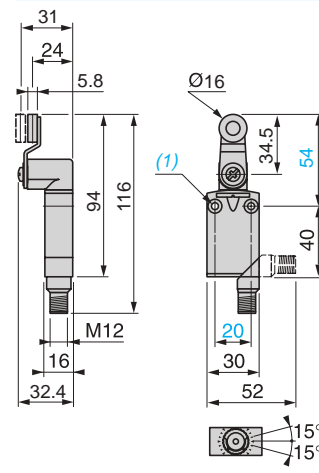

XCMD2106M12 and XCMD2106C12

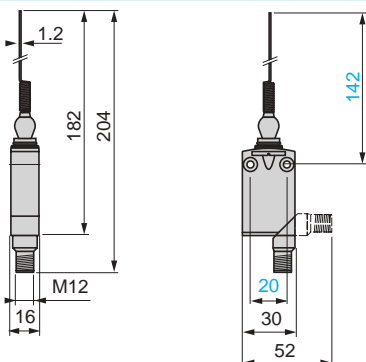

(1) 2 fixing holes Ø 4.2 mm, counterbored Ø 8 mm by 4 mm deep.
e: 8 mm max., panel cut-out Ø 12.5 mm, fixing nut thickness 3.5 mm.
f: 8 mm max., panel cut-out Ø 16.5 mm, fixing nut thickness 3.5 mm.

Limit switches

XC Standard range
Miniature design, metal, XCMD
Modular units
Connector

Dimensions (continued)

ZCMD21M12 + ZCE10
ZCMD2●C12 + ZCE10
ZCMD21L08●●● + ZCE10

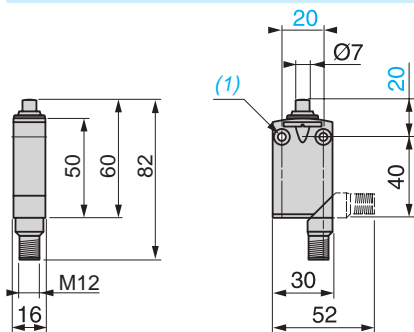

ZCMD21M12 + ZCE11
ZCMD2●C12 + ZCE11
ZCMD21L08●●● + ZCE11

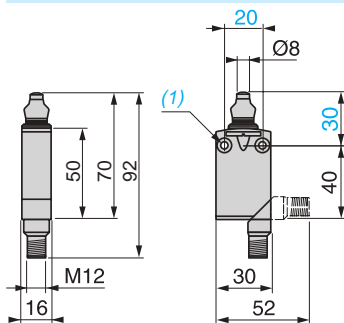

ZCMD21M12 + ZCE02
ZCMD2●C12 + ZCE02
ZCMD21L08●●● + ZCE02

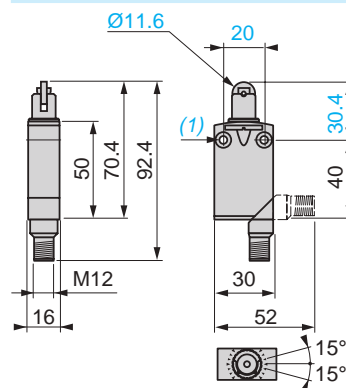

ZCMD21M12 + ZCE24
ZCMD2●C12 + ZCE24
ZCMD21L08●●● + ZCE24

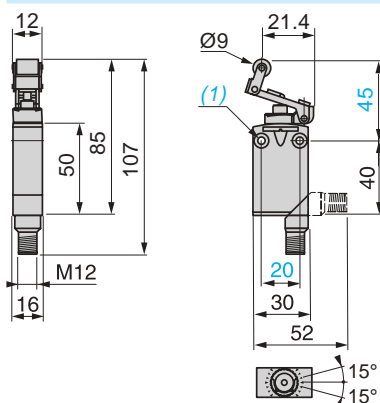

ZCMD21M12 + ZCEF0
ZCMD2●C12 + ZCEF0
ZCMD21L08●●● + ZCEF0

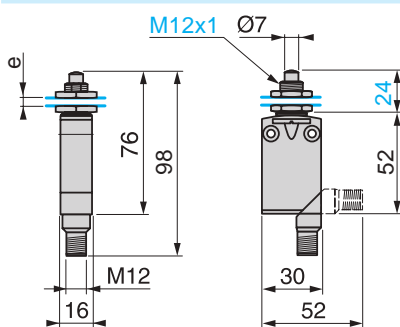

ZCMD21M12 + ZCEG1
ZCMD2●C12 + ZCEG1
ZCMD21L08●●● + ZCEG1

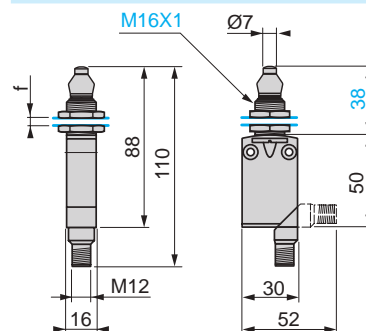

(1) 2 fixing holes Ø 4.2 mm, counterbored Ø 8 mm by 4 mm deep.

e: 8 mm max., panel cut-out Ø 12.5 mm, fixing nut thickness 3.5 mm.

f: 8 mm max., panel cut-out Ø 16.5 mm, fixing nut thickness 3.5 mm.

Limit switches

XC Standard range
 Miniature design, metal, XCMD
 Modular units
 Connector

Dimensions (continued)

ZCMD21M12 + ZCEF2
 ZCMD2●C12 + ZCEF2
 ZCMD21L08●●● + ZCEF2

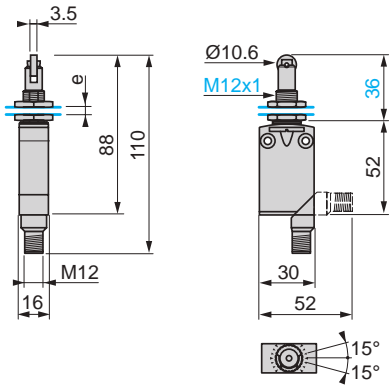

ZCMD21M12 + ZCE01 + ZCY45
 ZCMD2●C12 + ZCE01 + ZCY45
 ZCMD21L08●●● + ZCE01 + ZCY45

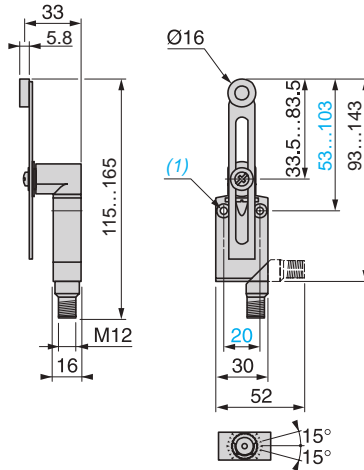

ZCMD21M12 + ZCE01 + ZCY1●
 ZCMD2●C12 + ZCE01 + ZCY1●
 ZCMD21L08●●● + ZCE01 + ZCY1●

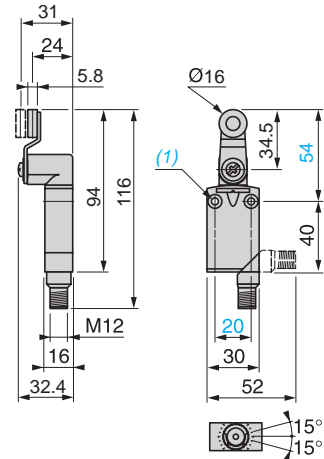

ZCMD21M12 + ZCE06
 ZCMD2●C12 + ZCE06
 ZCMD21L08●●● + ZCE06

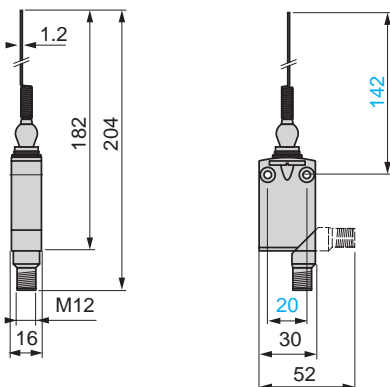

(1) 2 fixing holes Ø 4.2 mm, counterbored Ø 8 mm by 4 mm deep.
 e: 8 mm max., panel cut-out Ø 12.5 mm, fixing nut thickness 3.5 mm.
 f: 8 mm max., panel cut-out Ø 16.5 mm, fixing nut thickness 3.5 mm.

Limit switches

XC Standard range

Miniature design, metal, XCMD

Variable composition

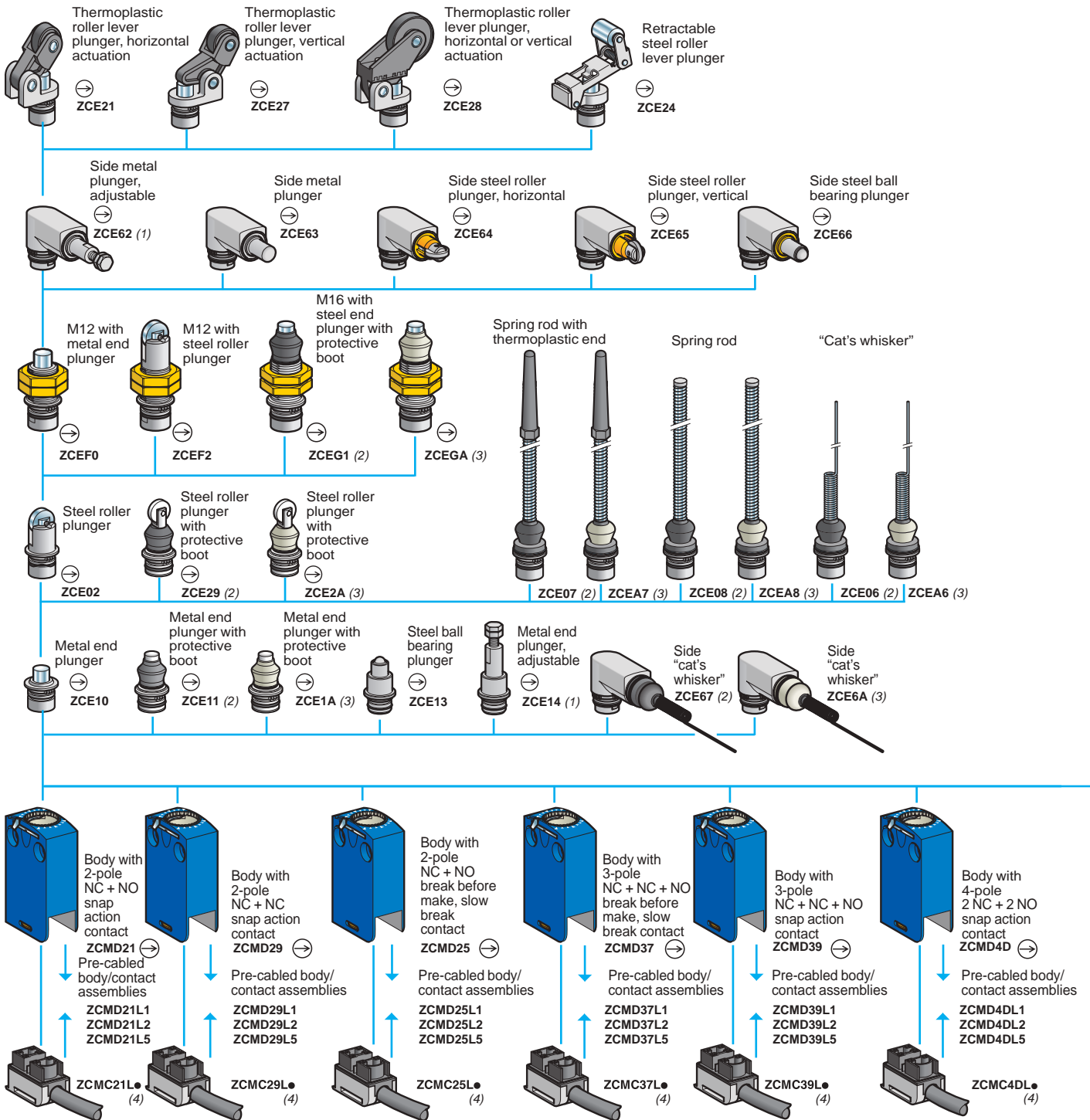

(1) A minimum 5 mm of threaded length must be maintained inside the head. Plunger length can be adjusted from 30.5 to 35.5 mm.

(2) Nitrile boot for indoor use.

(3) Silicone boot for outdoor use.

(4) Connection components: replace the "●" in the reference with the required cable length in metres (1, 2, 3, 5, 7 or 10 m).

For example, ZCMC21L● becomes ZCMC21L7 for a 7 m cable.

Note: Only cable lengths of 1, 2 and 5 m are available for connection components ZCMC37L●, ZCMC39L● and ZCMC4DL●.

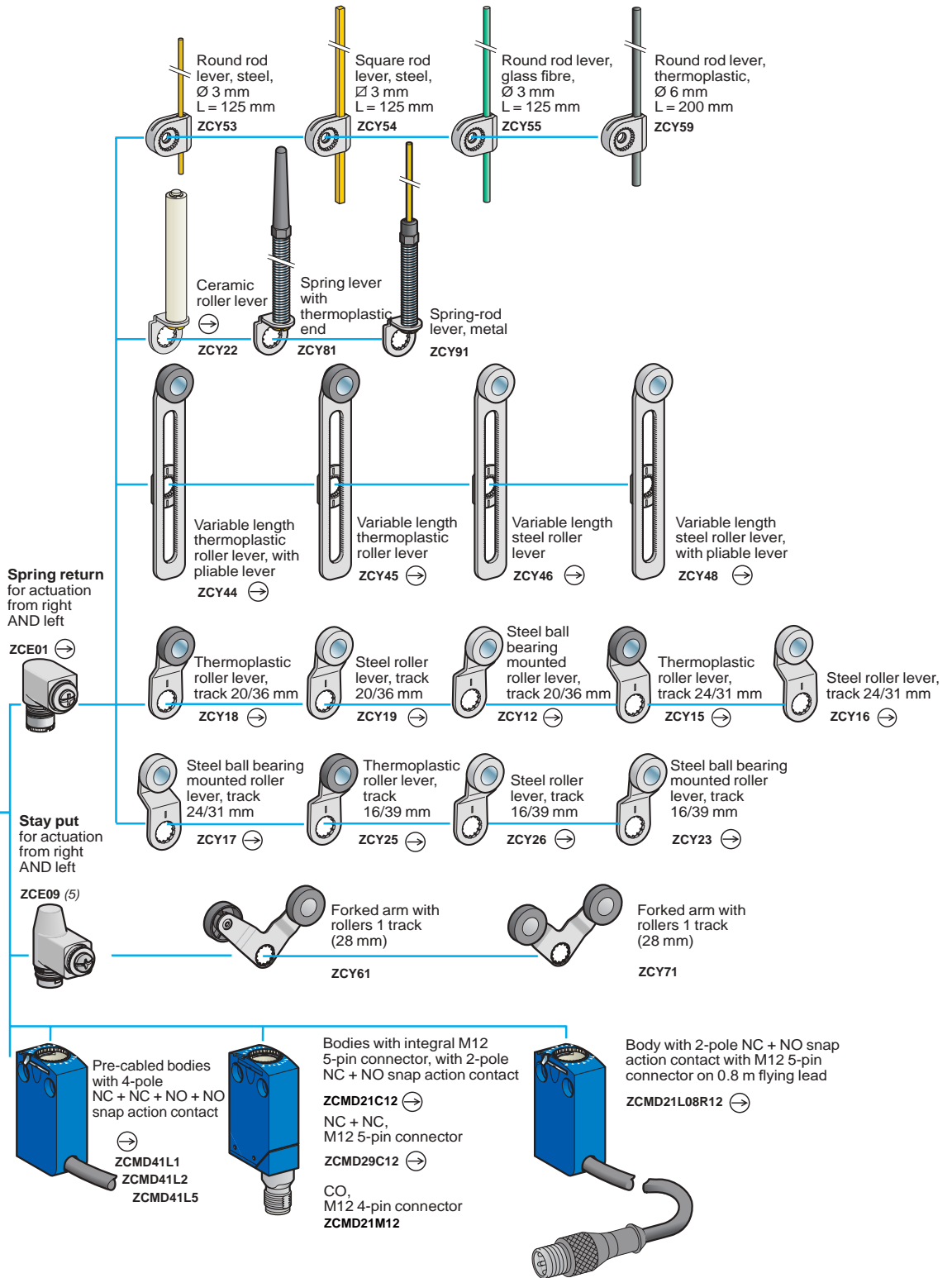

(5) Suitable with bodies: ZCMD21, ZCMD29, ZCMD39, ZCMD41, ZCMD4D, ZCMD21C12, ZCMD21M12, ZCMD29C12 or ZCMD21L08R12.

Limit switches

XC Standard range
Miniature design, metal, XCMD
Body/contact assemblies

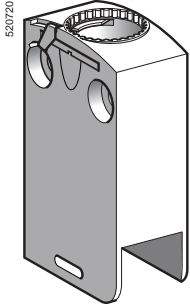

ZCMD6●
ZCMD7●
ZCMD4D

Body/contact assemblies					
Type of contact	Positive operation (1)	Scheme	Type of contact	Reference	Weight kg
2-pole					
NC + NO snap action	⊖		Standard	ZCMD21	0.055
			Gold plated	ZCMD61	0.055
NC + NC snap action	⊖		Standard	ZCMD29	0.055
NC + NO break before make, slow break	⊖		Standard	ZCMD25	0.055
			Gold plated	ZCMD65	0.055
3-pole					
NC + NC + NO break before make, slow break	⊖		Standard	ZCMD37	0.055
NC + NC + NO snap action	⊖		Standard	ZCMD39	0.055
4-pole					
2 NC + 2 NO snap action	⊖		Standard	ZCMD4D	0.055

(1) ⊖ bodies with contacts assuring positive opening operation.

Limit switches

XC Standard range

Miniature design, metal, XCMD
Pre-cabled body/contact assemblies

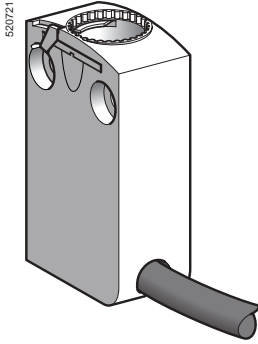

ZCMD●●●●

Body/contact assemblies with removable cable					
Type of contact	Positive operation (1)	Scheme	Length of cable in metres	Reference	Weight kg
2-pole					
NC + NO snap action	⊕		1	ZCMD21L1	0.160
			2	ZCMD21L2	0.250
			5	ZCMD21L5	0.520
NC + NC snap action	⊕		1	ZCMD29L1	0.160
			2	ZCMD29L2	0.250
			5	ZCMD29L2	0.520
NC + NO break before make, slow break	⊕		1	ZCMD25L1	0.160
			2	ZCMD25L2	0.250
			5	ZCMD25L5	0.520
3-pole					
NC + NC + NO break before make, slow break	⊕		1	ZCMD37L1	0.160
			2	ZCMD37L2	0.250
			5	ZCMD37L5	0.520
NC + NC + NO snap action	⊕		1	ZCMD39L1	0.160
			2	ZCMD39L2	0.250
			5	ZCMD39L5	0.520
4-pole					
2 NC + 2 NO snap action	⊕		1	ZCMD4DL1	0.160
			2	ZCMD4DL2	0.250
			5	ZCMD4DL5	0.520
Pre-cabled bodies/contact assemblies (fixed cable)					
4-pole					
2 NC + 2 NO snap action	⊕		1	ZCMD41L1	0.160
			2	ZCMD41L2	0.250
			5	ZCMD41L5	0.520
Pre-cabled bodies with gold contacts (fixed cable)					
4-pole					
2 NC + 2 NO snap action	⊕		1	ZCMD81L1	0.160
			2	ZCMD81L2	0.250
			5	ZCMD81L5	0.520

(1) ⊕ bodies with contacts assuring positive opening operation.

Limit switches

XC Standard range

Miniature design, metal, XCMD
Connection components

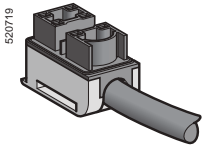

ZCMC2●L●●
ZCMC3●L●●

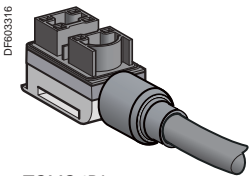

ZCMC4DL●

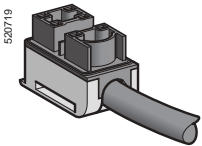

ZCMC21E●

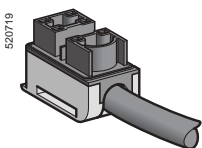

ZCMC21T●

Pre-cabled connection components with PVC cable

2-pole

Type of contact	Scheme	Length of cable in metres	Reference	Weight kg
NC + NO snap action		1	ZCMC21L1	0.100
		2	ZCMC21L2	0.190
		3	ZCMC21L3	0.280
		5	ZCMC21L5	0.460
		7	ZCMC21L7	0.700
10	ZCMC21L10	0.970		

NC + NC snap action		1	ZCMC29L1	0.100
		2	ZCMC29L2	0.190
		3	ZCMC29L3	0.280
		5	ZCMC29L5	0.460
		7	ZCMC29L7	0.700
10	ZCMC29L10	0.970		

NC + NO break before make, slow break		1	ZCMC25L1	0.100
		2	ZCMC25L2	0.190
		3	ZCMC25L3	0.280
		5	ZCMC25L5	0.460
		7	ZCMC25L7	0.700
10	ZCMC25L10	0.970		

3-pole

NC + NC + NO break before make, slow break		5	ZCMC37L5	0.460
--	--	---	----------	-------

NC + NC + NO snap action		2	ZCMC39L2	0.190
		5	ZCMC39L5	0.460

4-pole

2 NC + 2 NO snap action		1	ZCMC4DL1	0.100
		2	ZCMC4DL2	0.190
		5	ZCMC4DL5	0.460

Pre-cabled connection components with CEI cable

(Connitato Elettrotecnico Italiano) (1)

Type of contact	Scheme	Length of CEI cable in metres	Reference	Weight kg
2-pole NC + NO snap action		2	ZCMC21E2	0.190
		3	ZCMC21E3	0.280
		5	ZCMC21E5	0.460

Pre-cabled connection components with halogen free cable (2)

Type of contact	Positive operation (3)	Scheme	Length of cable in metres	Reference	Weight kg
2-pole NC + NO snap action		1	1	ZCMC21T1	0.130
		2	2	ZCMC21T2	0.250
		5	5	ZCMC21T5	0.520

(1) Cable not UL or CSA certified.

(2) For other types of contacts and cable, please contact our Customer Care Centre.

(3) ⊕ bodies with contacts assuring positive opening operation.

Limit switches

XC Standard range
Miniature design, metal, XCMD
Separate parts

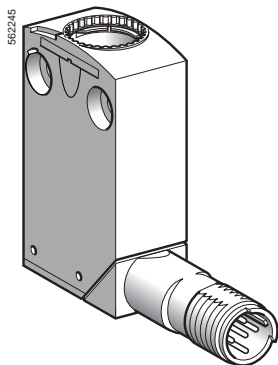

ZCMD61●●●

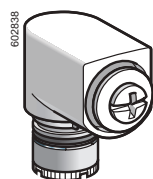

ZCE05



XCMZ06



XCMZ07

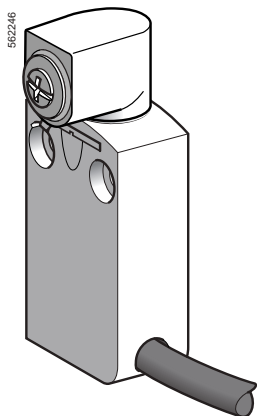

XCMD2●01L1

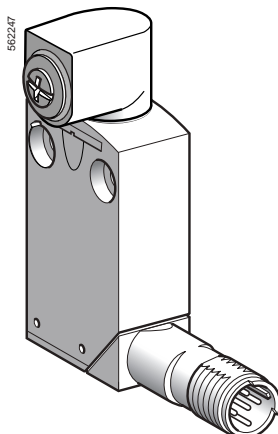

XCMD2101●12

Bodies with gold contacts, connector

Type of contact	Positive operation (1)	Scheme	Connector	Reference	Weight kg
2-pole					
NC + NO snap action	—		M12 5-pin	ZCMD61C12	0.065
NC + NC snap action	—		M12 5-pin	ZCMD69C12	0.065

Accessories

Description	Positive operation (1)	Suitable levers for use with head	Reference	Weight kg
Rotary head, without lever, spring return, for actuation from right AND left or from right OR left		ZCY12, ZCY15, ZCY16, ZCY17, ZCY18, ZCY19, ZCY22, ZCY23, ZCY25, ZCY26, ZCY39, ZCY53, ZCY54, ZCY55, ZCY81	ZCE05	0.045
Spacer for mounting multi-track XCMD	—	—	XCMZ06	0.005
Spacer for angular positioning of heads with adjustable levers, for values other than -90°, 0° and 90°	—	—	XCMZ07	0.005

Pre-cabled body/contact assemblies, with rotary head (without operating lever)

Type of contact	Positive operation (1)	Scheme	Length of cable in metres	Reference	Weight kg
2-pole					
NC + NO snap action			1	XCMD2101L1	0.180

Body/contact assemblies with rotary head (without operating lever), connector

Type of contact	Positive operation (1)	Scheme	Connector	Reference	Weight kg
2-pole					
NC + NO snap action			M12 5-pin	XCMD2101C12	0.110
Single-pole					
CO snap action	—		M12 4-pin	XCMD2101M12	0.110

(1) bodies with contacts or head assuring positive opening operation.

Limit switches

XC Standard range

Miniature design, metal, XCMV

for mobile equipment

The range of XCMV limit switches is an offer dedicated to mobile equipment:

- special connectors
- a metal body for robustness
- compact dimensions (among the smallest on the market)
- IP 69 degree of protection, for high-pressure cleaning
- for outdoor use at -25 °...+70 °C

Complete units
with Deutsch DT04-4P connector

□ With head for linear (plunger) and rotary (lever) movement



Page 53

Complete units
with AMP Superseal 1.5 connector

□ With head for linear (plunger) and rotary (lever) movement



Page 54

Complete units
with M12 connector

□ With head for linear (plunger) and rotary (lever) movement



Page 55

Limit switches

XC Standard range
Miniature design, metal, XCMV
for mobile equipment

Modular units

Body with Deutsch DT04-4P connector

□ With head for linear (plunger) and rotary (lever) movement



Pages 56 and 57

Modular units

Body with AMP Superseal 1.5 connector

□ With head for linear (plunger) and rotary (lever) movement



Pages 58 and 59

Modular units

Body with M12 connector

□ With head for linear (plunger) and rotary (lever) movement



Pages 60 and 61

Modular units

Pre-cabled body

□ With head for linear (plunger) and rotary (lever) movement



Pages 62 and 63

Limit switches

XC Standard range

Miniature design, metal, XCMV
for mobile equipment

Environmental characteristics		
Product certifications		CE, cURus
Conformity to standards	Products	EN/IEC 60947-5-1, UL 508, CSA C22-2 n°14, GB/T 14048.5
	Machine assemblies	EN/IEC 60204-1
Protective treatment		Standard version: "TC"
Ambient air temperature	For operation	- 25...+ 70 °C (- 40...+ 70 °C with ZCE106, ZCE026 and ZCE016 heads)
	For storage	- 40...+ 70 °C
Vibration resistance		± 1.76 mm (10...60 Hz), 25 gn (61...500 Hz) conforming to IEC 60068-2-6
Shock resistance		40 gn (11 ms) conforming to IEC 60068-2-27
Protection against electric shock		Class III conforming to IEC 61140, class 2 conforming to UL 508
Degree of protection	Switches with 4-pin M12 connector	IP 66, IP 67 and IP 69 conforming to EN/IEC 60529 ; IK 04 conforming to EN 62262
	Switches with 4-pin Deutsch DT04-4P or AMP Superseal 1.5 connector	IP 66, IP 67 and IP 69 conforming to EN/IEC 60529 ; IK 06 conforming to EN 62262
	Pre-cabled switches	IP 66 and IP 67 conforming to EN/IEC 60529
Materials		Body: Zamak, heads: Zamak, connectors: thermoplastic, cable: PvR
Repeat accuracy		0.1 mm on the tripping points, with 1 million operating cycles for head with end plunger

Contact block characteristics		
Rated operational characteristics	Switches with 4-pin M12 connector	~ AC-14; Ue = 24 V, Ie = 3 A, Ith = 4 A --- DC-13; Ue = 24 V, Ie = 1 A, conforming to IEC 60947-5-1, EN 60947-5-1
	Pre-cabled switches or switches with 4-pin Deutsch DT04-4P or AMP Superseal 1.5 connector	~ AC-14; Ue = 24 V, Ie = 3 A, Ith = 6 A --- DC-13; Ue = 24 V, Ie = 1 A, conforming to IEC 60947-5-1, EN 60947-5-1
Rated insulation voltage		Ui = 36 V degree of pollution 3 conforming to IEC 60947-5-1 Ui = 36 V conforming to UL 508, CSA C22-2 no. 14
Rated impulse withstand voltage		U imp = 0.8 kV conforming to IEC 60947-1, IEC 60664
Positive operation (depending on model)		NC contacts with positive opening operation conforming to IEC 60947-5-1
Resistance across terminals		≤ 25 mΩ conforming to IEC 60255-7 category 3
Short-circuit protection.		6 A cartridge fuse type gG (gl)
Minimum actuation speed (for head with end plunger)		Snap-action contact: 0.01 m/minute, slow-break contact: 6 m/minute
Electrical durability		<ul style="list-style-type: none"> ■ Conforming to IEC 60947-5-1 Appendix C ■ Utilisation categories AC-14 and DC-13 ■ Maximum operating rate: 3600 operating cycles/hour ■ Load factor: 0.5

AC supply
~ 50/60 Hz
mm inductive circuit

XCMV snap-action (NC+NO contact)

XCMV slow-break (NC+NO contact)

Switches with M12 connector

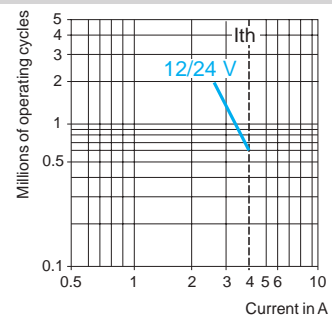
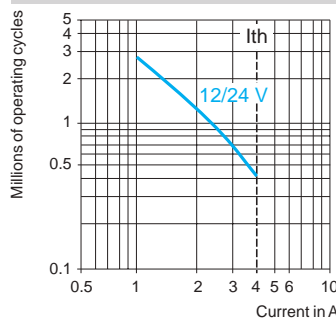

Pre-cabled switches or switches with Deutsch DT04-4P or AMP Superseal 1.5 connector

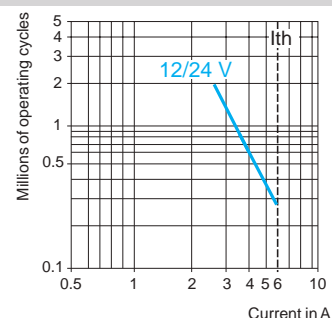
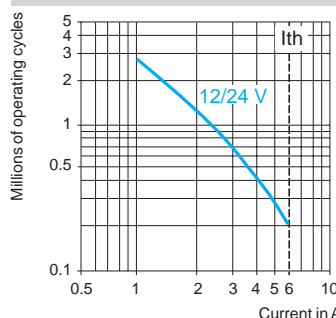

DC supply ---

Power broken in W for 0.1 million operating cycles		
Voltage	V	24
mm	A	2

Power broken in W for 1.3 million operating cycles		
Voltage	V	24
mm	A	0.5

Limit switches

XC Standard range
Miniature design, metal, XCMV
Complete units for mobile equipment

Type of head	Plunger (fixing by the body)	Rotary (fixing by the body)
--------------	------------------------------	-----------------------------



Form conforming to EN 50047	B	C	A
Type of operator	Metal end plunger	Steel roller plunger	Thermoplastic roller lever (1)
Positive operation			

References of complete units with male Deutsch DT04-4P connector

2-pole NC + NO snap action	XCMV2110D44 	XCMV2102D44 	XCMV2115D44
2-pole NC + NO break before make, slow break	XCMV2510D44 	XCMV2502D44 	XCMV2515D44
Weight (kg)	0.090	0.090	0.130

Contact operation (A) = cam displacement (P) = positive opening point

Complementary characteristics not shown under general characteristics (see page 52)

Switch actuation	On end	By 30° cam	
Type of actuation			
Maximum actuation speed	0.5 m/s	0.5 m/s	1.5 m/s
Mechanical durability (in millions of operating cycles)	10		
Minimum force or torque	For tripping	8.5 N	7 N
	For positive opening	42.5 N	35 N
			0.1 N.m
			0.5 N.m

(1) Can be adjusted throughout 360° in 15° steps.

Limit switches

XC Standard range
Miniature design, metal, XCMV
Complete units for mobile equipment

Type of head	Plunger (fixing by the body)	Rotary (fixing by the body)
--------------	------------------------------	-----------------------------



Form conforming to EN 50047	B	C	A
Type of operator	Metal end plunger	Steel roller plunger	Thermoplastic roller lever (1)
Positive operation			

References of complete units with male AMP Superseal 1.5 connector

2-pole NC + NO snap action	<p>XCMD2110AM4</p>	<p>XCMD2102AM4</p>	<p>XCMD2115AM4</p>
2-pole NC + NO break before make, slow break	<p>XCMD2510AM4</p>	<p>XCMD2502AM4</p>	<p>XCMD2515AM4</p>
Weight (kg)	0.090	0.090	0.130
Contact operation			(A) = cam displacement (P) = positive opening point

Characteristics

Switch actuation	On end	By 30° cam		
Type of actuation				
Maximum actuation speed	0.5 m/s	0.5 m/s	1.5 m/s	
Mechanical durability (in millions of operating cycles)	10			
Minimum force or torque	For tripping	8.5 N	7 N	0.1 N.m
	For positive opening	42.5 N	35 N	0.5 N.m

(1) Can be adjusted throughout 360° in 15° steps.

Limit switches

XC Standard range

Miniature design, metal, XCMV

Complete units for mobile equipment

Type of head	Plunger (fixing by the body)	Rotary (fixing by the body)
--------------	------------------------------	-----------------------------



Form conforming to EN 50047	B	C	A
Type of operator	Metal end plunger	Steel roller plunger	Thermoplastic roller lever (1)
Positive operation			

References of complete units with M12 connector

2-pole NC + NO snap action	XCMV2110M12 	XCMV2102M12 	XCMV2115M12
2-pole NC + NO break before make, slow break	XCMV2510M12 	XCMV2502M12 	XCMV2515M12
Weight (kg)	0.090	0.090	0.130

Contact operation closed open (A) = cam displacement (P) = positive opening point

Complementary characteristics not shown under general characteristics (see page 52)

Switch actuation	On end	By 30° cam	
Type of actuation			
Maximum actuation speed	0.5 m/s	0.5 m/s	1.5 m/s
Mechanical durability (in millions of operating cycles)	10		
Minimum force or torque	For tripping	8.5 N	7 N
	For positive opening	42.5 N	35 N
			0.1 N.m
			0.5 N.m

(1) Can be adjusted throughout 360° in 15° steps.

Limit switches

XC Standard range
Miniature design, metal, XCMV
Modular units for mobile equipment

Type of head	Plunger (fixing by the body)						Plunger (fixing by the head)

Type of operator	Metal end plunger	Metal end plunger -40 °C (1)	Metal end plunger with elastomer boot (2)	Steel roller plunger	Steel roller plunger -40 °C (1)	Retractable steel roller lever plunger	M12 with metal end plunger
------------------	-------------------	------------------------------	---	----------------------	---------------------------------	--	----------------------------

References of modular units (body with male Deutsch DT04-4P connector and removable terminal block)

2-pole NC + NO snap action 	ZCMV21D44 + ZCE10 ⊕ 	ZCMV21D44 + ZCE106 ⊕ 	ZCMV21D44 + ZCE11 ⊕ 	ZCMV21D44 + ZCE02 ⊕ 	ZCMV21D44 + ZCE026 ⊕ 	ZCMV21D44 + ZCE24 ⊕ 	ZCMV21D44 + ZCEF0 ⊕
2-pole NC + NO break before make, slow break 	ZCMV25D44 + ZCE10 ⊕ 	ZCMV25D44 + ZCE106 ⊕ 	ZCMV25D44 + ZCE11 ⊕ 	ZCMV25D44 + ZCE02 ⊕ 	ZCMV25D44 + ZCE026 ⊕ 	ZCMV25D44 + ZCE24 ⊕ 	ZCMV25D44 + ZCEF0 ⊕
2-pole NC + NC snap action 	ZCMV29D44 + ZCE10 ⊕ 	ZCMV29D44 + ZCE106 ⊕ 	ZCMV29D44 + ZCE11 ⊕ 	ZCMV29D44 + ZCE02 ⊕ 	ZCMV29D44 + ZCE026 ⊕ 	ZCMV29D44 + ZCE24 ⊕ 	ZCMV29D44 + ZCEF0 ⊕

Contact operation (A) = cam displacement (P) = positive opening point ⊕ NC contact with positive opening operation

Complementary characteristics not shown under general characteristics (see page 52)

Switch actuation	On end	By 30° cam	On end		
Type of actuation					
Maximum actuation speed	0.5 m/s				
Mechanical durability	10 million operating cycles				
Nominal force or torque	For tripping	8.5 N	7 N	2.5 N	8.5 N
	For positive opening	42.5 N	35 N	12.5 N	42.5 N
Connection	Deutsch DT04-4P connector				

(1) For use at -40 °C.
(2) Nitrile for indoor use.
(3) Value taken with actuation by moving part at 100 mm from the fixing.

Plunger (fixing by the head)	Rotary (fixing by the body)						Multi-directional
------------------------------	-----------------------------	--	--	--	--	--	-------------------



M16 with metal end plunger with elastomer boot	M12 with steel roller plunger	Thermoplastic roller lever	Thermoplastic roller lever -40 °C (1)	Steel roller lever	Roller lever with ball bearing mounted roller	Variable length thermoplastic roller lever	"Cat's whisker" (3)
--	-------------------------------	----------------------------	---------------------------------------	--------------------	---	--	---------------------

ZCMV21D44 + ZCEG1 	ZCMV21D44 + ZCEF2 	ZCMV21D44 + ZCE01 + ZCY15 	ZCMV21D44 + ZCE016 + ZCY15 	ZCMV21D44 + ZCE01 + ZCY16 	ZCMV21D44 + ZCE01 + ZCY17 	ZCMV21D44 + ZCE01 + ZCY45 	ZCMV21D44 + ZCE06
ZCMV25D44 + ZCEG1 	ZCMV25D44 + ZCEF2 	ZCMV25D44 + ZCE01 + ZCY15 	ZCMV25D44 + ZCE016 + ZCY15 	ZCMV25D44 + ZCE01 + ZCY16 	ZCMV25D44 + ZCE01 + ZCY17 	ZCMV25D44 + ZCE01 + ZCY45 	ZCMV25D44 + ZCE06
ZCMV29D44 + ZCEG1 	ZCMV29D44 + ZCEF2 	ZCMV29D44 + ZCE01 + ZCY15 	ZCMV29D44 + ZCE016 + ZCY15 	ZCMV29D44 + ZCE01 + ZCY16 	ZCMV29D44 + ZCE01 + ZCY17 	ZCMV29D44 + ZCE01 + ZCY45 	ZCMV29D44 + ZCE06

closed
 open

(A) = cam displacement
 (P) = positive opening point

NC contact with positive opening operation

On end	By 30° cam			By any moving part	
0.5 m/s	0.1 m/s		1.5 m/s	1.5 m/s	1 m/s
10 million operating cycles				10 million	5 million
8.5 N	7 N.m		0.1 N.m	0.1 N.m	0.1 N.m
42.5 N	35 N.m		0.5 N.m	0.5 N.m	-

Deutsch DT04-4P connector

Limit switches

XC Standard range
Miniature design, metal, XCMV
Modular units for mobile equipment

Type of head	Plunger (fixing by the body)						Plunger (fixing by the head)
Type of operator	Metal end plunger	Metal end plunger -40 °C (1)	Metal end plunger with elastomer boot (2)	Steel roller plunger	Steel roller plunger -40 °C (1)	Retractable steel roller lever plunger	M12 with metal end plunger

References of modular units (body with male AMP Superseal 1.5 connector and removable terminal block)							
2-pole "NC + NO" snap action	ZCMD21AM4 + ZCE10	ZCMD21AM4 + ZCE106	ZCMD21AM4 + ZCE11	ZCMD21AM4 + ZCE02	ZCMD21AM4 + ZCE026	ZCMD21AM4 + ZCE24	ZCMD21AM4 + ZCEF0
2-pole NC + NO break before make, slow break	ZCMD25AM4 + ZCE10	ZCMD25AM4 + ZCE106	ZCMD25AM4 + ZCE11	ZCMD25AM4 + ZCE02	ZCMD25AM4 + ZCE026	ZCMD25AM4 + ZCE24	ZCMD25AM4 + ZCEF0
2-pole NC + NC snap action	ZCMD29AM4 + ZCE10	ZCMD29AM4 + ZCE106	ZCMD29AM4 + ZCE11	ZCMD29AM4 + ZCE02	ZCMD29AM4 + ZCE026	ZCMD29AM4 + ZCE24	ZCMD29AM4 + ZCEF0
Contact operation			(A) = cam displacement (P) = positive opening point	⊖ NC contact with positive opening operation			

Complementary characteristics not shown under general characteristics (see page 52)					
Switch actuation	On end	By 30° cam		On end	
Type of actuation					
Maximum actuation speed	0.5 m/s				
Mechanical durability	10 million operating cycles				
Nominal force or torque	For tripping	8.5 N	7 N	2.5 N	8.5 N
	For positive opening	42.5 N	35 N	12.5 N	42.5 N
Connection	Male AMP Superseal 1.5 connector				

(1) For use at -40 °C.
(2) Nitrile for indoor use.
(3) Value taken with actuation by moving part at 100 mm from the fixing.

Plunger (fixing by the head)	Rotary (fixing by the body)						Multi-directional
------------------------------	-----------------------------	--	--	--	--	--	-------------------



M16 with metal end plunger with elastomer boot	M12 with steel roller plunger	Thermoplastic roller lever	Thermoplastic roller lever -40 °C (1)	Steel roller lever	Roller lever with ball bearing mounted roller	Variable length thermoplastic roller lever	"Cat's whisker" (3)
--	-------------------------------	----------------------------	---------------------------------------	--------------------	---	--	---------------------

ZCMD21AM4 + ZCEG1 (⊕)	ZCMD21AM4 + ZCEF2 (⊖)	ZCMD21AM4 + ZCE01 + ZCY15 (⊕)	ZCMD21AM4 + ZCE016 + ZCY15 (⊖)	ZCMD21AM4 + ZCE01 + ZCY16 (⊕)	ZCMD21AM4 + ZCE01 + ZCY17 (⊖)	ZCMD21AM4 + ZCE01 + ZCY45 (⊕)	ZCMD21AM4 + ZCE06
ZCMD25AM4 + ZCEG1 (⊕)	ZCMD25AM4 + ZCEF2 (⊖)	ZCMD25AM4 + ZCE01 + ZCY15 (⊕)	ZCMD25AM4 + ZCE016 + ZCY15 (⊖)	ZCMD25AM4 + ZCE01 + ZCY16 (⊕)	ZCMD25AM4 + ZCE01 + ZCY17 (⊖)	ZCMD25AM4 + ZCE01 + ZCY45 (⊕)	ZCMD25AM4 + ZCE06
ZCMD29AM4 + ZCEG1 (⊕)	ZCMD29AM4 + ZCEF2 (⊖)	ZCMD29AM4 + ZCE01 + ZCY15 (⊕)	ZCMD29AM4 + ZCE016 + ZCY15 (⊖)	ZCMD29AM4 + ZCE01 + ZCY16 (⊕)	ZCMD29AM4 + ZCE01 + ZCY17 (⊖)	ZCMD29AM4 + ZCE01 + ZCY45 (⊕)	ZCMD29AM4 + ZCE06

■ closed
□ open

(A) = cam displacement
(P) = positive opening point

⊕ NC contact with positive opening operation









On end	By 30° cam		By any moving part	
0.5 m/s	0.1 m/s	1.5 m/s	1.5 m/s	1 m/s
10 million operating cycles			10 million	5 million
8.5 N	7 N.m	0.1 N.m	0.1 N.m	0.1 N.m
42.5 N	35 N.m	0.5 N.m	0.5 N.m	-

Male AMP Superseal 1.5 connector

Limit switches

XC Standard range



Miniature design, metal, XCMV
Modular units for mobile equipment

Type of head	Plunger (fixing by the body)						Plunger (fixing by the head)
							
							
Type of operator	Metal end plunger	Metal end plunger - 40 °C (1)	Metal end plunger with elastomer boot (2)	Steel roller plunger	Steel roller plunger - 40 °C (1)	Retractable steel roller lever plunger	M12 with metal end plunger

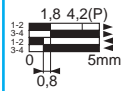
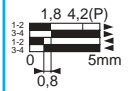
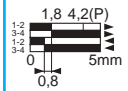
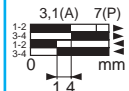
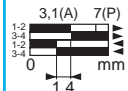
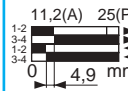
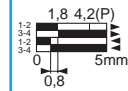
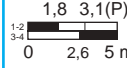
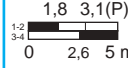
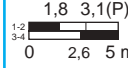
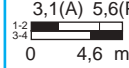
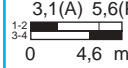
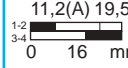
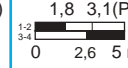
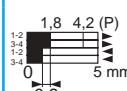
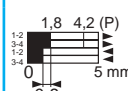
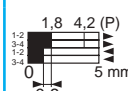
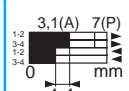
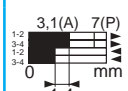
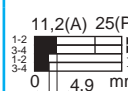
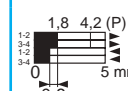
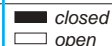
References of modular units (body with male M12 connector and removable terminal block)

2-pole "NC + NO" snap action	ZCMV21M12 + ZCE10 ⊕ 	ZCMV21M12 + ZCE106 ⊕ 	ZCMV21M12 + ZCE11 ⊕ 	ZCMV21M12 + ZCE02 ⊕ 	ZCMV21M12 + ZCE026 ⊕ 	ZCMV21M12 + ZCE24 ⊕ 	ZCMV21M12 + ZCEF0 ⊕ 
2-pole NC + NO break before make, slow break	ZCMV25M12 + ZCE10 ⊕ 	ZCMV25M12 + ZCE106 ⊕ 	ZCMV25M12 + ZCE11 ⊕ 	ZCMV25M12 + ZCE02 ⊕ 	ZCMV25M12 + ZCE026 ⊕ 	ZCMV25M12 + ZCE24 ⊕ 	ZCMV25M12 + ZCEF0 ⊕ 
2-pole NC + NC snap action	ZCMV29M12 + ZCE10 ⊕ 	ZCMV29M12 + ZCE106 ⊕ 	ZCMV29M12 + ZCE11 ⊕ 	ZCMV29M12 + ZCE02 ⊕ 	ZCMV29M12 + ZCE026 ⊕ 	ZCMV29M12 + ZCE24 ⊕ 	ZCMV29M12 + ZCEF0 ⊕ 
Contact operation	 (A) = cam displacement (P) = positive opening point ⊕ NC contact with positive opening operation						

Complementary characteristics not shown under general characteristics (see page 52)

Switch actuation	On end		By 30° cam		On end
Type of actuation					
Maximum actuation speed	0.5 m/s				
Mechanical durability	10 million operating cycles				
Nominal force or torque	For tripping	8.5 N	7 N	2.5 N	8.5 N
	For positive opening	42.5 N	35 N	12.5 N	42.5 N
Connection	M12 connector				

(1) For use at -40 °C.
(2) Nitrile for indoor use.
(3) Value taken with actuation by moving part at 100 mm from the fixing.

Plunger (fixing by the head)	Rotary (fixing by the body)	Multi-directional
------------------------------	-----------------------------	-------------------



M16 with metal end plunger with elastomer boot	M12 with steel roller plunger	Thermoplastic roller lever	Thermoplastic roller lever -40 °C (1)	Steel roller lever	Roller lever with ball bearing mounted roller	Variable length thermoplastic roller lever	"Cat's whisker" (3)
--	-------------------------------	----------------------------	---------------------------------------	--------------------	---	--	---------------------

ZCMV21M12 + ZCEG1 ⊕ 	ZCMV21v + ZCEF2 ⊕ 	ZCMV21M12 + ZCE01 + ZCY15 ⊕ 	ZCMV21M12 + ZCE016 + ZCY15 ⊕ 	ZCMV21M12 + ZCE01 + ZCY16 ⊕ 	ZCMV21M12 + ZCE01 + ZCY17 ⊕ 	ZCMV21M12 + ZCE01 + ZCY45 ⊕ 	ZCMV21M12 + ZCE06
ZCMV25M12 + ZCEG1 ⊕ 	ZCMV25M12 + ZCEF2 ⊕ 	ZCMV25M12 + ZCE01 + ZCY15 ⊕ 	ZCMV25M12 + ZCE016 + ZCY15 ⊕ 	ZCMV25M12 + ZCE01 + ZCY16 ⊕ 	ZCMV25M12 + ZCE01 + ZCY17 ⊕ 	ZCMV25M12 + ZCE01 + ZCY45 ⊕ 	ZCMV25M12 + ZCE06
ZCMV29M12 + ZCEG1 ⊕ 	ZCMV29M12 + ZCEF2 ⊕ 	ZCMV29M12 + ZCE01 + ZCY15 ⊕ 	ZCMV29M12 + ZCE016 + ZCY15 ⊕ 	ZCMV29M12 + ZCE01 + ZCY16 ⊕ 	ZCMV29M12 + ZCE01 + ZCY17 ⊕ 	ZCMV29M12 + ZCE01 + ZCY45 ⊕ 	ZCMV29M12 + ZCE06

■ closed
□ open

(A) = cam displacement
(P) = positive opening point

⊕ NC contact with positive opening operation

On end	By 30° cam	By any moving part
0.5 m/s	0.1 m/s	1.5 m/s
10 million operating cycles		10 million
8.5 N	7 N.m	0.1 N.m
42.5 N	35 N.m	0.5 N.m
		5 million
		0.1 N.m
		0.5 N.m
		–

M12 connector

Limit switches

XC Standard range

Miniature design, metal, XCMV
Modular units for mobile equipment



Type of operator	Metal end plunger	Metal end plunger - 40 °C (1)	Metal end plunger with elastomer boot (2)	Steel roller plunger	Steel roller plunger - 40 °C (1)	Retractable steel roller lever plunger	M12 with metal end plunger
------------------	-------------------	-------------------------------	---	----------------------	----------------------------------	--	----------------------------

References of modular units (pre-cabled body and removable terminal block)

4-pole 2 NC + 2 NO snap action	ZCMV41L03 + ZCE10	ZCMV41L03 + ZCE106	ZCMV41L03 + ZCE11	ZCMV41L03 + ZCE02	ZCMV41L03 + ZCE026	ZCMV41L03 + ZCE24	ZCMV41L03 + ZCEF0

Contact operation		(A) = cam displacement (P) = positive opening point			⊕ NC contact with positive opening operation		
-------------------	--	--	--	--	--	--	--

Complementary characteristics not shown under general characteristics (see page 52)

Switch actuation	On end	By 30° cam	On end		
Type of actuation					
Maximum actuation speed	0.5 m/s				
Mechanical durability	10 million operating cycles				
Nominal force or torque	For tripping	8.5 N	7 N	2.5 N	8.5 N
	For positive opening	42.5 N	35 N	12.5 N	42.5 N
Connection	PvR cable, length 30 cm				

(1) For use at -40 °C.
(2) Nitrile for indoor use.
(3) Value taken with actuation by moving part at 100 mm from the fixing.

Plunger (fixing by the head)	Rotary (fixing by the body)	Multi-directional
------------------------------	-----------------------------	-------------------



M16 with metal end plunger with elastomer boot	M12 with steel roller plunger	Thermoplastic roller lever	Thermoplastic roller lever -40 °C (1)	Steel roller lever	Roller lever with ball bearing mounted roller	Variable length thermoplastic roller lever	"Cat's whisker" (3)
--	-------------------------------	----------------------------	---------------------------------------	--------------------	---	--	---------------------

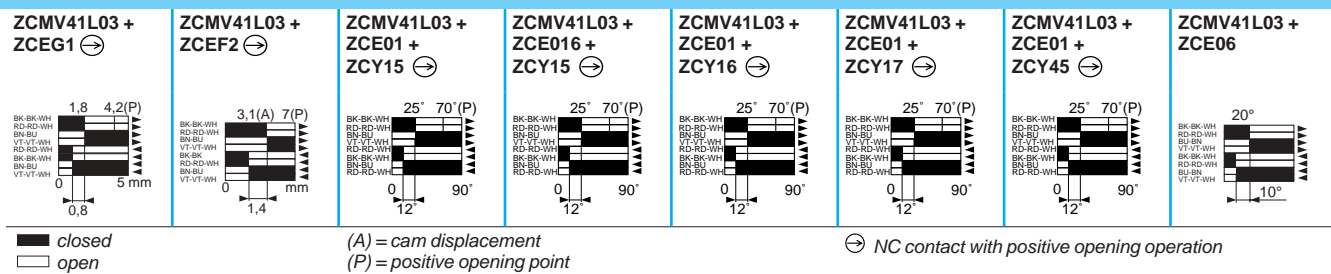

On end	By 30° cam	By any moving part
0.5 m/s	0.1 m/s	1.5 m/s
10 million operating cycles		10 million
8.5 N	7 N.m	0.1 N.m
42.5 N	35 N.m	0.5 N.m

PvR cable, length 30 cm

Limit switches

XC Standard range

Miniature design, metal, XCMV

Complete units for mobile equipment

Dimensions

Switches with Deutsch DT04-4P connector

XCMV2115D44, XCMV2515D44

XCMV2110D44, XCMV2510D44

XCMV2102D44, XCMV2502D44

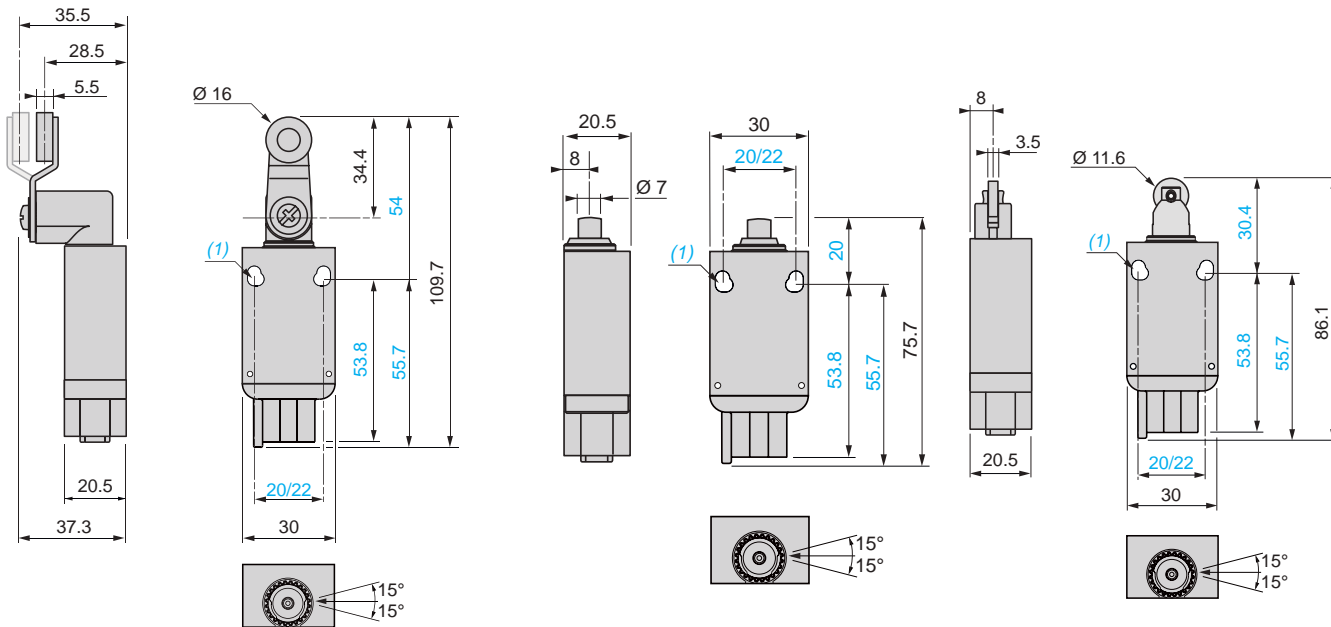

Switches with AMP Superseal 1.5 connector

XCMD2115AM4, XCMD2515AM4

XCMD2110AM4, XCMD2510AM4

XCMD2102AM4, XCMD2502AM4

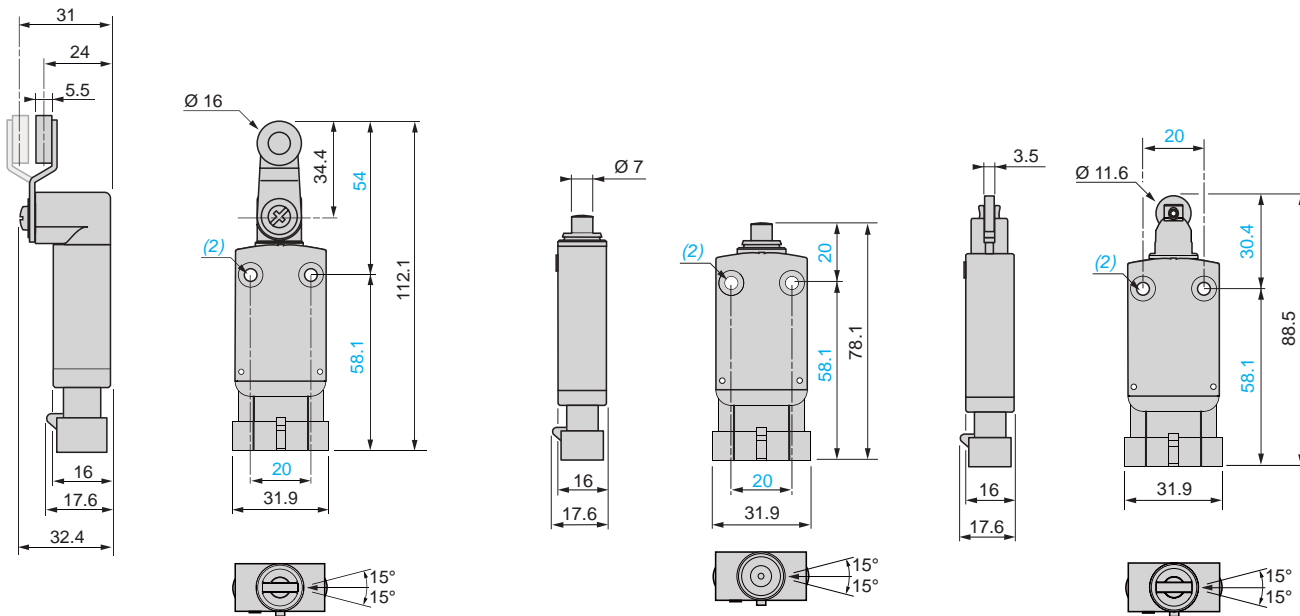

(1) 2 elongated fixing holes $\varnothing 4.3 \times 6.3$ mm on 22 mm centres, 2 elongated fixing holes $\varnothing 4.3$ on 20 mm centres.
 (2) 2 fixing holes $\varnothing 4.2$ mm, counterbored $\varnothing 8$ mm by 4 mm deep.

Dimensions (continued)

Switches with M12 connector

XCMV2115M12, XCMV2515M12

XCMV2110M12, XCMV2510M12

XCMV2102M12, XCMV2502M12

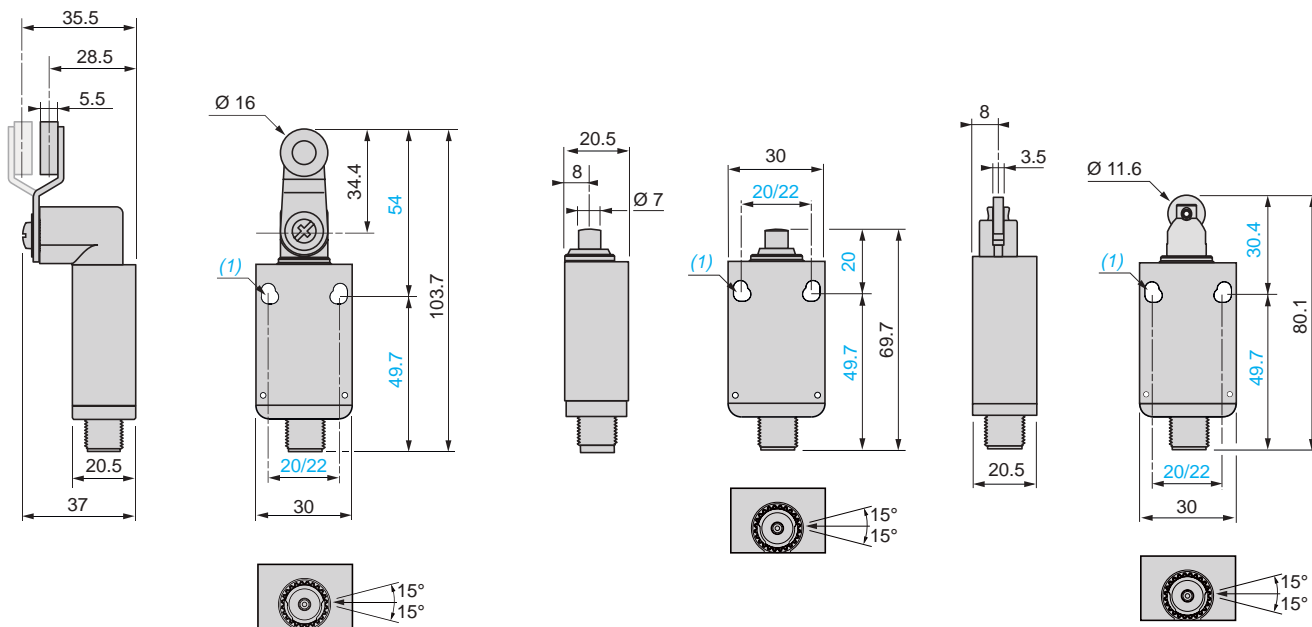

(1) 2 elongated fixing holes $\varnothing 4.3 \times 6.3$ mm on 22 mm centres, 2 elongated fixing holes $\varnothing 4.3$ on 20 mm centres.

Connections

Male AMP Superseal 1.5 connector

XCMV2●●●AM4

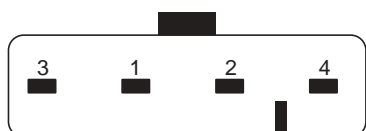

1 - 2 = NC
3 - 4 = NO

Male Deutsch DT04-4P connector

XCMV2●●●D44

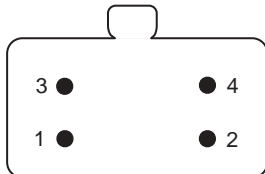

1 - 2 = NC
3 - 4 = NO

Male M12 connector

XCMV2●●●M12

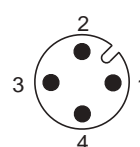

1 - 2 = NC
3 - 4 = NO

Limit switches

XC Standard range

Miniature design, metal, XCMV

Modular units for mobile equipment

Dimensions of bodies

ZCMV2•D44

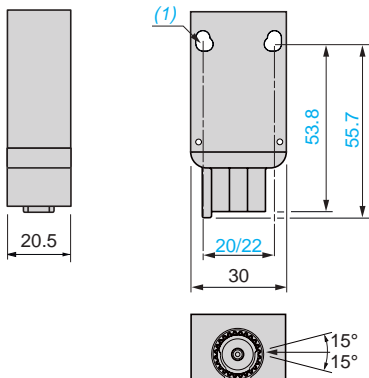

ZCMD2•AM4

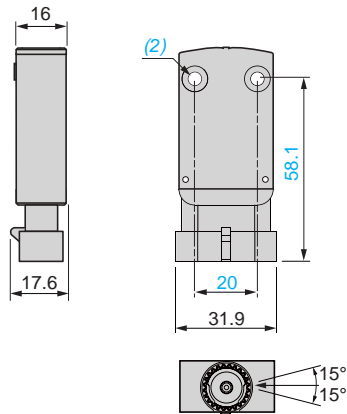

ZCMV2•M12

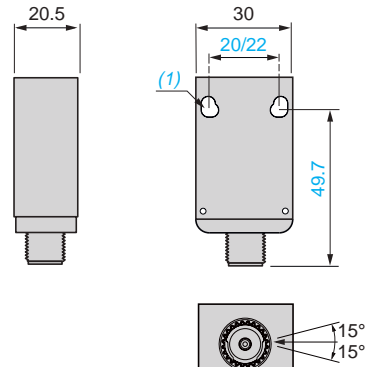

ZCMV41L03

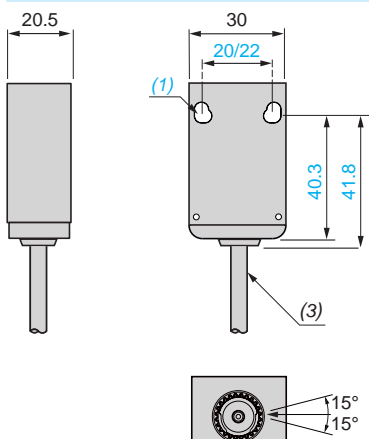

Mounting: distance required for connection

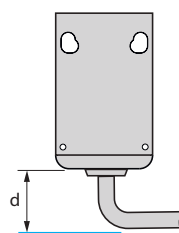

d: min. 20 mm

Dimensions of heads

ZCE106, ZCE10

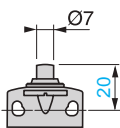

ZCE11

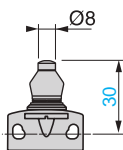

ZCE02, ZCE026

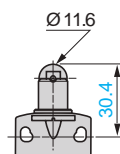

ZCE24

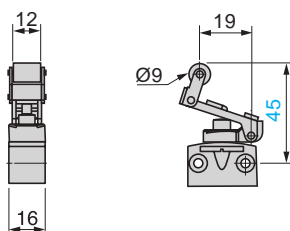

(1) 2 elongated fixing holes $\varnothing 4.3 \times 6.3$ mm on 22 mm centres, 2 elongated fixing holes $\varnothing 4.3$ on 20 mm centres.

(2) 2 fixing holes $\varnothing 4.2$ mm, counterbored $\varnothing 8$ mm by 4 mm deep.

(3) External diameter of cable 6.4 mm.

Limit switches

XC Standard range

Miniature design, metal, XCMV

Modular units for mobile equipment

Dimensions of heads (continued)

ZCEF0

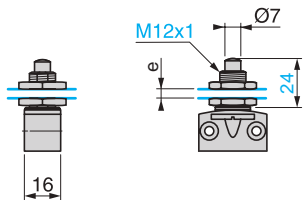

ZCEG1

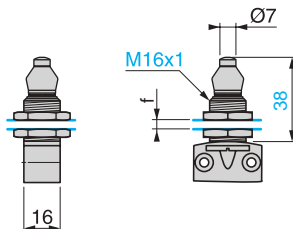

ZCEF2

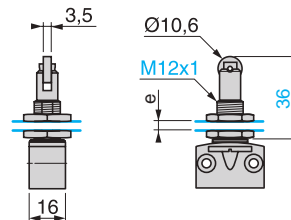

ZCE01 + ZCY15, ZCE01 + ZCY16
or ZCE01 + ZCY17

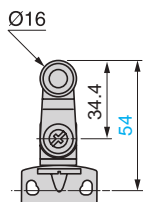

ZCE01 + ZCY45

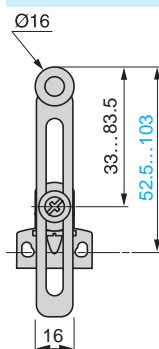

ZCE06

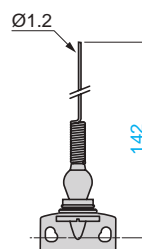

e: 8 mm max., panel cut-out Ø 12.5 mm, fixing nut thickness 3.5 mm.
f: 8 mm max., panel cut-out Ø 16.5 mm, fixing nut thickness 3.5 mm.

Limit switches

XC Basic range

Miniature design, plastic, XCMH

Pre-cabled

Complete units
pre-cabled

□ With head for linear movement (plunger), lateral or axial cable output



Pages 70 et 71

□ With head for rotary movement (lever), lateral or axial cable output

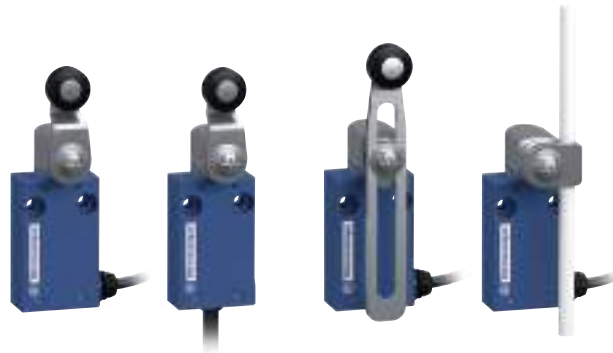

Page 71

□ With head for multi-directional movement, lateral cable output



Page 72

Environment characteristics		
Conformity to standards	Products	CE, IEC 60947-5-1, EN 60947-5-1, UL 508, CSA C22-2 n° 14
	Machine assemblies	IEC 60204-1, EN 60204-1
Product certifications		cULus, CCC, UKCA
Protective treatment	Standard version	"TC"
Ambient air temperature	For operation	- 25...+ 70 °C
	For storage	- 40...+ 70 °C
Vibration resistance	Conforming to IEC 60068-2-6	5 gn (10...500 Hz)
Shock resistance	Conforming to IEC 60068-2-27	25 gn (18 ms)
Electric shock protection		Class II conforming to IEC 61140 and NF C 20-030
Degree of protection		IP 66, IP67 conforming to IEC 60529 IK 04 conforming to IEC 50102
Materials	Bodies	Plastic
	Heads	Zamak
Contact block characteristics		
Rated operational characteristics		~ AC-15 ; C300 (Ue = 240 V, Ie = 0.75 A) ; Ith = 3 A
		⎓ DC-13 ; R300 (Ue = 250 V, Ie = 0.1 A), conforming to IEC 60947-5-1 Appendix C, EN 60947-5-1
Rated insulation voltage		Ui = 300 V degree of pollution 3 conforming to IEC 60947-1 Ui = 300 V conforming to UL 508, CSA C22-2 n° 14
Rated impulse withstand voltage		U imp = 4 kV conforming to IEC 60947-1, IEC 60664
Short-circuit protection		6 A cartridge fuse type gG (gl)

Limit switches

XC Basic range

Miniature design, plastic, XCMH

Pre-cabled



Type of operator	Metal end plunger		Metal end plunger with silicone boot (1)	Steel roller plunger for lateral cam approach		Steel roller plunger for traverse cam approach	Thermoplastic roller lever plunger, horizontal actuation in 1 direction
Cable output	Lateral	Axial	Lateral	Lateral	Axial	Lateral	Lateral

References								
<p>2-pole NC + NO snap action</p>	XCMH2110L1	XCMH2110LA1	XCMH211AL05	XCMH2102L1	XCMH2102LA1	XCMH2103L1	XCMH2121L1	
	XCMH2110L2		XCMH211AL1	XCMH2102L2		XCMH2103L2		
	XCMH2110L3			XCMH2102L3		XCMH2103L3	XCMH2121L5	
				XCMH2102L5		XCMH2103L5		
				XCMH2102L6		XCMH2103L8		
				XCMH2102L7				
				XCMH2102L8				
				XCMH2102L9				
	<p>2-pole NC + NC snap action</p>	XCMH2910L1			XCMH2902L1		XCMH2903L1	
		XCMH2910L2			XCMH2902L5			
XCMH2910L3								
	<p>1,8 4,2(P) 0,8 5mm</p>	<p>1,8 4,2(P) 0,8 5mm</p>	<p>1,8 4,2(P) 0,8 5mm</p>	<p>3,1(A) 7(P) 1,4 mm</p>	<p>3,1(A) 7(P) 1,4 mm</p>	<p>3,1(A) 7(P) 1,4 mm</p>	<p>65(A) 14(P) 2,8 mm</p>	
Weight (kg)	0.5 m cable (L05)	–	0.055	–	–	–	–	
	1 m cable (L1)	0.064	0.069	0.070	0.070	0.070	0.077	
	2 m cable (L2)	0.092	–	–	0.099	–	0.106	
	3 m cable (L3)	0.120	–	–	0.127	–	–	
	5 m cable (L5)	–	–	–	0.184	–	0.191	
	6 m cable (L6)	–	–	–	0.212	–	–	
	7 m cable (L7)	–	–	–	0.240	–	–	
	8 m cable (L8)	–	–	–	0.269	–	–	
	9 m cable (L9)	–	–	–	0.297	–	–	

Contact operation closed (A) = cam displacement NC contact with positive opening operation
 open (P) = positive opening point

Complementary characteristics not shown under general characteristics (see page 69)				
Switch actuation	On end		By 30° cam	
Type of actuation				
Maximum actuation speed	0.5 m/s	1.5 m/s	0.5 m/s	0.5 m/s
Mechanical durability	5 million operating cycles			
Minimum force or torque	For tripping	8.5 N.m	0.1 N.m	7 N.m
	For positive opening	42.5 N.m	0.5 N.m	35 N.m
Cabling	PvR cable, 4 x 0.34 mm ²			

(1) Silicone boot for outdoor use.

Limit switches

XC Basic range
Miniature design, plastic, XCMH
Pre-cabled

Type of head	Plunger (fixing by the body)	Plunger (fixing by the head)	Rotary (fixing by the body)			
--------------	------------------------------	------------------------------	-----------------------------	--	--	--



Type of operator	Thermoplastic roller lever plunger, horizontal actuation in 1 direction Head oriented at 270°	M12 with metal end plunger	M12 with steel roller plunger for lateral cam approach	Thermoplastic roller lever		Thermoplastic roller lever Head oriented at 180°
Cable output	Lateral	Lateral	Lateral	Lateral	Axial	Lateral

References

	2-pole NC + NO snap action	XCMH2121L1R0 	XCMH21F0L1 	XCMH21F2L1 	XCMH2115L1 	XCMH2115LA1 	XCMH2115L1L0
			XCMH21F0L2 	XCMH21F2L2 	XCMH2115L2 		XCMH2115L2L0
					XCMH2115L3 		XCMH2115L3L0
					XCMH2115L8 		
Weight (kg)	1 m cable (L1) 2 m cable (L2) 3 m cable (L3) 8 m cable (L8)	0.077 – – –	0.081 0.110 – –	0.091 0.120 – –	0.106 0.134 0.163 0.304	0.106 – – –	0.106 0.134 0.163 –

Contact operation closed (A) = cam displacement NC contact with positive opening operation
 open (P) = positive opening point

Complementary characteristics not shown under general characteristics (see page 69)





Switch actuation	By 30° cam	On end	By 30° cam°			
Type of actuation						
Maximum actuation speed	0.5 m/s	0.5 m/s	0.1 m/s	0.1 m/s	1.5 m/s	
Mechanical durability	5 million operating cycles					
Minimum force or torque	For tripping	2.5 N.m	8.5 N.m	7 N.m	0.1 N.m	0.1 N.m
	For positive opening	12.5 N.m	42.5 N.m	35 N.m	0.5 N.m	0.5 N.m
Cabling	PvR cable, 4 x 0.34 mm ²					

Limit switches



XC Basic range

Miniature design, plastic, XCMH

Pre-cabled

Type of head	Rotary (fixing by the body)	Multi-directional
		
		
		

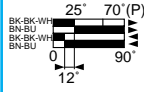
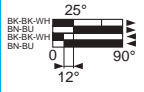
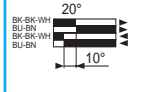
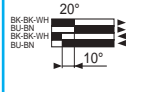
Type of operator	Variable length thermoplastic roller lever	Round thermoplastic rod lever, Ø 6 mm (1)	Spring lever with thermoplastic end (1)	"Cat's whisker" (1)
Cable output	Lateral	Lateral	Lateral	Lateral

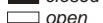
References					
	2-pole NC + NO snap action	XCMH2145L1 ⊖	XCMH2159L1	XCMH2107L1	XCMH2106L1
		XCMH2145L2 ⊖	XCMH2159L2	XCMH2107L2	XCMH2106L2
				XCMH2107L3	
					
Weight (kg)	1 m cable (L1)	0.115	0.070	0.079	0.068
	2 m cable (L2)	0.144	0.099	0.107	0.096
	3 m cable (L3)	–	–	0.136	–
Contact operation	 closed  open	(A) = cam displacement (P) = positive opening point	⊖ NC contact with positive opening operation		

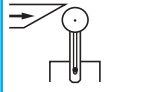
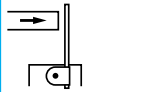
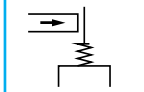
Complementary characteristics not shown under general characteristics (see page 69)				
Switch actuation		By 30° cam	By any moving part	
Type of actuation				
Maximum actuation speed		1.5 m/s	1 m/s	1 m/s (any direction)
Mechanical durability		5 million operating cycles		
Minimum force or torque	For tripping	0.1 N.m	0.1 N.m	0.1 N.m
	For positive opening	0.5 N.m	–	–
Cablings		PvR cable, 4 x 0.34 mm ²		

(1) Value taken with actuation by moving part at 100 mm from the fixing.

Limit switches

XC Basic range

Miniature design, plastic, XCMH

Pre-cabled

Dimensions

XCMH2110L1, XCMH2110L2, XCMH2110L3,
XCMH2910L1, XCMH2910L2 and XCMH2910L3

XCMH2110LA1

XCMH211AL05 and XCMH211AL1

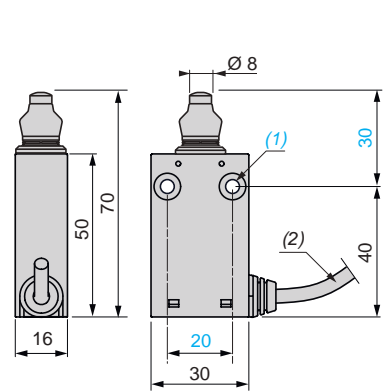
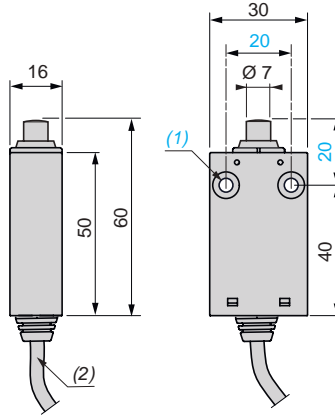
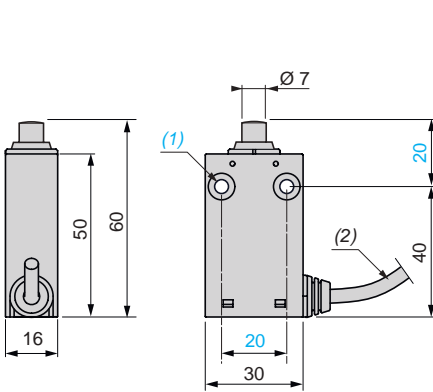

XCMH2102L1, XCMH2102L2, XCMH2102L3,
XCMH2102L5, XCMH2102L6, XCMH2102L7,
XCMH2102L8, XCMH2102L9, XCMH2902L1
and XCMH2902L5

XCMH2102LA1

XCMH2103L1, XCMH2103L2,
XCMH2103L3, XCMH2103L5
and XCMH2103L8

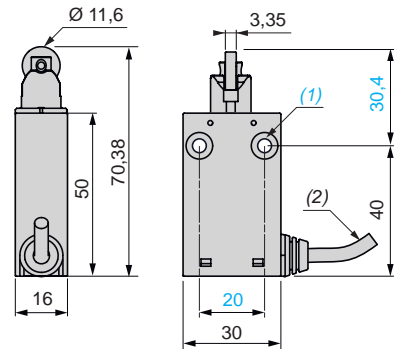
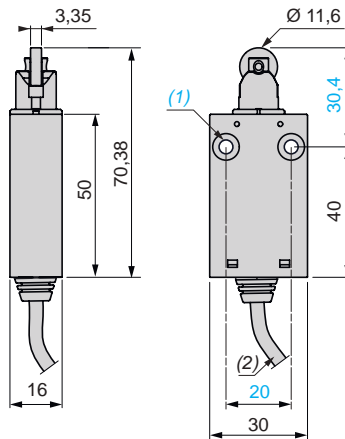
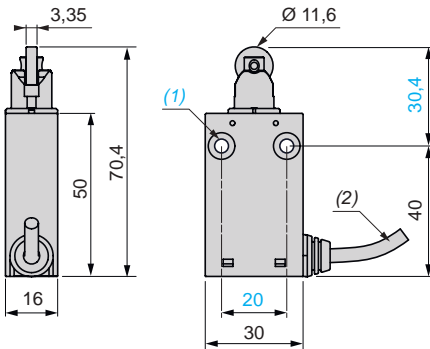

XCMH2121L1, XCMH2121L2 and XCMH2121L5

XCMH2121L1R0

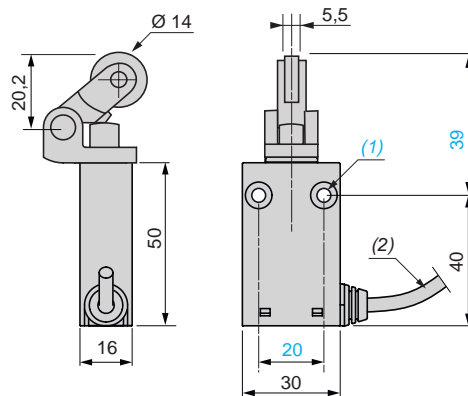
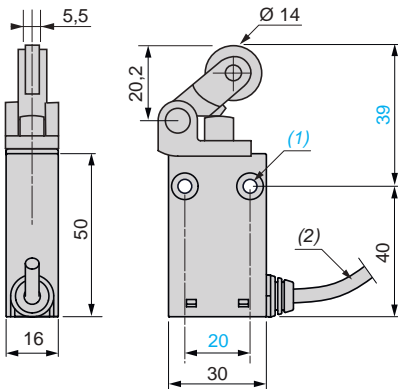

(1) 2 fixing holes Ø 4.2 mm, counterbored Ø 8 mm by 4 mm deep.

(2) External diameter 4.2 mm.

Limit switches

XC Basic range

Miniature design, plastic, XCMH

Pre-cabled

Dimensions (continued)

XCMH21F0L1 and XCMH21F0L2

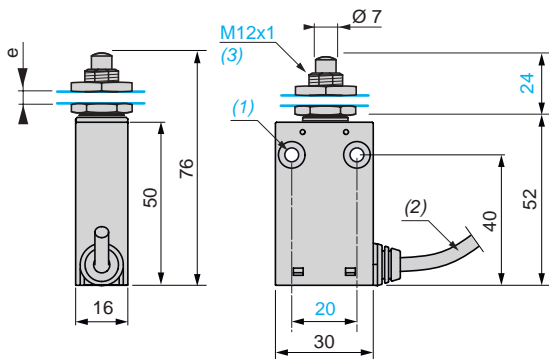

e: 8 mm max, panel cut-out Ø 12.5 mm. Fixing nut thickness 3.5 mm.

XCMH21F2L1 and XCMH21F2L2

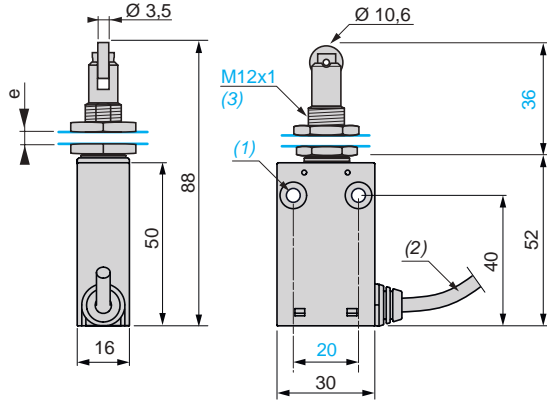

e: 8 mm max, panel cut-out Ø 12.5 mm. Fixing nut thickness 3.5 mm.

XCMH2115L1, XCMH2115L2, XCMH2115L5 and XCMH2115L8

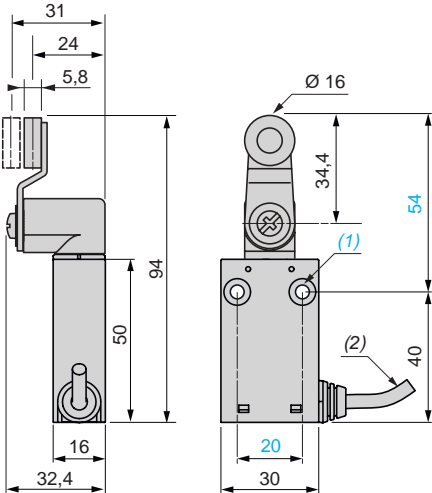

XCMH2115LA1

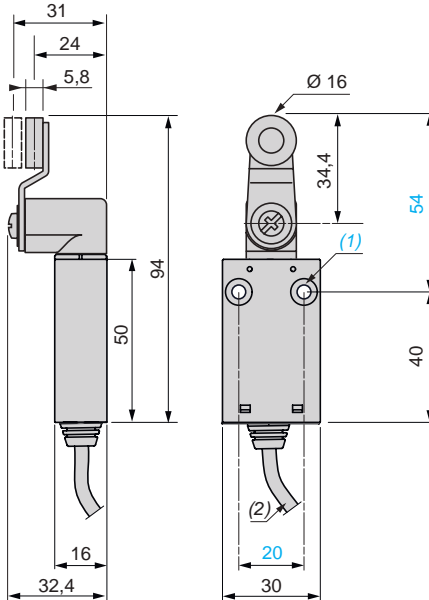

XCMH2115L1L0, XCMH2115L2L0 and XCMH2115L3L0

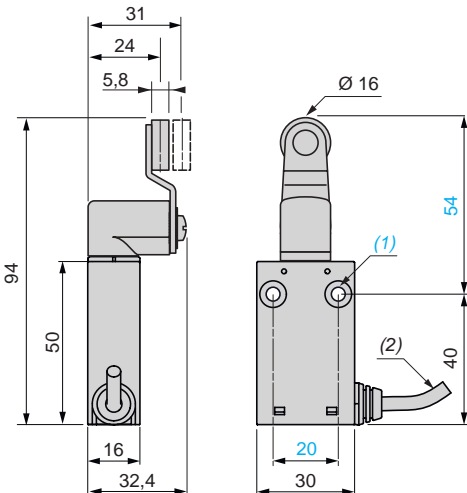

(1) 2 fixing holes Ø 4.2 mm, counterbored Ø 8 mm by 4 mm deep.

(2) External diameter 4.2 mm.

(3) Fixing nut thickness 3.5 mm.

Limit switches

XC Basic range

Miniature design, plastic, XCMH

Pre-cabled

Dimensions (continued)

XCMH2145L1 and XCMH2145L2

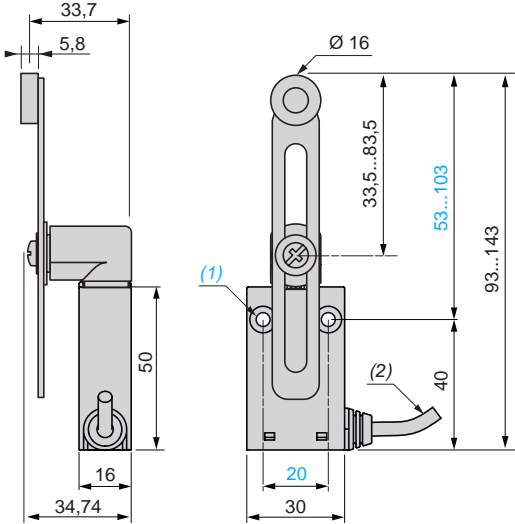

XCMH2159L1 and XCMH2159L2

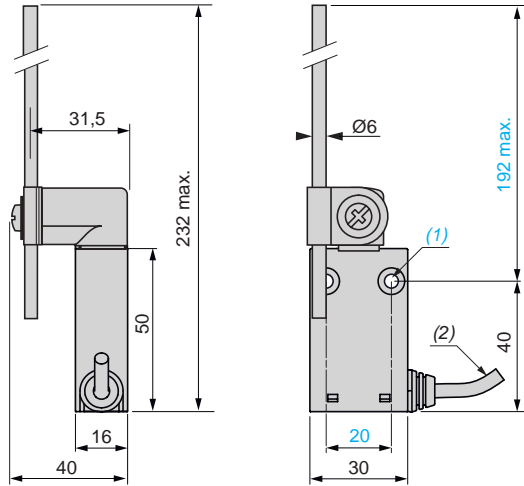

XCMH2107L1, XCMH2107L2 and XCMH2107L3

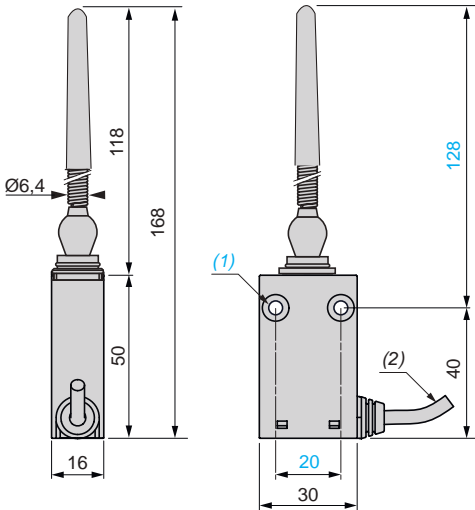

XCMH2106L1 and XCMH2106L2

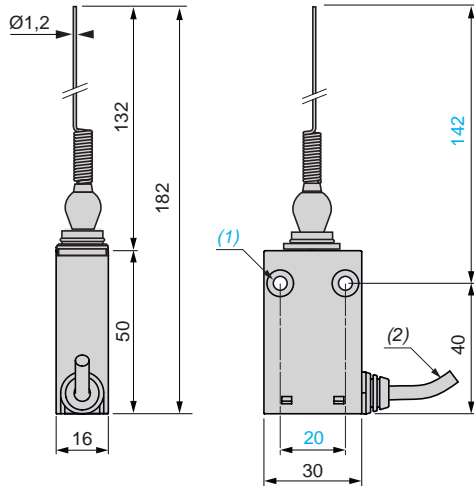

Mounting: distance required for connection

Limit switches with cable lateral output

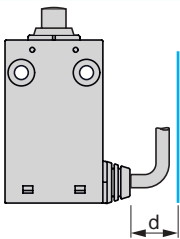

Limit switches with cable axial output

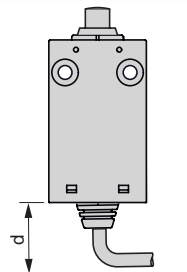

d: min. 15 mm.

(1) 2 fixing holes Ø 4.2 mm, counterbored Ø 8 mm by 4 mm deep.

(2) External diameter 4.2 mm.

Limit switches

XC Standard range

Compact design, plastic, XCKP and XCKT

Compact design, metal, XCKD

■ XCKP, XCKD

with 1 cable entry

Conforming to CENELEC EN 50047

□ With head for linear movement (plunger). Fixing by the head or by the body

XCKD

XCKP



Pages 84 and 88

Pages 78 and 82

□ With head for rotary movement (lever) or multi-directional. Fixing by the body

XCKD

XCKP



Pages 85 and 89

Pages 79 and 83

■ XCKT

with 2 cable entries

Tripping/resetting points and fixing centres conform to CENELEC EN 50047

□ With head for linear movement (plunger). Fixing by the head or by the body

XCKT

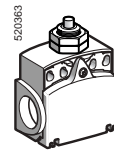
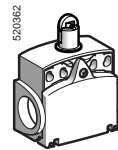
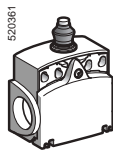

Page 90

□ With head for rotary movement (lever) or multi-directional. Fixing by the body

XCKT

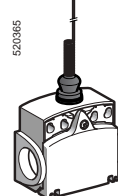
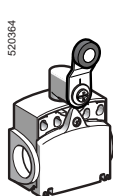

Page 90

Environment characteristics

Conformity to standards	Products	IEC 60947-5-1, EN 60947-5-1, UL 508, CSA C22-2 n° 14
	Machine assemblies	IEC 60204-1, EN 60204-1
Product certifications		UL, CSA, CCC
Protective treatment	Standard version	"TC"
Ambient air temperature	For operation	- 25...+ 70°C (- 40...+ 70 °C with ZCE106, ZCE026 and ZCE016 heads)
	For storage	- 40...+ 70°C
Vibration resistance	Conforming to IEC 60068-2-6	25 gn (10...500 Hz) except product with head ZCE24: 20 gn
Shock resistance	Conforming to IEC 60068-2-27	50 gn (11 ms) except head ZCE08: 15 gn (11 ms) and ZCE24: 30 gn (18 ms)
Electric shock protection		Class II conforming to IEC 61140 and NF C 20-030 for XCKP and XCKT Class I conforming to IEC 61140 and NF C 20-030 for XCKD
Degree of protection		IP 66 and IP 67 conforming to IEC 60529; IK 04 conforming to IEC 62262 for XCKP and XCKT, IK 06 conforming to IEC 62262 for XCKD
Repeat accuracy		0.1 mm on the tripping points, with 1 million operating cycles for head with end plunger
Cable entry or connector	Depending on model	Either tapped entry for n° 11 or n° 13 cable gland, tapped ISO M16 x 1.5 or ISO M20 x 1.5, tapped 1/2" NPT or PF 1/2 (G1/2) or M12 connector
Materials		XCKD Zamak bodies and heads, XCKP and XCKT plastic bodies, Zamak heads

Contact block characteristics		
Rated operational characteristics	XE2●P	~ AC-15; A300 (Ue = 240 V, Ie = 3 A); Ithe = 10 A --- DC-13; Q300 (Ue = 250 V, Ie = 0.27 A), conforming to IEC 60947-5-1 Appendix A, EN 60947-5-1
	XE3●P	~ AC-15; B300 (Ue = 240 V, Ie = 1.5 A); Ithe = 6 A --- DC-13; R300 (Ue = 250 V, Ie = 0.1 A), conforming to IEC 60947-5-1 Appendix A, EN 60947-5-1
Rated insulation voltage	XE2●P	Ui = 500 V degree of pollution 3 conforming to IEC 60947-1 Ui = 300 V conforming to UL 508, CSA C22-2 n° 14
	XE3●P	Ui = 400 V degree of pollution 3 conforming to IEC 60947-1 Ui = 300 V conforming to UL 508, CSA C22-2 n° 14
Rated impulse withstand voltage	XE2●P	U imp = 6 kV conforming to IEC 60947-1, IEC 60664
	XE3●P	U imp = 4 kV conforming to IEC 60947-1, IEC 60664
Positive operation (depending on model)		NC contacts with positive opening operation conforming to IEC 60947-5-1 Appendix K, EN 60947-5-1
Resistance across terminals		≤ 25 mΩ conforming to IEC 60255-7 category 3
Short-circuit protection	XE2●P	10 A cartridge fuse type gG (gl)
	XE3●P	6 A cartridge fuse type gG (gl)
Connection (screw clamp terminals)	XE2SP●151 and XE2SP2141	Clamping capacity, min: 1 x 0.34 mm ² , max: 2 x 1.5 mm ²
	XE2NP21●1 and XE2NP31●1	Clamping capacity, min: 1 x 0.5 mm ² , max: 2 x 2.5 mm ²
	XE3NP and XE3SP	Clamping capacity, min: 1 x 0.34 mm ² , max: 1 x 1 mm ² or 2 x 0.75 mm ²
Minimum actuation speed (for head with end plunger)		XE2SP●151, XE2SP2141 and XE3SP: 0.01 m/minute
		XE2NP21●1, XE2NP31●1 and XE3NP: 6 m/minute
Electrical durability		<ul style="list-style-type: none"> ■ Conforming to IEC 60947-5-1 Appendix C ■ Utilisation categories AC-15 and DC-13 ■ Maximum operating rate: 3600 operating cycles/hour ■ Load factor: 0.5

AC supply
50/60 Hz ~
mm. inductive circuit

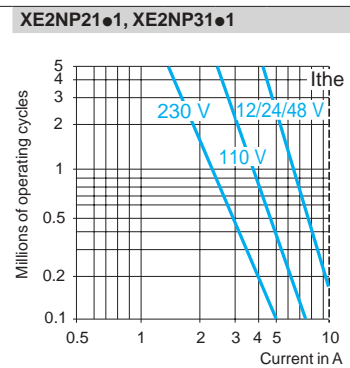
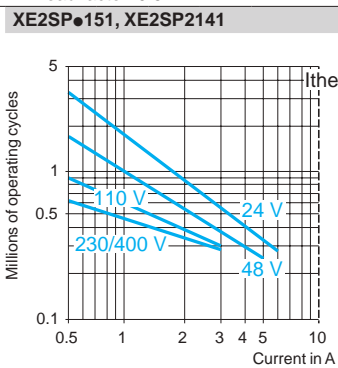

DC supply ---

Power broken in W for 5 million operating cycles.

Voltage V	24	48	120
mm. W	10	7	4

Power broken in W for 5 million operating cycles.

Voltage V	24	48	120
mm. W	13	9	7

For XE2SP●151 on ~ or ---, NC and NO contacts simultaneously loaded to the values shown with reverse polarity.

AC supply
50/60 Hz ~
mm. inductive circuit

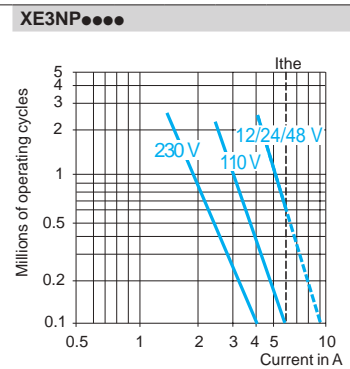
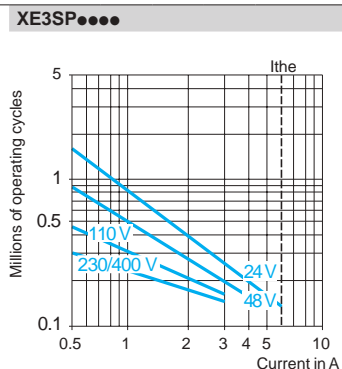

DC supply ---

Power broken in W for 5 million operating cycles.

Voltage V	24	48	120
mm. W	3	2	1

Power broken in W for 5 million operating cycles.

Voltage V	24	48	120
mm. W	4	3	2

Limit switches

XC Standard range

Compact design, plastic, XCKP
Complete switches with 1 cable entry

Type of head	Plunger (fixing by the body)					
	Form B (1)		Form C (1)		Form E (1)	
Type of operator	Metal end plunger	Metal end plunger with elastomer boot	Steel roller plunger	Thermoplastic roller lever plunger, horizontal actuation in 1 direction	Thermoplastic roller lever plunger, vertical actuation in 1 direction	Thermoplastic roller lever plunger, horiz. or vert. actuation in 1 direction

References of complete switches with 1 ISO M16 x 1.5 cable entry (2)							
	2-pole NC + NO snap action (XE2SP2151)	XCKP2110P16 	XCKP2111P16 	XCKP2102P16 	XCKP2121P16 	XCKP2127P16 	XCKP2128P16
	2-pole NC + NO break before make, slow break (XE2NP2151)	XCKP2510P16 	XCKP2511P16 	XCKP2502P16 	XCKP2521P16 	XCKP2527P16 	XCKP2528P16
	2-pole NC + NC snap action (XE2SP2141)	ZCP29 + ZCPEP16 + ZCE10 	ZCP29 + ZCPEP16 + ZCE11 	ZCP29 + ZCPEP16 + ZCE02 	ZCP29 + ZCPEP16 + ZCE21 	ZCP29 + ZCPEP16 + ZCE27 	ZCP29 + ZCPEP16 + ZCE28
	2-pole NC + NC simultaneous, slow break (XE2NP2141)	ZCP27 + ZCPEP16 + ZCE10 	ZCP27 + ZCPEP16 + ZCE11 	ZCP27 + ZCPEP16 + ZCE02 	ZCP27 + ZCPEP16 + ZCE21 	ZCP27 + ZCPEP16 + ZCE27 	ZCP27 + ZCPEP16 + ZCE28
	3-pole NC + NC + NO snap action (XE3SP2141)	ZCP39 + ZCPEP16 + ZCE10 	ZCP39 + ZCPEP16 + ZCE11 	ZCP39 + ZCPEP16 + ZCE02 	ZCP39 + ZCPEP16 + ZCE21 	ZCP39 + ZCPEP16 + ZCE27 	ZCP39 + ZCPEP16 + ZCE28
	3-pole NC + NC + NO break before make, slow break (XE3NP2141)	ZCP37 + ZCPEP16 + ZCE10 	ZCP37 + ZCPEP16 + ZCE11 	ZCP37 + ZCPEP16 + ZCE02 	ZCP37 + ZCPEP16 + ZCE21 	ZCP37 + ZCPEP16 + ZCE27 	ZCP37 + ZCPEP16 + ZCE28
Weight (kg)		0.090	0.090	0.095	0.105	0.100	0.105

References of complete switches with 1 entry for n° 11 cable gland

For an entry tapped for a n° 11 cable gland, replace P16 in the reference by G11. Example: XCKP2110P16 becomes XCKP2110G11 or ZCPEP16 becomes ZCPEG11.

Contact operation	closed open	(A) (B) = cam displacement (P) = positive opening point	NC contact with positive opening operation
-------------------	----------------	--	--

Characteristics		On end	By 30° cam
Switch actuation		On end	By 30° cam
Type of actuation			
Maximum actuation speed		0.5 m/s	1 m/s
Mechanical durability (in millions of operating cycles)		15	10
Minimum force or torque	For tripping	15 N	12 N
	For positive opening	45 N	36 N
Cable entry (3)		1 entry tapped M16 x 1.5 mm for ISO cable gland, clamping capacity 4 to 8 mm	

(1) Form conforming to EN 50047, see page 24.

(2) Switches with gold contacts or eyelet type connections: please consult our Customer Care Centre.

Limit switches

XC Standard range
Compact design, plastic, XCKP
Complete switches with 1 cable entry

Type of head	Plunger (fixing by the head)		Rotary (fixing by the body)				Multi-directional
	Form A (1)						
Type of operator	M18 with metal end plunger	M18 with steel roller plunger	Thermoplastic roller lever	Variable length thermoplastic roller lever	Thermoplastic roller lever, Ø 50 mm	Variable length thermoplastic roller lever, Ø 50 mm	"Cat's whisker" (2)

References of complete switches with 1 ISO M16 x 1.5 cable entry (3)

Reference	2-pole NC + NO snap action (XE2SP2151)	2-pole NC + NO break before make, slow break (XE2NP2151)	2-pole NC + NC snap action (XE2SP2141)	2-pole NC + NC simultaneous, slow break (XE2NP2141)	3-pole NC + NC + NO snap action (XE3SP2141)	3-pole NC + NC + NO break before make, slow break (XE3NP2141)	
	XCKP21H0P16	XCKP21H2P16	ZCP29 + ZCPEP16 + ZCEH0	ZCP27 + ZCPEP16 + ZCEH0	ZCP39 + ZCPEP16 + ZCEH0	ZCP37 + ZCPEP16 + ZCEH0	
	XCKP2118P16	XCKP2145P16	ZCP29 + ZCPEP16 + ZCE01 + ZCY18	ZCP27 + ZCPEP16 + ZCE01 + ZCY18	ZCP39 + ZCPEP16 + ZCE01 + ZCY45	ZCP37 + ZCPEP16 + ZCE01 + ZCY18	
	XCKP2139P16	XCKP2149P16	ZCP29 + ZCPEP16 + ZCE01 + ZCY39	ZCP27 + ZCPEP16 + ZCE01 + ZCY39	ZCP39 + ZCPEP16 + ZCE01 + ZCY49	ZCP37 + ZCPEP16 + ZCE01 + ZCY39	
	XCKP2106P16	XCKP2518P16	ZCP29 + ZCPEP16 + ZCE06	ZCP27 + ZCPEP16 + ZCE06	ZCP39 + ZCPEP16 + ZCE06	ZCP37 + ZCPEP16 + ZCE06	
Weight (kg)	0.130	0.130	0.135	0.145	0.145	0.155	0.085

References of complete switches with 1 entry for n° 11 cable gland

For an entry tapped for a n° 11 cable gland, replace P16 in the reference by G11. Example: XCKP21H0P16 becomes XCKP21H0G11 or ZCPEP16 becomes ZCPEG11.

Contact operation closed (A) = cam displacement NC contact with positive opening operation
 open (P) = positive opening point

Characteristics

Switch actuation	On end	By 30° cam	By any moving part
Type of actuation			
Maximum actuation speed	0.5 m/s	1.5 m/s	1 m/s (any direct.)
Mechanical durability	10 million operating cycles		5 million
Minimum force or torque	For tripping: 15 N For positive opening: 45 N	10 N 36 N	0.1 N.m 0.25 N.m -
Cable entry	1 entry tapped M16 x 1.5 mm for ISO cable gland, clamping capacity 4 to 8 mm		

(1) Form conforming to EN 50047, see page 24.

(2) Value taken with actuation by moving part at 100 mm from the fixing.

(3) Switches with gold contacts or eyelet type connections: please consult our Customer Care Centre.

Limit switches

XC Standard range

Compact design, plastic, XCKP

Complete switches with 1 cable entry

ZCP2● + ZCPEP16/ZCP3● + ZCPEP16

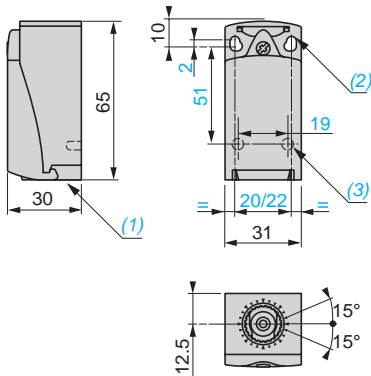

ZCE10

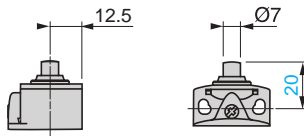

ZCE11

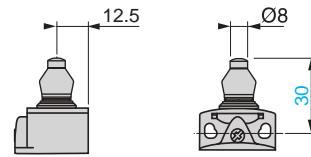

ZCE02

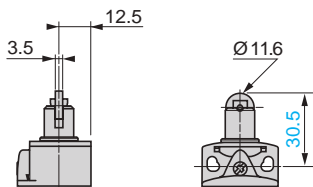

ZCE21

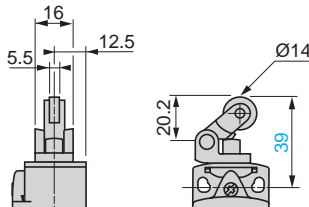

ZCE27

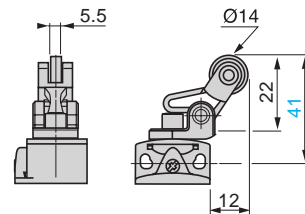

ZCE28

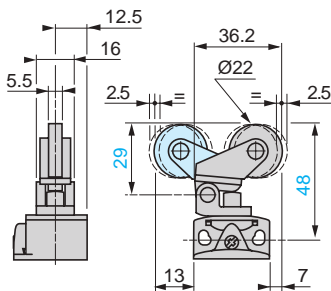

ZCEH0

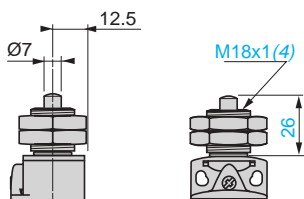

ZCEH2

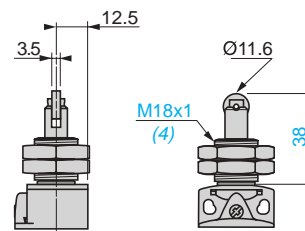

- (1) Tapped entry for ISO M16 x 1.5 or Pg 11 cable gland.
 (2) 2 elongated holes Ø 4.3 x 6.3 mm on 22 mm centres, 2 holes Ø 4.3 on 20 mm centres.
 (3) 2 x Ø 3 holes for support studs, depth 4 mm.
 (4) Fixing nut thickness 3.5 mm.

Limit switches

XC Standard range

Compact design, plastic, XCKP

Complete switches with 1 cable entry

ZCE01 + ZCY18

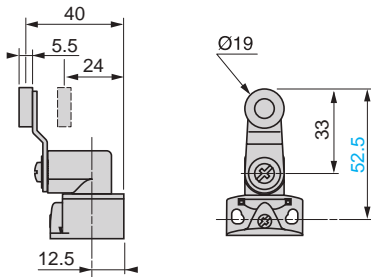

ZCE01 + ZCY45

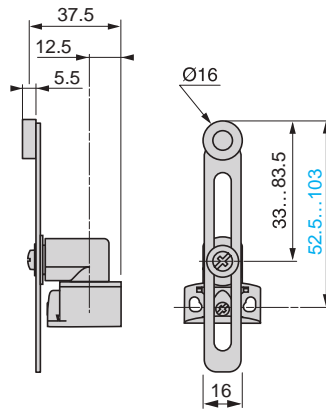

ZCE01 + ZCY39

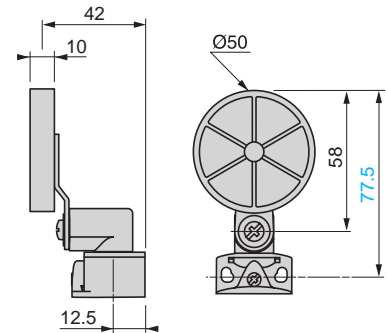

ZCE01 + ZCY49

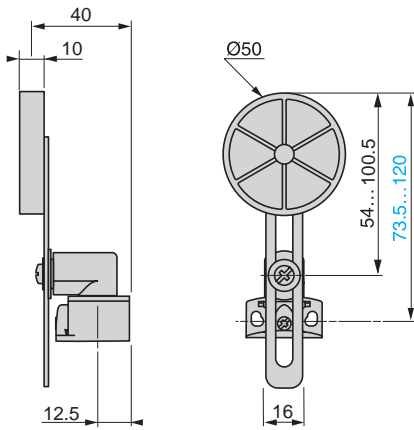



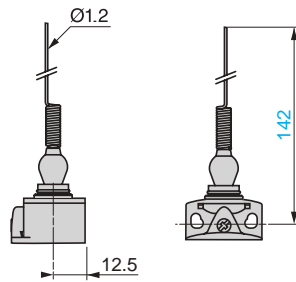









ZCE06



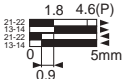
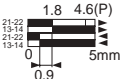
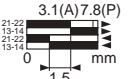
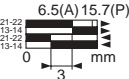
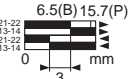
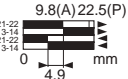

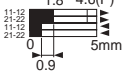
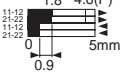
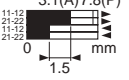
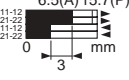
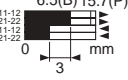
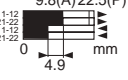
Limit switches

XC Standard range
Compact design, plastic, XCKP
M12 connector

Type of head	Plunger (fixing by the body)					
	Form B (1)		Form C (1)	Form E (1)		
						
Type of operator	Metal end plunger		Metal end plunger with elastomer boot (2)	Steel roller plunger	Thermoplastic roller lever plunger, horizontal actuation in 1 direction	Thermoplastic roller lever plunger, vertical actuation in 1 direction

References						
2-pole NC + NO snap action (XE2SP2151)	XCKP2110M12	XCKP2111M12	XCKP2102M12	XCKP2121M12	XCKP2127M12	XCKP2128M12
						
2-pole NC + NC snap action (XE2SP2141)	ZCP29M12 + ZCE10	ZCP29M12 + ZCE11	ZCP29M12 + ZCE02	ZCP29M12 + ZCE21	ZCP29M12 + ZCE27	ZCP29M12 + ZCE28
						
Weight (kg)	0.100	0.100	0.100	0.110	0.110	0.110
Contact operation	 closed  open		(A) (B) = cam displacement (P) = positive opening point		 NC contact with positive opening operation	

(1) Form conforming to EN 50047, see page 24.
(2) Nitrile for indoor use.

Characteristics			
Switch actuation	On end	By 30° cam	
Type of actuation			
Maximum actuation speed	0.5 m/s	1 m/s	
Mechanical durability (in millions of operating cycles)	15	10	15
Minimum force or torque	For tripping: 15 N For positive opening: 45 N	12 N 36 N	6 N 18 N
Connection	M12 connector, U _i = 250 V, I _e = 3 A maximum, I _{th} = 3 A		

Connections

M12 connector

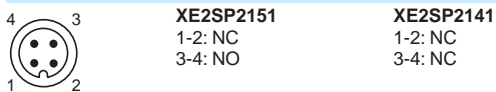

Dimensions

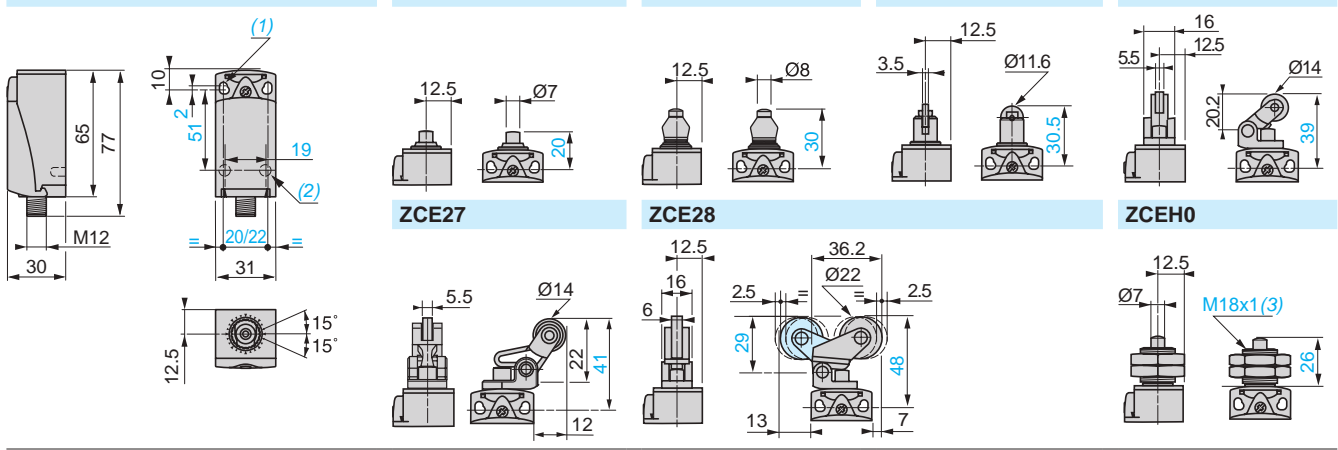

(1) 2 elongated holes Ø 4.3 x 6.3 mm on 22 mm centres, 2 holes Ø 4.3 on 20 mm centres.
(2) 2 x Ø 3 holes for support studs, depth 4 mm.
(3) Fixing nut thickness 3.5 mm.

Limit switches

XC Standard range
Compact design, plastic, XCKP
M12 connector

Type of head	Plunger (fixing by the head)		Rotary (fixing by the body)				Multi-directional
			Form A (1)				
Type of operator	M18 with metal end plunger	M18 with steel roller plunger	Thermoplastic roller lever	Variable length thermoplastic roller lever	Thermoplastic roller lever, Ø 50 mm	Variable length thermoplastic roller lever, Ø 50 mm	"Cat's whisker" (2)

References							
2-pole NC + NO snap action (XE2SP2151)	-	-	XCKP2118M12 	XCKP2145M12 	-	XCKP2149M12 	XCKP2106M12
2-pole NC + NC snap action (XE2SP2141)	ZCP29M12 + ZCEH0 	ZCP29M12 + ZCEH2 	ZCP29M12 + ZCE01 + ZCY18 	ZCP29M12 + ZCE01 + ZCY45 	ZCP29M12 + ZCE01 + ZCY39 	ZCP29M12 + ZCE01 + ZCY49 	ZCP29M12 + ZCE06
Weight (kg)	0.140	0.140	0.140	0.150	0.155	0.160	0.090
Contact operation	closed open		(A) = cam displacement (P) = positive opening point		NC contact with positive opening operation		
(1) Form conforming to EN 50047, see page 24. (2) Value taken with actuation by moving part at 100 mm from the fixing.							

Characteristics					
Switch actuation	On end	By 30° cam			By any moving part
Type of actuation					
Maximum actuation speed	0.5 m/s	1.5 m/s			1 m/s (any direct.)
Mechanical durability (in millions of operating cycles)	10				5
Minimum force or torque	For tripping	15 N	10 N	0.1 N.m	0.13 N.m
	For positive opening	45 N	36 N	0.25 N.m	-
Connection	M12 connector, Ui = 250 V, Ie = 3 A maximum, Ith = 3 A				

Dimensions				
ZCE01 + ZCY18	ZCE01 + ZCY45	ZCE01 + ZCY39	ZCE01 + ZCY49	ZCE06

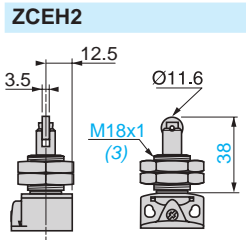
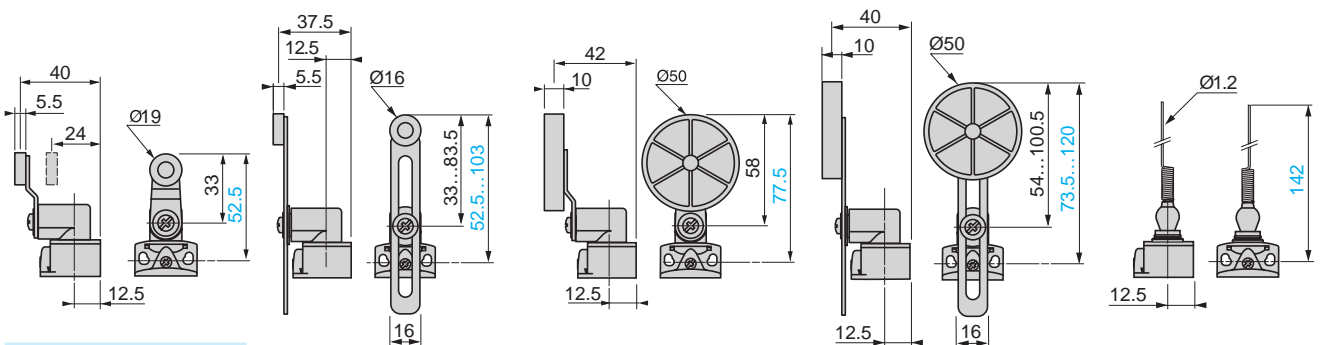

(3) Fixing nut thickness 3.5 mm.

Limit switches

XC Standard range

Compact design, metal, XCKD
Complete switches with 1 cable entry

Type of head	Plunger (fixing by the body)					
	Form B (1)		Form C (1)		Form E (1)	
Type of operator	Metal end plunger		Metal end plunger with elastomer boot (2)	Steel roller plunger	Thermoplastic roller lever plunger, horizontal actuation in 1 direction	Thermoplastic roller lever plunger, vertical actuation in 1 direction

References of complete switches with 1 ISO M16 x 1.5 cable entry (3)

	2-pole NC + NO snap action (XE2S P2151)	XCKD2110P16 ⊖	XCKD2111P16 ⊖	XCKD2102P16 ⊖	XCKD2121P16 ⊖	XCKD2127P16 ⊖	XCKD2128P16 ⊖
	2-pole NC + NO break before make, slow break (XE2N P2151)	XCKD2510P16 ⊖	XCKD2511P16 ⊖	XCKD2502P16 ⊖	XCKD2521P16 ⊖	XCKD2527P16 ⊖	XCKD2528P16 ⊖
	2-pole NC + NC snap action (XE2S P2141)	ZCD29 + ZCDEP16 + ZCE10 ⊖	ZCD29 + ZCDEP16 + ZCE11 ⊖	ZCD29 + ZCDEP16 + ZCE02 ⊖	ZCD29 + ZCDEP16 + ZCE21 ⊖	ZCD29 + ZCDEP16 + ZCE27 ⊖	ZCD29 + ZCDEP16 + ZCE28 ⊖
	2-pole NC + NC simultaneous, slow break (XE2N P2141)	ZCD27 + ZCDEP16 + ZCE10 ⊖	ZCD27 + ZCDEP16 + ZCE11 ⊖	ZCD27 + ZCDEP16 + ZCE02 ⊖	ZCD27 + ZCDEP16 + ZCE21 ⊖	ZCD27 + ZCDEP16 + ZCE27 ⊖	ZCD27 + ZCDEP16 + ZCE28 ⊖
	3-pole NC + NC + NO snap action (XE3S P2141)	ZCD39 + ZCDEP16 + ZCE10 ⊖	ZCD39 + ZCDEP16 + ZCE11 ⊖	ZCD39 + ZCDEP16 + ZCE02 ⊖	ZCD39 + ZCDEP16 + ZCE21 ⊖	ZCD39 + ZCDEP16 + ZCE27 ⊖	ZCD39 + ZCDEP16 + ZCE28 ⊖
	3-pole NC + NC + NO break before make, slow break (XE3N P2141)	ZCD37 + ZCDEP16 + ZCE10 ⊖	ZCD37 + ZCDEP16 + ZCE11 ⊖	ZCD37 + ZCDEP16 + ZCE02 ⊖	ZCD37 + ZCDEP16 + ZCE21 ⊖	ZCD37 + ZCDEP16 + ZCE27 ⊖	ZCD37 + ZCDEP16 + ZCE28 ⊖
Weight (kg)	0.180	0.180	0.185	0.195	0.190	0.195	0.195

References of complete switches with 1 entry for n° 11 cable gland

For an entry tapped for a n° 11 cable gland, replace P16 in the reference by G11. Example: XCKD2110P16 becomes XCKD2110G11 or ZCDEP16 becomes ZCDEG11.

Contact operation	closed open	(A) (B) = cam displacement (P) = positive opening point	NC contact with positive opening operation
-------------------	----------------	--	--

Characteristics

Switch actuation	On end	By 30° cam			
Type of actuation					
Maximum actuation speed	0.5 m/s		1 m/s		
Mechanical durability (in millions of operating cycles)	15		10		
Minimum force or torque	For tripping	15 N	12 N	6 N	
	For positive opening	45 N	36 N	18 N	
Cable entry	1 entry tapped M16 x 1.5 mm for ISO cable gland, clamping capacity 4 to 8 mm				

(1) Form conforming to EN 50047, see page 24.
 (2) Nitrile for indoor use.
 (3) Switches with gold contacts or eyelet type connections: please consult our Customer Care Centre.

Limit switches

XC Standard range
Compact design, metal, XCKD
Complete switches with 1 cable entry

Type of head	Plunger (fixing by the head)	Rotary (fixing by the body)					Multi-directional
		Form A (1)					
Type of operator	M18 with metal end plunger	M18 with steel roller plunger	Thermoplastic roller lever	Variable length thermoplastic roller lever	Thermoplastic roller lever, Ø 50 mm	Variable length thermoplastic roller lever, Ø 50 mm	"Cat's whisker" (2)

References of complete switches with 1 ISO M16 x 1.5 cable entry (3)

	2-pole NC + NO snap action (XE2S P2151)	XCKD21H0P16 	XCKD21H2P16 	XCKD2118P16 	XCKD2145P16 	XCKD2139P16 	XCKD2149P16 	XCKD2106P16
	2-pole NC + NO break before make, slow break (XE2N P2151)	-	XCKD25H2P16 	XCKD2518P16 	XCKD2545P16 	XCKD2539P16 	-	XCKD2506P16
	2-pole NC + NC snap action (XE2S P2141)	ZCD29 + ZCDEP16 + ZCEH0 	ZCD29 + ZCDEP16 + ZCEH2 	ZCD29 + ZCDEP16 + ZCE01 + ZCY18 	ZCD29 + ZCDEP16 + ZCE01 + ZCY45 	ZCD29 + ZCDEP16 + ZCE01 + ZCY39 	ZCD29 + ZCDEP16 + ZCE01 + ZCY49 	ZCD29 + ZCDEP16 + ZCE06
	2-pole NC + NC simultaneous, slow break (XE2N P2141)	ZCD27 + ZCDEP16 + ZCEH0 	ZCD27 + ZCDEP16 + ZCEH2 	ZCD27 + ZCDEP16 + ZCE01 + ZCY18 	ZCD27 + ZCDEP16 + ZCE01 + ZCY45 	ZCD27 + ZCDEP16 + ZCE01 + ZCY39 	ZCD27 + ZCDEP16 + ZCE01 + ZCY49 	ZCD27 + ZCDEP16 + ZCE06
	3-pole NC + NC + NO snap action (XE3S P2141)	ZCD39 + ZCDEP16 + ZCEH0 	ZCD39 + ZCDEP16 + ZCEH2 	ZCD39 + ZCDEP16 + ZCE01 + ZCY18 	ZCD39 + ZCDEP16 + ZCE01 + ZCY45 	ZCD39 + ZCDEP16 + ZCE01 + ZCY39 	ZCD39 + ZCDEP16 + ZCE01 + ZCY49 	ZCD39 + ZCDEP16 + ZCE06
	3-pole NC + NC + NO break before make, slow break (XE3N P2141)	ZCD37 + ZCDEP16 + ZCEH0 	ZCD37 + ZCDEP16 + ZCEH2 	ZCD37 + ZCDEP16 + ZCE01 + ZCY18 	ZCD37 + ZCDEP16 + ZCE01 + ZCY45 	ZCD37 + ZCDEP16 + ZCE01 + ZCY39 	ZCD37 + ZCDEP16 + ZCE01 + ZCY49 	ZCD37 + ZCDEP16 + ZCE06
Weight (kg)	0.220	0.220	0.225	0.235	0.235	0.245	0.175	

References of complete switches with 1 entry for n° 11 cable gland

For an entry tapped for a n° 11 cable gland, replace P16 in the reference by G11. Example: XCKD21H0P16 becomes XCKD21H0G11 or ZCDEP16 becomes ZCDEG11.

Contact operation closed (A) = cam displacement NC contact with positive opening operation
 open (P) = positive opening point

Characteristics

Switch actuation	On end	By 30° cam			By any moving part
Type of actuation					
Maximum actuation speed	0.5 m/s	1.5 m/s			1 m/s (any direct.)
Mechanical durability	10 million operating cycles				
Minimum force or torque	For tripping: 15 N For positive opening: 45 N	10 N 36 N	0.1 N.m 0.25 N.m	0.13 N.m -	
Cable entry	1 entry tapped M16 x 1.5 mm for ISO cable gland, clamping capacity 4 to 8 mm				

(1) Form conforming to EN 50047, see page 24.

(2) Value taken with actuation by moving part at 100 mm from the fixing.

(3) Switches with gold contacts or eyelet type connections: please consult our Customer Care Centre.

Limit switches

XC Standard range

Compact design, metal, XCKD

Complete switches with 1 cable entry

ZCD2● + ZCDEP16/ZCD3● + ZCDEP16

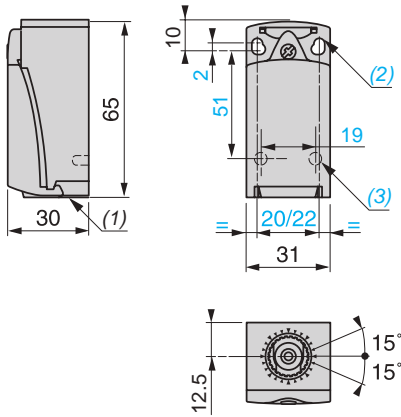

ZCE10

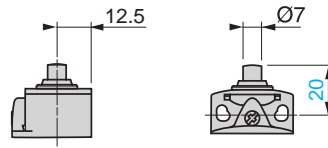

ZCE11

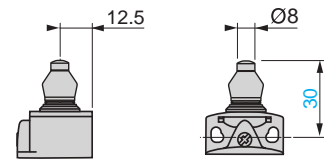

ZCE02

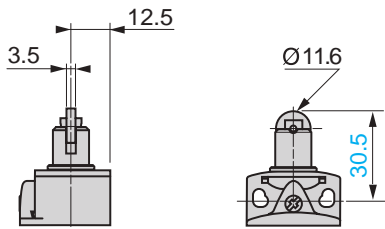

ZCE21

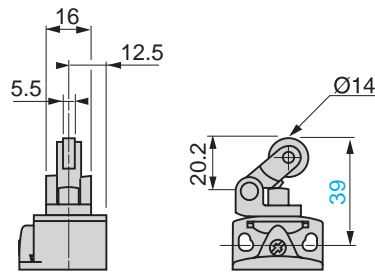

ZCE27

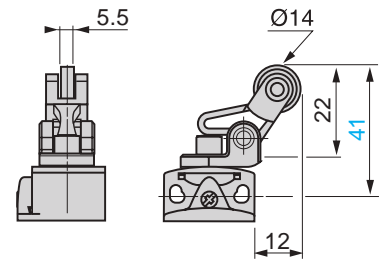

ZCE28

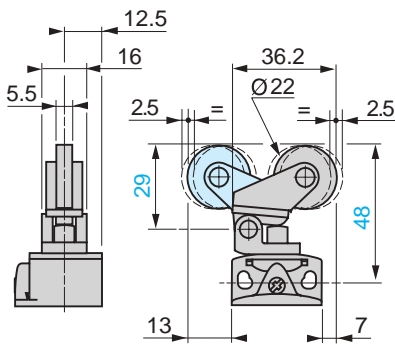

ZCEH0

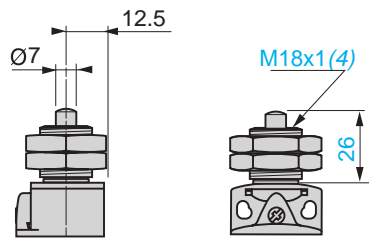

ZCEH2

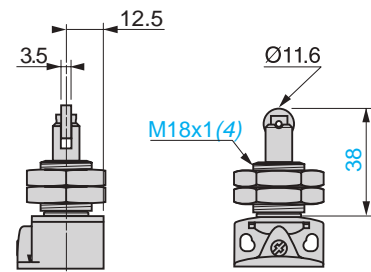

(1) Tapped entry for ISO M16 x 1.5 or Pg 11 cable gland.

(2) 2 elongated holes $\text{Ø} 4.3 \times 6.3$ mm on 22 mm centres, 2 holes $\text{Ø} 4.3$ on 20 mm centres.

(3) 2 x $\text{Ø} 3$ holes for support studs, depth 4 mm.

(4) Fixing nut thickness 3.5 mm.

Limit switches

XC Standard range

Compact design, metal, XCKD

Complete switches with 1 cable entry

ZCE01 + ZCY18

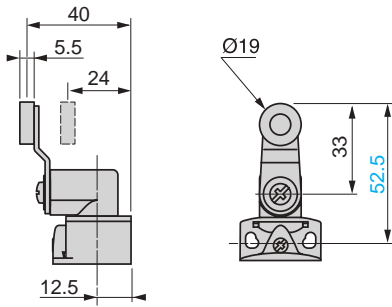

ZCE01 + ZCY45

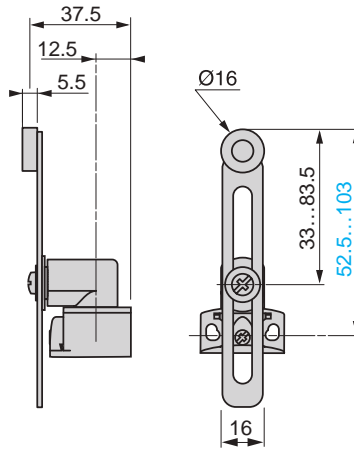

ZCE01 + ZCY39

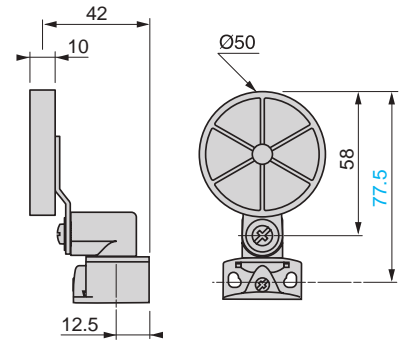

ZCE01 + ZCY49

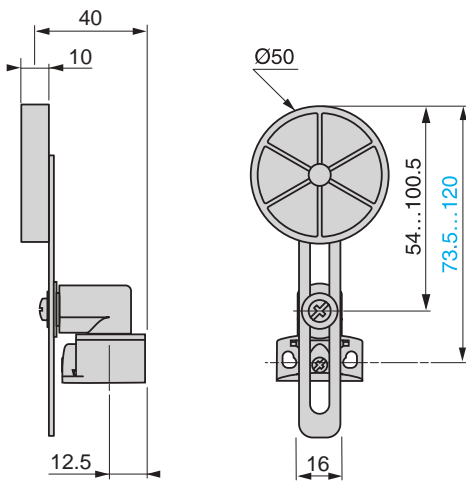



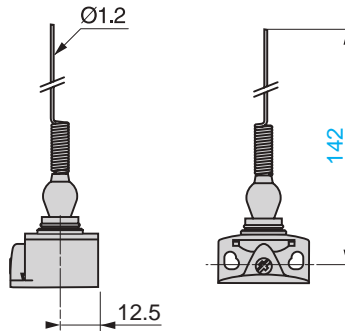











ZCE06

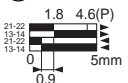

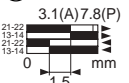
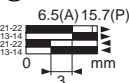
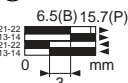

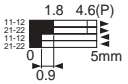
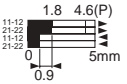
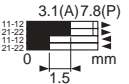
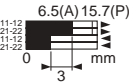
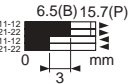
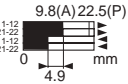
Limit switches

XC Standard range
Compact design, metal, XCKD
M12 connector

Type of head	Plunger (fixing by the body)					
	Form B (1)		Form C (1)	Form E (1)		
						
Type of operator	Metal end plunger		Metal end plunger with elastomer boot (2)	Steel roller plunger	Thermoplastic roller lever plunger, horizontal actuation in 1 direction	Thermoplastic roller lever plunger, vertical actuation in 1 direction

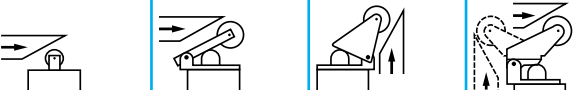
References							
2-pole NC + NO snap action (XE2S P2151)		XCKD2110M12 	XCKD2111M12 	XCKD2102M12 	XCKD2121M12 	XCKD2127M12 	XCKD2128M12 
2-pole NC + NC snap action (XE2S P2141)		ZCD29M12 + ZCE10 	ZCD29M12 + ZCE11 	ZCD29M12 + ZCE02 	ZCD29M12 + ZCE21 	ZCD29M12 + ZCE27 	ZCD29M12 + ZCE28 
Weight (kg)	0.190	0.190	0.195	0.205	0.200	0.205	
Contact operation	 closed  open			(A) (B) = cam displacement (P) = positive opening point	 NC contact with positive opening operation		
(1) Form conforming to EN 50047, see page 24.							
(2) Nitrile for indoor use.							

Characteristics									
Switch actuation	On end / By 30° cam								
Type of actuation	 / 								
Maximum actuation speed	0.5 m/s / 1 m/s								
Mechanical durability (in millions of operating cycles)	15 / 10 / 15								
Minimum force or torque	<table border="1"> <tr> <td>For tripping</td> <td>15 N</td> <td>12 N</td> <td>6 N</td> </tr> <tr> <td>For positive opening</td> <td>45 N</td> <td>36 N</td> <td>18 N</td> </tr> </table>	For tripping	15 N	12 N	6 N	For positive opening	45 N	36 N	18 N
For tripping	15 N	12 N	6 N						
For positive opening	45 N	36 N	18 N						
Connection	M12 connector, Ui = 60 V, Ie = 4 A maximum, lth = 4 A								

Connections									
M12 connector									
	<table border="1"> <tr> <td>XE2S P2151</td> <td>XE2S P2141</td> </tr> <tr> <td>1-2: NC</td> <td>1-2: NC</td> </tr> <tr> <td>3-4: NO</td> <td>3-4: NO</td> </tr> <tr> <td>5: \perp</td> <td>5: \perp</td> </tr> </table>	XE2S P2151	XE2S P2141	1-2: NC	1-2: NC	3-4: NO	3-4: NO	5: \perp	5: \perp
XE2S P2151	XE2S P2141								
1-2: NC	1-2: NC								
3-4: NO	3-4: NO								
5: \perp	5: \perp								

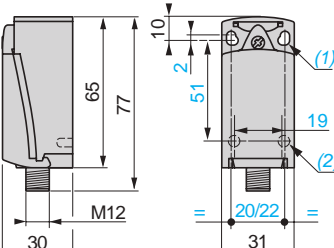
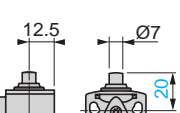
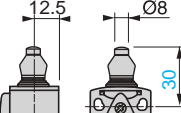
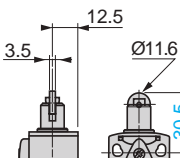
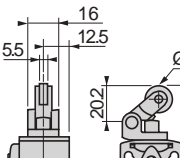
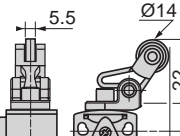
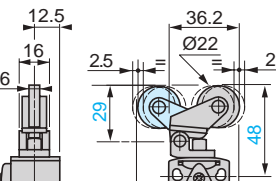
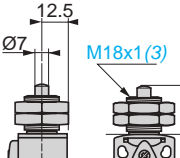
Dimensions	
ZCD2●M12	ZCE10 ZCE11 ZCE02 ZCE21
	   
	ZCE27 ZCE28 ZCEH0
  	
<p>(1) 2 elongated holes \varnothing 4.3 x 6.3 mm on 22 mm centres, 2 holes \varnothing 4.3 on 20 mm centres. (2) 2 x \varnothing 3 holes for support studs, depth 4 mm. (3) Fixing nut thickness 3.5 mm.</p>	

Limit switches

XC Standard range
Compact design, metal, XCKD
M12 connector

Type of head	Plunger (fixing by the head)		Rotary (fixing by the body)				Multi-directional
			Form A (1)				
Type of operator	M18 with metal end plunger	M18 with steel roller plunger	Thermoplastic roller lever	Variable length thermoplastic roller lever	Thermoplastic roller lever, Ø 50 mm	Variable length thermoplastic roller lever, Ø 50 mm	"Cat's whisker" (2)

References	XCKD21H2M12		XCKD2118M12	XCKD2145M12	XCKD2149M12	XCKD2106M12	
2-pole NC + NO snap action (XE2S P2151)	-	3.1(A) 7.8(P)	25° 70°(P)	25° 70°(P)	25° 70°(P)	20°	
2-pole NC + NC snap action (XE2S P2141)	ZCD29M12 + ZCEH0	ZCD29M12 + ZCEH2	ZCD29M12 + ZCE01 + ZCY18	ZCD29M12 + ZCE01 + ZCY45	ZCD29M12 + ZCE01 + ZCY39	ZCD29M12 + ZCE01 + ZCY49	ZCD29M12 + ZCE06
Weight (kg)	0.235	0.235	0.220	0.220	0.220	0.220	0.185
Contact operation	closed open		(A) = cam displacement (P) = positive opening point		NC contact with positive opening operation		

(1) Form conforming to EN 50047, see page 24.
(2) Value taken with actuation by moving part at 100 mm from the fixing.

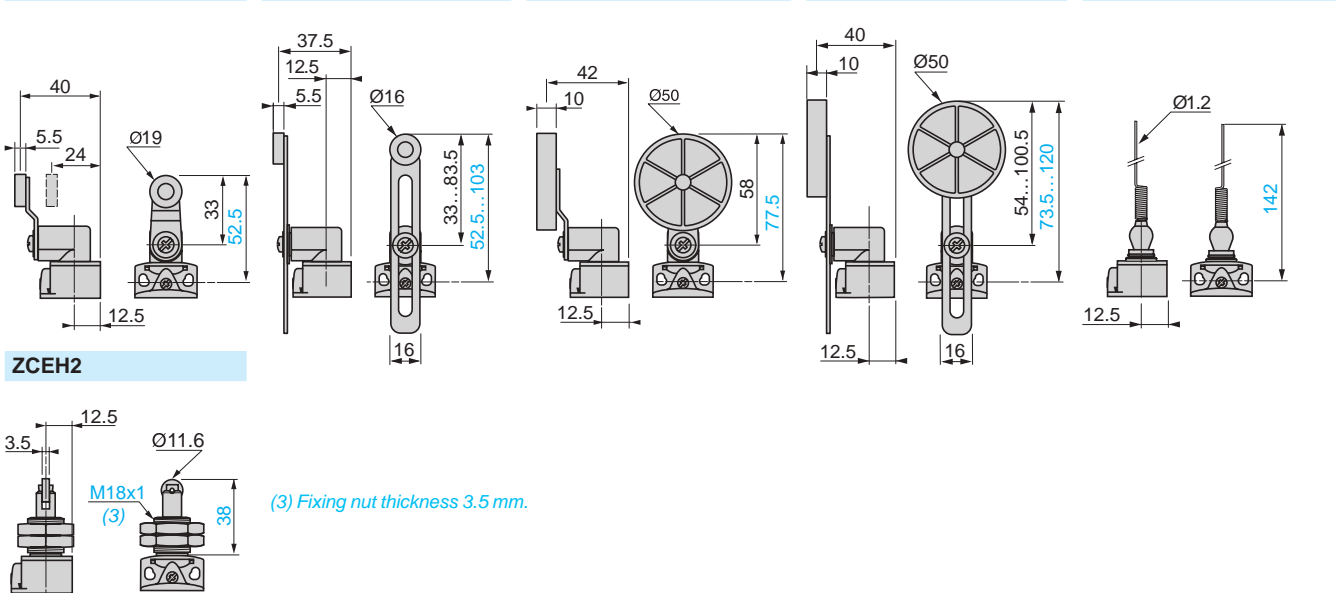

Characteristics	On end	By 30° cam	By any moving part
Switch actuation	On end	By 30° cam	By any moving part
Type of actuation			
Maximum actuation speed	0.5 m/s	1.5 m/s	1 m/s (any direct.)
Mechanical durability (in millions of operating cycles)	10	5	5
Minimum force or torque	For tripping: 15 N For positive opening: 45 N	10 N 36 N	0.1 N.m 0.25 N.m
Connection	M12 connector, U _i = 60 V, I _e = 4 A maximum, I _{th} = 4 A		

Dimensions



Limit switches

XC Standard range
Compact design, plastic, XCKT
Complete switches with 2 cable entries

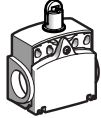
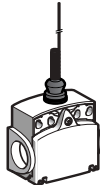
Type of head	Plunger (fixing by the body)			Multi-directional
	Form B (1)	Form C (1)	Form E (1)	
				
Type of operator	Metal end plunger	Metal end plunger with elastomer boot (2)	Steel roller plunger	Thermoplastic roller lever plunger, horizontal actuation in 1 direction





References of complete switches with 2 ISO M16 x 1.5 cable entries (4)

	XCKT2110P16	XCKT2111P16	XCKT2102P16	XCKT2121P16	XCKT2106P16
 2-pole NC + NO snap action (XE2SP3151)					
 2-pole NC + NO break before make, slow break (XE2NP3151)					
 2-pole NC + NO make before break, slow break (XE2NP3161)					
 2-pole NC + NC simultaneous, slow break (XE2NP2141)					
 2-pole NO + NO simultaneous, slow break (XE2NP3131)					
Weight (kg)	0.100	0.100	0.105	0.115	0.095

References of complete switches with 2 entries for n° 11 cable gland

For entries tapped for n° 11 cable gland, replace P16 in the reference by G11. Example: XCKT2110P16 becomes XCKT2110G11.

Contact operation  closed (A) = cam displacement  NC contact with positive opening operation
 open (P) = positive opening point

Characteristics				
Switch actuation	On end	By 30° cam		By any moving part
Type of actuation				
Maximum actuation speed	0.5 m/s		1 m/s	1 m/s (any direction)
Mechanical durability (in millions of operating cycles)	15	10	15	5
Minimum force or torque	For tripping: 15 N For positive opening: 45 N	12 N 36 N	6 N 18 N	0.3 N.m
Cable entry (3)	2 entries tapped M16 x 1.5 for ISO cable gland Clamping capacity 4 to 8 mm (1 entry fitted with blanking plug)			

(1) Form conforming to EN 50047, see page 24. (2) Nitrile for indoor use.

(3) Value taken with actuation by moving part at 100 mm from the fixing. (4) Switches with gold contacts or eyelet type connections: please consult our Customer Care Centre.

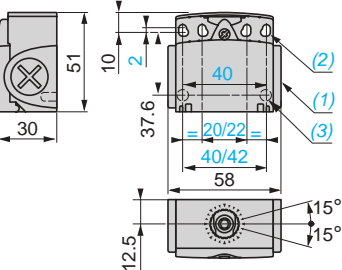
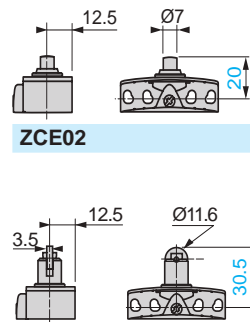
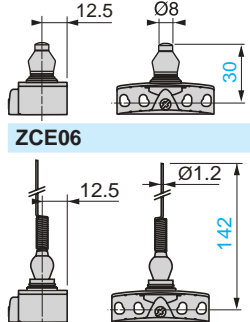
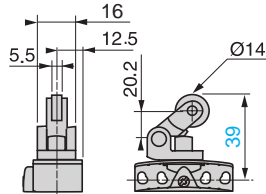

Dimensions

ZCT2•P16	ZCE10	ZCE11	ZCE21
			







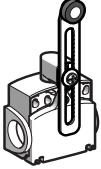
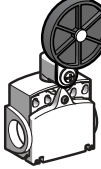

- (1) Tapped entry for ISO M16 x 1.5 or Pg 11 cable gland.
 (2) 4 elongated holes \varnothing 4.3 x 6.3 mm on 22/42 mm ctrs, 4 holes \varnothing 4.3 on 20/40 mm ctrs.
 (3) 2 x \varnothing 3 holes for support studs, depth 4 mm.

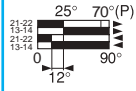
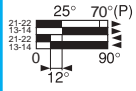
Limit switches

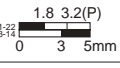
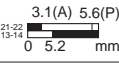
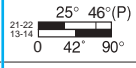
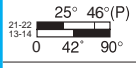
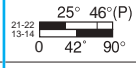
XC Standard range
Compact design, plastic, XCKT
Complete switches with 2 cable entries

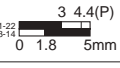
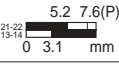
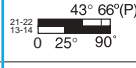
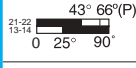
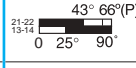

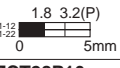
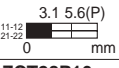
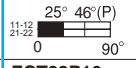
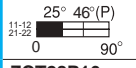
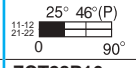
Type of head	Plunger (fixing by the head)		Rotary (fixing by the body) Form A (1)		
					
Type of operator	M18 with metal end plunger	M18 with steel roller plunger	Thermoplastic roller lever	Variable length thermoplastic roller lever	Thermoplastic roller lever, Ø 50 mm

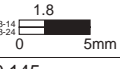
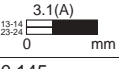
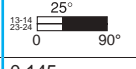
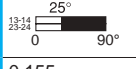
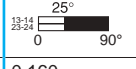
References of complete switches with 2 ISO M16 x 1.5 cable entries (2)



	2-pole NC + NO snap action (XE2SP3151)	-	-	XCKT2118P16 	XCKT2145P16 	-
	2-pole NC + NO break before make, slow break (XE2NP3151)	ZCT25P16 + ZCEH0 	ZCT25P16 + ZCEH2 	ZCT25P16 + ZCE01 + ZCY18 	ZCT25P16 + ZCE01 + ZCY45 	ZCT25P16 + ZCE01 + ZCY39 
	2-pole NO + NC make before break, slow break (XE2NP3161)	ZCT26P16 + ZCEH0 	ZCT26P16 + ZCEH2 	ZCT26P16 + ZCE01 + ZCY18 	ZCT26P16 + ZCE01 + ZCY45 	ZCT26P16 + ZCE01 + ZCY39 
	2-pole NC + NC simultaneous, slow break (XE2NP2141)	ZCT27P16 + ZCEH0 	ZCT27P16 + ZCEH2 	ZCT27P16 + ZCE01 + ZCY18 	ZCT27P16 + ZCE01 + ZCY45 	ZCT27P16 + ZCE01 + ZCY39 
	2-pole NO + NO simultaneous, slow break (XE2NP3131)	ZCT28P16 + ZCEH0 	ZCT28P16 + ZCEH2 	ZCT28P16 + ZCE01 + ZCY18 	ZCT28P16 + ZCE01 + ZCY45 	ZCT28P16 + ZCE01 + ZCY39 
Weight (kg)	0.145	0.145	0.145	0.155	0.160	

References of complete switches with 2 entries for n° 11 cable gland

For entries tapped for n° 11 cable gland, replace P16 in the reference by G11. Example: XCKT21H0P16 becomes XCKT21H0G11.

Contact operation  closed (A) = cam displacement  NC contact with positive opening operation
 open (P) = positive opening point

Characteristics

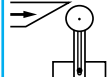
Switch actuation	On end	By 30° cam		
Type of actuation				
Maximum actuation speed	0.5 m/s		1.5 m/s	
Mechanical durability	10 million operating cycles			
Minimum force or torque	For tripping	15 N	10 N	0.1 N.m
	For positive opening	45 N	36 N	0.25 N.m
Cable entry (3)	2 entries tapped M16 x 1.5 for ISO cable gland Clamping capacity 4 to 8 mm (1 entry fitted with blanking plug)			

(1) Form conforming to EN 50047, see page 24.

(2) Switches with gold contacts or eyelet type connections: please consult our Customer Care Centre.

Dimensions

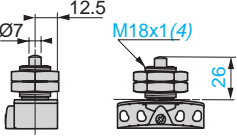
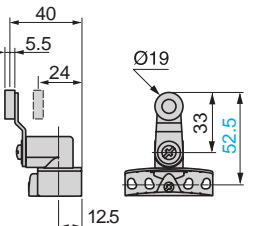
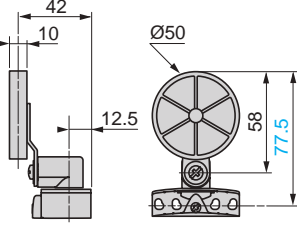
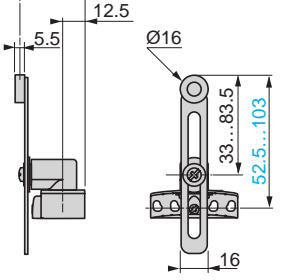
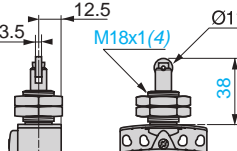
ZCEH0	ZCE01 + ZCY18	ZCE01 + ZCY39	ZCE01 + ZCY45
			
			

(4) Fixing nut thickness 3.5 mm.

Limit switches

XC Standard range

Compact design, XCKD, XCKP and XCKT

Variable composition

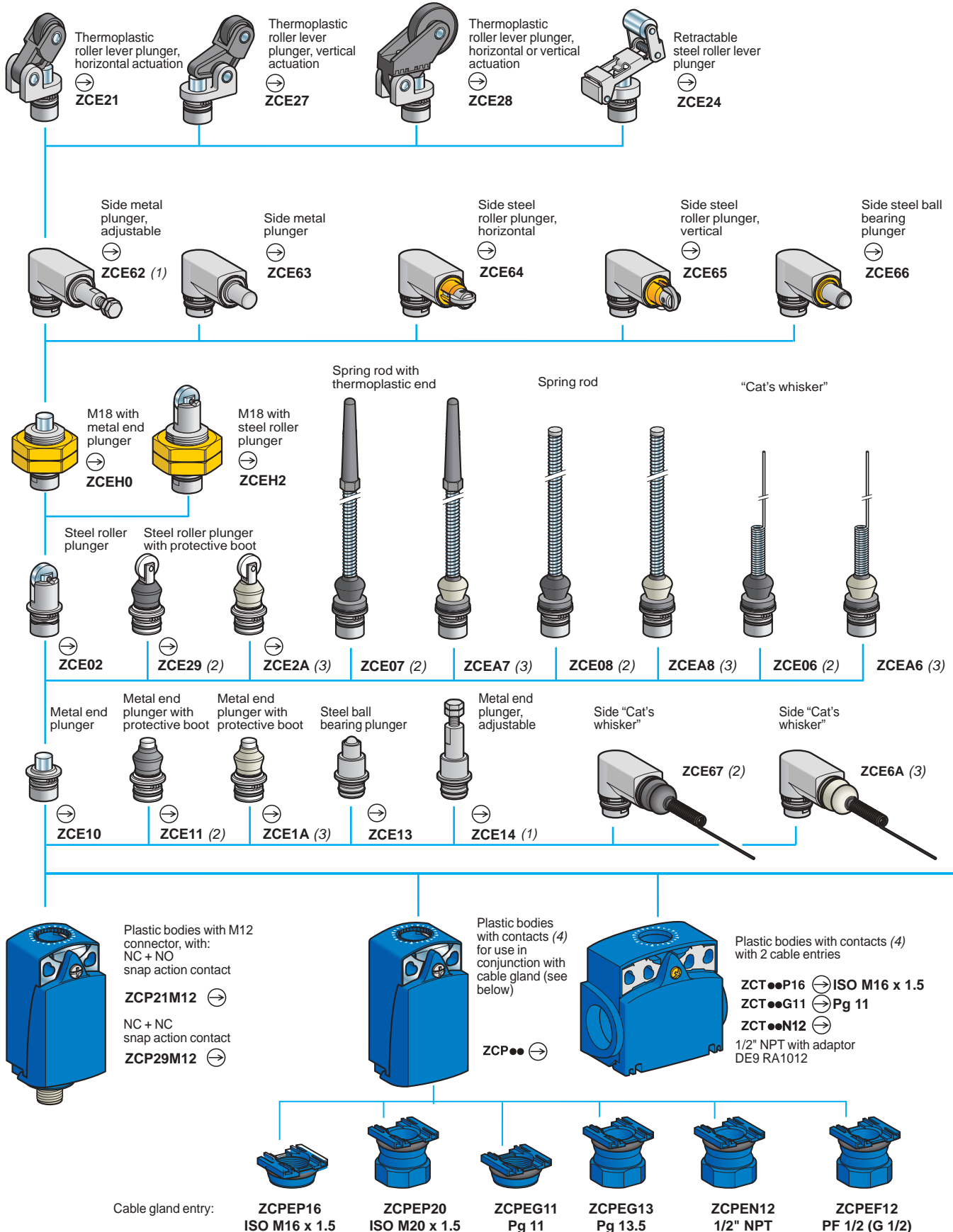

(1) A minimum 5 mm of threaded length must be maintained inside the head. Plunger length can be adjusted from 30.5 to 35.5 mm.

(2) Nitrile boot for indoor use.

(3) Silicone boot for outdoor use.

(4) For further information, see page 94.

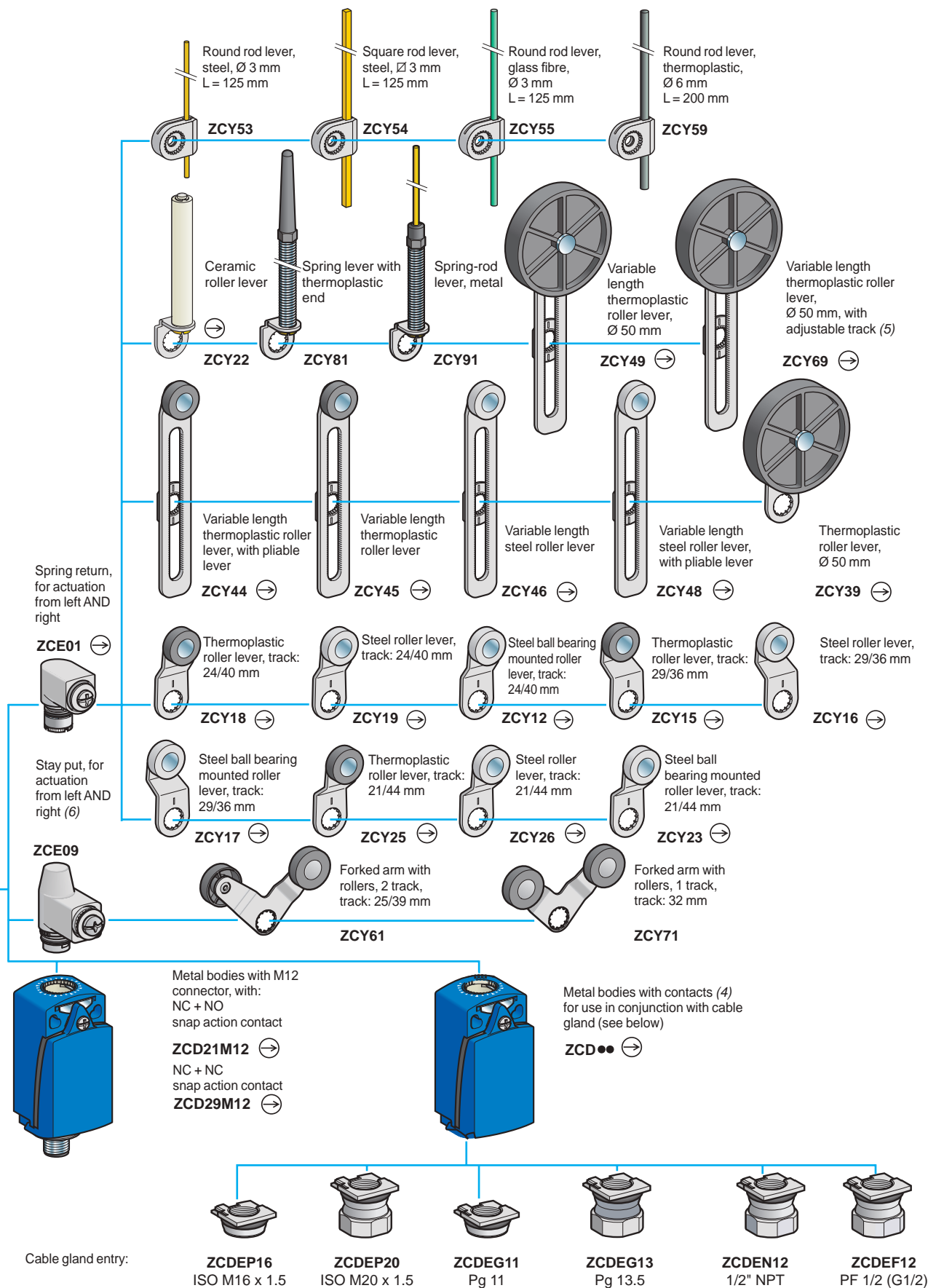

(5) Variable length and adjustable track by lever deformation.

(6) Suitable with bodies: ZCD21, ZCP21, ZCT21, ZCD29, ZCP29, ZCD31, ZCP31, ZCD39, ZCP39, ZCD2●M12, ZCP2●M12

Limit switches

XC Standard range
Compact design, metal, XCKD
or plastic, XCKP

Adaptable sub-assemblies: bodies with contacts

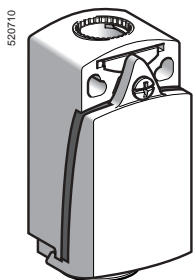

ZCD●●

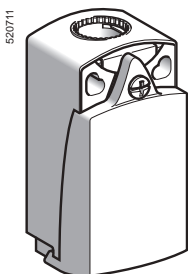

ZCP●●

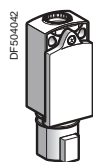

ZCP21D44

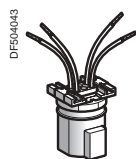

ZCPED44

Bodies with contacts, XCKD and XCKP (1)

Type of contact	Positive operation (2)	Scheme	Body material	Reference	Weight kg
2-pole					
NC + NO snap action (XE2SP2151)	⊖		Metal	ZCD21	0.140
			Plastic	ZCP21	0.070
NC + NC snap action (XE2SP2141)	⊖		Metal	ZCD29	0.140
			Plastic	ZCP29	0.070
NC + NO break before make, slow break (XE2NP2151)	⊖		Metal	ZCD25	0.140
			Plastic	ZCP25	0.070
NO + NC make before break, slow break (XE2NP2161)	⊖		Metal	ZCD26	0.140
			Plastic	ZCP26	0.070
NC + NC simultaneous, slow break (XE2NP2141)	⊖		Metal	ZCD27	0.140
			Plastic	ZCP27	0.070
NO + NO simultaneous, slow break (XE2NP2131)	-		Metal	ZCD28	0.140
			Plastic	ZCP28	0.070
3-pole					
NC + NO + NO snap action (XE3SP2151)	⊖		Metal	ZCD31	0.140
			Plastic	ZCP31	0.070
NC + NC + NO snap action (XE3SP2141)	⊖		Metal	ZCD39	0.140
			Plastic	ZCP39	0.070
NC + NC + NO break before make, slow break (XE3NP2141)	⊖		Metal	ZCD37	0.140
			Plastic	ZCP37	0.070
NC + NO + NO break before make, slow break (XE3NP2151)	⊖		Metal	ZCD35	0.140

Components for connection using DEUTSCH connector

Bodies with contacts for DEUTSCH connector

Type of contact	Positive operation (2)	Scheme	Cable entry	Reference	Weight kg
2-pole					
NC + NO snap action (XE2SP2151)	⊖		Connector	ZCP21D44	0.065
DEUTSCH male connector DT04-4P				ZCPED44	0.015

(1) Bodies with gold contacts or eyelet type connections: please consult your Regional Sales Office.

(2) ⊖: bodies with contacts assuring positive opening operation.

Limit switches

XC Standard range

Compact design, plastic, XCKT

Adaptable sub-assemblies: bodies with contacts

561390

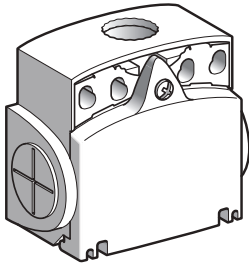

ZCT...●●

Bodies with contacts, XCKT plastic, 2 cable entries

Type of contact	Positive operation (1)	Scheme	Cable entries	Reference	Weight kg
2-pole					
NC + NO snap action (XE2SP3151)	⊖		ISO M16 x 1.5	ZCT21P16	0.085
			Pg 11	ZCT21G11	0.085
NC + NO break before make, slow break (XE2NP3151)	⊖		ISO M16 x 1.5	ZCT25P16	0.085
			Pg 11	ZCT25G11	0.085
NC + NC simultaneous, slow break (XE2NP3141)	⊖		ISO M16 x 1.5	ZCT27P16	0.085
			Pg 11	ZCT27G11	0.085
NO + NO simultaneous, slow break (XE2NP3131)	-		ISO M16 x 1.5	ZCT28P16	0.085
			Pg 11	ZCT28G11	0.085
NO + NC make before break, slow break (XE2NP3161)	⊖		ISO M16 x 1.5	ZCT26P16	0.085
			Pg 11	ZCT26G11	0.085

561387

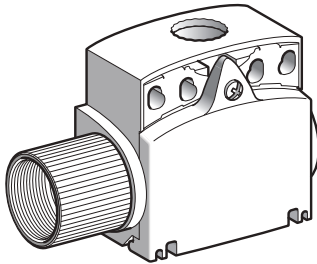

ZCT...●●N12

Bodies with contacts, XCKT plastic, 2 cable entries with 1/2" NPT adaptor

Type of contact	Positive operation (1)	Scheme	Reference	Weight kg
2-pole				
NC + NO snap action (XE2SP3151)	⊖		ZCT21N12	0.130
NC + NO break before make, slow break (XE2NP3151)	⊖		ZCT25N12	0.130
NC + NC simultaneous, slow break (XE2NP3141)	⊖		ZCT27N12	0.130
NO + NO simultaneous, slow break (XE2NP3131)	-		ZCT28N12	0.130

(1) ⊖: bodies with contact assuring positive opening operation.

Limit switches

XC Standard range

Compact design, metal, XCKD or plastic, XCKP and XCKT

Adaptable sub-assemblies: bodies with contacts

56127

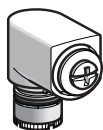

ZCE05

561392



DE9RA1012

561388

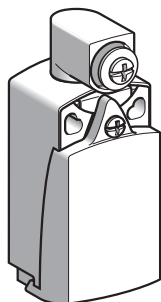

XCK2001

Accessories

Description	Suitable levers for use with head	Unit reference	Weight kg
Rotary head, without lever, spring return, for actuation from left AND right or left OR right (1)	ZCY12, ZCY15, ZCY16, ZCY17, ZCY18, ZCY19, ZCY22, ZCY23, ZCY25, ZCY26, ZCY39, ZCY53, ZCY54, ZCY55, ZCY81	ZCE05	0.045
Spacer for angular positioning of heads with adjustable levers, for values other than - 90°, 0° and 90°	-	XCMZ07	0.002
Adaptor for 1/2" NPT conduit (male Pg 11 / female 1/2" NPT)	Sold in lots of 10	DE9RA1012	0.050

Bodies with contacts, XCKP plastic, with rotary head (without operating lever)

Type of contact	Scheme	Positive operation (2)	Cable entry	Reference	Weight kg
2-pole					
NC + NO snap action (XE2SP2151)			ISO M16 x 1.5	XCKP2101P16	0.115
			Pg 11	XCKP2101G11	0.115

Bodies with contacts, XCKD metal, with rotary head (without operating lever)

Type of contact	Scheme	Positive operation (2)	Cable entry	Reference	Weight kg
2-pole					
NC + NO snap action (XE2SP2151)			ISO M16 x 1.5	XCKD2101P16	0.185
			Pg 11	XCKD2101G11	0.185

(1) For programming see page 18.

(2) : bodies with contact assuring positive opening operation.

Limit switches

XC Standard range

Compact design, metal, XCKD or plastic, XCKP and XCKT

Adaptable sub-assemblies: contact blocks

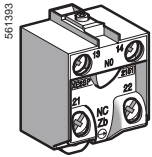

XE2●●21●●

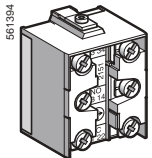

XE3●●21●●

Contact blocks with screw clamp terminals for XCKD and XCKP

Type of contact	Positive operation (1)	Scheme	Reference for standard contacts	Weight kg
2-pole				
NC + NO snap action	⊕		XE2SP2151	0.020
NC + NC simultaneous, snap action	⊕		XE2SP2141	0.020
NC + NO break before make, slow break	⊕		XE2NP2151	0.020
NO + NC make before break, slow break	⊕		XE2NP2161	0.020
NC + NC simultaneous, slow break	⊕		XE2NP2141	0.020
NO + NO simultaneous, slow break	-		XE2NP2131	0.020
3-pole				
NC + NO + NO snap action	⊕		XE3SP2151	0.035
NC + NC + NO snap action	⊕		XE3SP2141	0.035
NC + NC + NO break before make, slow break	⊕		XE3NP2141	0.035
NC + NO + NO break before make, slow break	⊕		XE3NP2151	0.035

Contact blocks with screw clamp terminals for XCKT

Type of contact	Positive operation (1)	Scheme	Reference for standard contacts	Weight kg
2-pole				
NC + NO snap action	⊕		XE2SP3151	0.015
NC + NO break before make, slow break	⊕		XE2NP3151	0.015
NO + NC make before break, slow break	⊕		XE2NP3161	0.015
NC + NC simultaneous, slow break	⊕		XE2NP3141	0.015
NO + NO simultaneous, slow break	-		XE2NP3131	0.015

(1) ⊕: contact blocks assuring positive opening operation.

Limit switches

XC Standard range

Compact design, plastic, with reset, XCPR and XCTR

■ **XCPR**
with 1 cable entry

□ With head for linear movement (plunger). Fixing by the body
XCPR

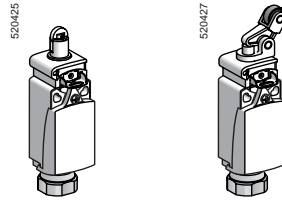

Page 100

□ With head for rotary movement (lever) or multi-directional. Fixing by the body
XCPR

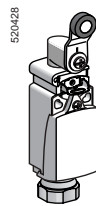

Page 100

■ **XCTR**
with 2 cable entries
Tripping/resetting points and fixing centres
conform to CENELEC 50047

□ With head for linear movement (plunger). Fixing by the body
XCTR

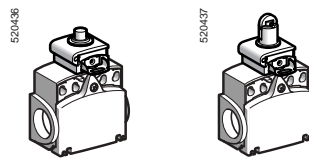

Page 102

□ With head for rotary movement (lever) or multi-directional. Fixing by the body
XCTR

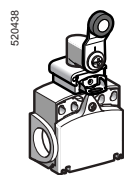

Page 102









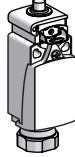

Environment characteristics		
Conformity to standards	Products	CE, EN/IEC 60947-5-1, UL 508, CSA C22-2 n° 14, EAC
	Machine assemblies	EN/IEC 60204-1
Product certifications		UL, CSA
Protective treatment	Standard version	"TC"
Ambient air temperature	For operation	- 25...+ 70 °C (- 40...+ 70 °C with ZCE106, ZCE026 and ZCE016 heads)
	For storage	- 40...+ 70 °C
Vibration resistance	Conforming to IEC 60068-2-6	25 gn (10...500 Hz)
Shock resistance	Conforming to IEC 60068-2-27	50 gn (11 ms)
Electric shock protection		Class II conforming to IEC 61140 and NF C 20-030
Degree of protection		IP 66 and IP 67 conforming to IEC 60529 IK 04 conforming to IEC 62262
Repeat accuracy		0.1 mm on the tripping points, with 1 million operating cycles for head with end plunger
Cable entry	Depending on model	Either: tapped entry for n° 13 cable gland, tapped ISO M20 x 1.5 or tapped 1/2" NPT
Materials		Plastic bodies, Zamak heads
Contact block characteristics		
Rated operational characteristics		~ AC-15; A300 (Ue = 240 V, Ie = 3 A); Ithe = 10 A = DC-13; Q300 (Ue = 250 V, Ie = 0.27 A), conforming to EN/IEC 60947-5-1 Appendix A
Rated insulation voltage		Ui = 500 V degree of pollution 3 conforming to IEN/IEC 60947-1 Ui = 300 V conforming to UL 508, CSA C22-2 n° 14
Rated impulse withstand voltage		U imp = 6 kV conforming to EN/IEC 60947-1, IEC 60664
Positive operation (depending on model)		NC contacts with positive opening operation conforming to EN/IEC 60947-5-1 Appendix K
Resistance across terminals		≤ 25 mΩ conforming to IEC 60255-7 category 3
Short-circuit protection		10 A cartridge fuse type gG (gl)
Connection (screw clamp terminals)	XE2SP2151	Clamping capacity, min: 1 x 0.34 mm ² , max: 2 x 1.5 mm ²
	XE2NP2151	Clamping capacity, min: 1 x 0.5 mm ² , max: 2 x 2.5 mm ²
Minimum actuation speed (for head with end plunger)		XE2SP2151 : 0.01 m/minute
		XE2NP2151 : 6 m/minute

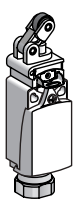
Limit switches

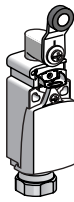
XC Standard range

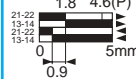
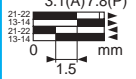
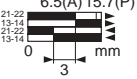
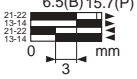
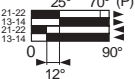
Compact design, plastic, with reset, XCPR

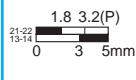
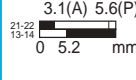
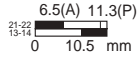
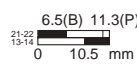
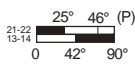
Complete switches with 1 cable entry

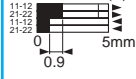
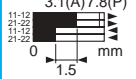
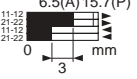
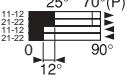
Type of head	Plunger (fixing by the body)			Rotary (fixing by the body)		
						
Type of operator	Metal end plunger	Steel roller plunger	Thermoplastic roller lever plunger, horizontal actuation in 1 direction	Thermoplastic roller lever plunger, vertical actuation in 1 direction	Thermoplastic roller lever	Steel roller lever
References of complete switches with 1 ISO M20 x 1.5 cable entry						
	2-pole NC + NO snap action (XE2SP2151)	XCPR2110P20 	XCPR2102P20 	XCPR2121P20 	XCPR2127P20 	XCPR2118P20 
	2-pole NC + NO break before make, slow break (XE2NP2151)	XCPR2510P20 	XCPR2502P20 	XCPR2521P20 	XCPR2527P20 	XCPR2518P20 
	2-pole NC + NC snap action (XE2SP2141)	XCPR2910P20 	XCPR2902P20 	XCPR2921P20 	–	XCPR2918P20 
Weight (kg)	0.115	0.115	0.125	0.125	0.155	0.155

References of complete switches with 1 Pg 13.5 cable entry

For complete switches with 1 Pg 13.5 cable entry replace P20 by G13.

Example: XCPR2110P20 becomes **XCPR2110G13**.





References of complete switches with 1 entry for 1/2" NPT conduit

For complete switches with 1 entry for 1/2" NPT conduit replace P20 by N12.

Example: XCPR2110P20 becomes **XCPR2110N12**.

Contact operation	 closed  open	(A) (B) = cam displacement (P) = positive opening point	 NC contact with positive opening operation
--------------------------	--	--	--

Characteristics

Switch actuation	On end	By 30° cam		
Type of actuation				
Maximum actuation speed	0.5 m/s	1 m/s		
Minimum force or torque	For tripping	15 N	12 N	6 N
	For positive opening	45 N	36 N	18 N
Cable entry	1 entry tapped M20 x 1.5 mm for ISO cable gland, clamping capacity 7 to 13 mm 1 entry tapped Pg 13.5 for cable gland, clamping capacity 9 to 12 mm 1 entry tapped for 1/2" NPT (USAS B2-1) conduit			

Other versions

Complete switches with cable entries other than those listed above. please consult our Customer Care Centre.

Limit switches

XC Standard range

Compact design, plastic, with reset, XCPR

Complete switches with 1 cable entry

Dimensions

XCPR2●10●●●

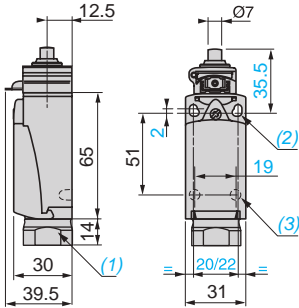

XCPR2●02●●●

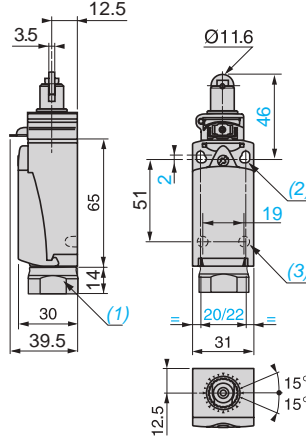

XCPR2●21●●●

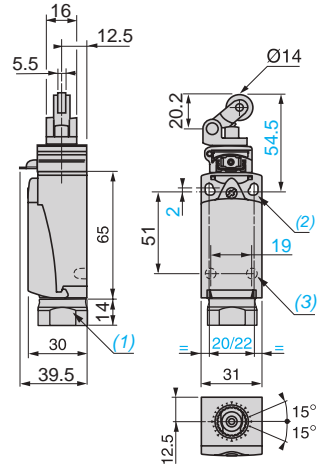

(1) Tapped entry for ISO M20 x 1.5 or Pg 13.5 cable gland or tapped 1/2" NPT.

(2) 2 elongated holes $\varnothing 4.3 \times 6.3$ mm on 22 mm centres, 2 holes $\varnothing 4.3$ on 20 mm centres.

(3) 2 x $\varnothing 3$ holes for support studs, depth 4 mm.

Dimensions

XCPR2●27●●●

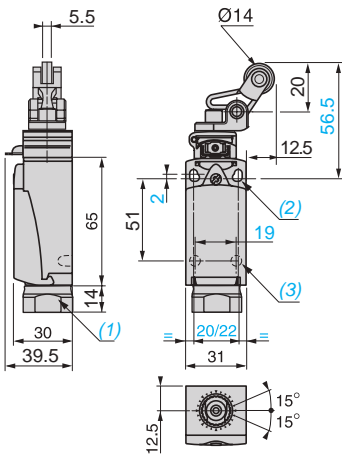

XCPR2●18●●●, XCPR2●19●●●

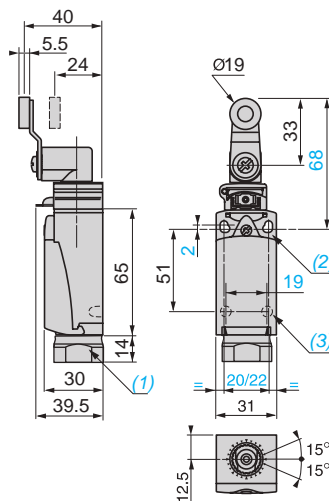

(1) Tapped entry for ISO M20 x 1.5 or Pg 13.5 cable gland or tapped 1/2" NPT.

(2) 2 elongated holes $\varnothing 4.3 \times 6.3$ mm on 22 mm centres, 2 holes $\varnothing 4.3$ on 20 mm centres.

(3) 2 x $\varnothing 3$ holes for support studs, depth 4 mm.

Limit switches

XC Standard range

Compact design, plastic, with reset, XCTR

Complete switches with 2 cable entries

Type of head	Plunger (fixing by the body)		
--------------	------------------------------	--	--

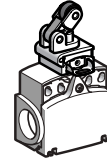
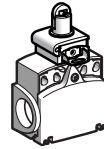
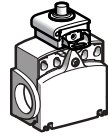

Type of operator	Metal end plunger	Steel roller plunger	Thermoplastic roller lever plunger, horizontal actuation in 1 direction
------------------	-------------------	----------------------	---

References of complete switches with 2 ISO M16 x 1.5 cable entries

<p>2-pole NC + NO snap action (XE2SP3151)</p>	<p>XCTR2110P16 (↻)</p>	<p>XCTR2102P16 (↻)</p>	<p>XCTR2121P16 (↻)</p>
	<p>—</p>	<p>XCTR2502P16 (↻)</p>	<p>XCTR2521P16 (↻)</p>
Weight (kg)	0.120	0.125	0.135

References of complete switches with 2 Pg 11 cable entries

For complete switches with 2 Pg 11 cable entries replace P16 by **G11**.
Example: XCTR2110P16 becomes **XCTR2110G11**.

References of complete switches with 2 entries tapped for 1/2" NPT conduit

For complete switches with 2 entries for 1/2" NPT conduit replace P16 by **N12**.
Example: XCTR2110P16 becomes **XCTR2110N12**.

<p>Contact operation</p> <p> closed open </p>	<p>(A) = cam displacement (P) = positive opening point ↻ = NC contact with positive opening operation</p>
--	---

Characteristics

Switch actuation	On end	By 30° cam	
Type of actuation			
Maximum actuation speed	0.5 m/s	1 m/s	
Minimum force or torque	For tripping	15 N	12 N
	For positive opening	45 N	36 N
Cable entry (1 entry fitted with blanking plug)	2 entries tapped M16 x 1.5 mm for ISO cable gland, clamping capacity 4 to 8 mm 2 entries tapped Pg 11 for cable gland, clamping capacity 7 to 10 mm 2 entries tapped for 1/2" NPT (USAS B2-1) conduit using Pg 11 - 1/2" NPT adaptor DE9RA1012		

Limit switches

XC Standard range

Compact design, plastic, with reset, XCTR

Complete switches with 2 cable entries

Dimensions

XCTR2●10●●●

XCTR2●02●●●

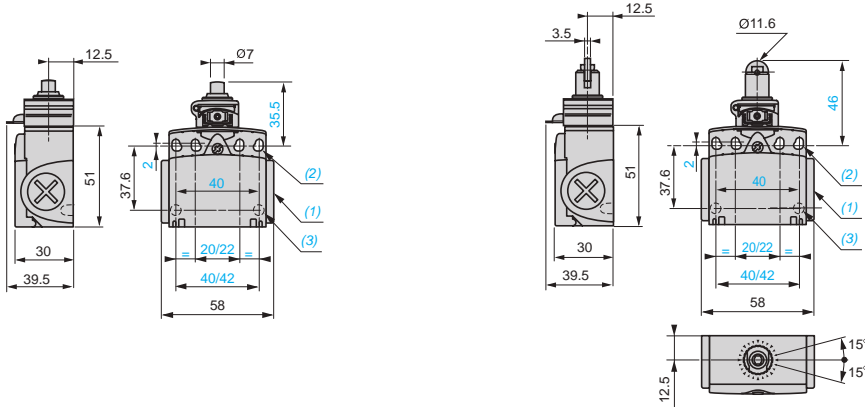

- (1) Tapped entry for ISO M16 x 1.5 or Pg 11 cable gland or tapped 1/2" NPT.
- (2) 4 elongated holes \varnothing 4.3 x 6.3 mm on 22/42 mm centres, 4 holes \varnothing 4.3 on 20/40 mm centres.
- (3) 2 x \varnothing 3 holes for support studs, depth 4 mm.
- (4) Tapped entry for 1/2" NPT conduit.
- (5) Pg 11 threaded sleeve.

Dimensions

XCTR2●21●●●

DE9RA1012

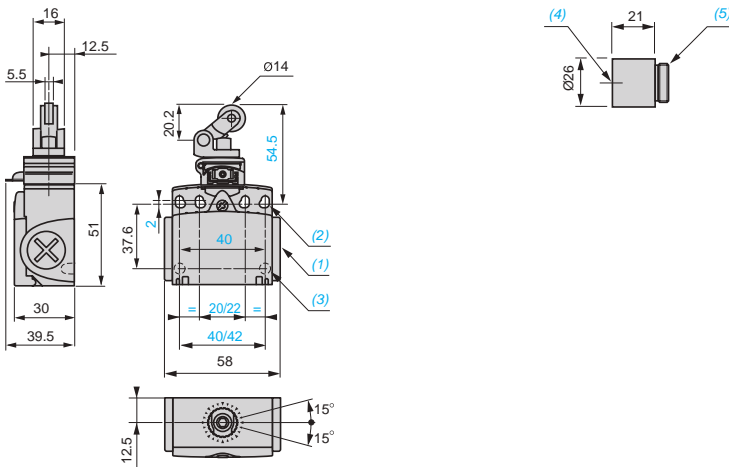

- (1) Tapped entry for ISO M16 x 1.5 or Pg 11 cable gland or 1/2" NPT conduit.
- (2) 4 elongated holes \varnothing 4.3 x 6.3 mm on 22/42 mm centres, 4 holes \varnothing 4.3 on 20/40 mm centres.
- (3) 2 x \varnothing 3 holes for support studs, depth 4 mm.

Limit switches

XC Basic range

Compact design, plastic, XCKN and XCNT

■ XCKN

with 1 cable entry

Conforming to CENELEC EN 50047

□ With head for linear movement (plunger)

530748

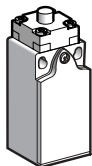

530745

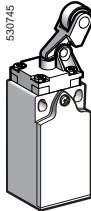

600039

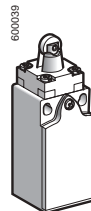

Page 106

□ With head for rotary movement (lever) or multi-directional

530749

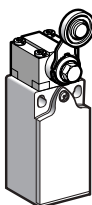

530746



Page 107

■ XCNT

with 2 cable entries

Conforming to CENELEC EN 50047

□ With head for linear movement (plunger)

DF600177

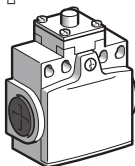

DF600178

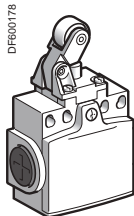

DF600352

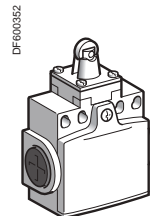

Page 108

□ With head for rotary movement (lever) or multi-directional

DF600180

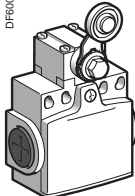

DF600181

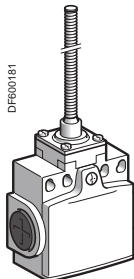



Page 108





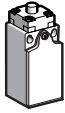
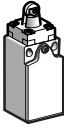
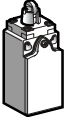





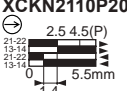
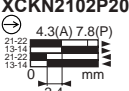
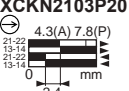

Environment characteristics		
Conformity to standards	Products	IEC 60947-5-1, EN 60947-5-1, UL 508, CSA C22-2 n° 14, EAC
	Machine assemblies	IEC 60204-1, EN 60204-1
Product certifications		UL, CSA, CCC
Protective treatment	Version	Standard: "TC"
Ambient air temperature	For operation	- 25...+ 70°C
	For storage	- 40...+ 70°C
Vibration resistance	Conforming to IEC 60068-2-6	25 gn (10...500 Hz) except XCKN●●08: 10 gn, XCKN●●39 and XCKN●●49: 15 gn
Shock resistance	Conforming to IEC 60068-2-27	50 gn (11 ms) except XCKN2●49●● and XCKN●●39: 15 gn, XCKN2●08●●: 20 gn and XCKN2●45●●: 35 gn
Electric shock protection		Class II conforming to IEC 61140 and NF C 20030
Degree of protection		IP 65 conforming to IEC 60529; IK 04 conforming to IEC 62262
Cable entry		Depending on model: tapped entry for ISO M20 x 1.5 or Pg 11 cable gland, ISO M 16 x 1.5 cable gland or PF 1/2 (G 1/2).
Materials	Bodies	Plastic
	Heads	Plastic
Contact block characteristics		
Rated operational characteristics		~ AC-15; A300 (U _e = 240 V, I _e = 3 A); I _{the} = 10 A ≡ DC-13; R300 (U _e = 250 V, I _e = 0.1 A), conforming to IEC 60947-5-1 Appendix A, EN 60947-5-1
Rated insulation voltage	2-pole contact	U _i = 500 V degree of pollution 3 conforming to IEC 60947-1 U _i = 300 V conforming to UL 508, CSA C22-2 n° 14
Rated impulse withstand voltage	2-pole contact	U _{imp} = 6 kV conforming to IEC 60947-1, IEC 60664
Positive operation		NC contacts with positive opening operation conforming to IEC 60947-5-1 Appendix K, EN 60947-5-1
Short-circuit protection		10 A cartridge fuse type gG (gl)
Connection	Screw clamp terminals	Clamping capacity, min: 1 x 0.34 mm ² , max: 2 x 1.5 mm ²

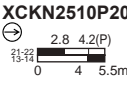
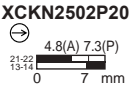
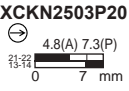
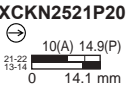
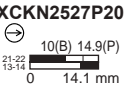

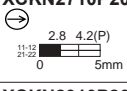
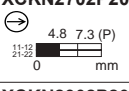

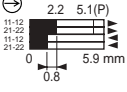
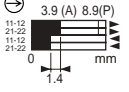
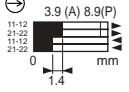
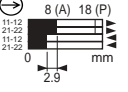
Limit switches

XC Basic range
Compact design, plastic, XCKN
Complete switches with 1 cable entry

Type of head	Plunger (fixing by the body)				
					

Type of operator	Metal end plunger	Plastic roller plunger for lateral cam approach	Plastic roller plunger for traverse cam approach	Thermoplastic roller lever plunger, horizontal actuation in 1 direction	Thermoplastic roller lever plunger, vertical actuation in 1 direction
Sold and packed in lots of	20	20	20	20	20

References of complete switches with 1 ISO M20 x 1.5 cable entry						
	2-pole NC + NO snap action	XCKN2110P20 	XCKN2102P20 	XCKN2103P20 	XCKN2121P20 	XCKN2127P20 
	2-pole NC + NO break before make, slow break	XCKN2510P20 	XCKN2502P20 	XCKN2503P20 	XCKN2521P20 	XCKN2527P20 
	2-pole NC + NC simultaneous, slow break	XCKN2710P20 	XCKN2702P20 	—	XCKN2721P20 	—
	2-pole NC + NC snap action	XCKN2910P20 	XCKN2902P20 	XCKN2903P20 	XCKN2921P20 	—
Weight (kg)	0.065	0.065	0.065	0.070	0.070	
Contact operation	 closed  open	(A) (B) = cam displacement (P) = positive opening point		 NC contact with positive opening operation		

Characteristics					
Switch actuation	On end	By 30° cam			
Type of actuation					
Maximum actuation speed	0.5 m/s	0.3 m/s	1 m/s		
Mechanical durability (in millions of operating cycles)	10				
Minimum force or torque	For tripping	15 N	12 N	6 N	
	For positive opening	30 N	20 N	10 N	
Cable entry	1 entry tapped M20 x 1.5 mm for ISO cable gland, clamping capacity 7 to 13 mm				

References of complete switches with 1 Pg 11 cable entry

For complete switches with 1 Pg 11 cable entry replace P20 by **G11**.
Example: XCKN2110P20 becomes **XCKN2110G11**.

Other cable entries

For complete switches with ISO M16 x 1.5 or PF 1/2 (G 1/2) cable entry, please consult our Customer Care Centre.

Other contacts

For complete switches with 2-pole contacts:
NO + NC make before break, slow break,
NO + NO simultaneous, slow break, please consult our Customer Care Centre.

For complete switches with 3-pole contacts:
NC + NO + NO snap action,
NC + NC + NO snap action,
NC + NC + NO break before make, slow break,
NC + NO + NO break before make, slow break, please consult our Customer Care Centre.

Limit switches

XC Basic range

Compact design, plastic, XCKN

Complete switches with 1 cable entry

Type of head	Rotary (fixing by the body)				Multi-directional	
Type of operator	Thermoplastic roller lever	Variable length thermoplastic roller lever	Thermoplastic roller lever, Ø 50 mm	Variable length thermoplastic roller lever, Ø 50 mm	Spring rod	"Cat's whisker"
Sold and packed in lots of	20	20	20	20	20	20

References of complete switches with 1 ISO M20 x 1.5 cable entry

	XCKN2118P20	XCKN2145P20	XCKN2139P20	XCKN2149P20	XCKN2108P20	XCKN2106P20
 2-pole NC + NO snap action						
 2-pole NC + NO break before make, slow break						
 2-pole NC + NC simultaneous, slow break						
 2-pole NC + NC snap action						
Weight (kg)	0.085	0.090	0.110	0.115	0.085	0.075
Contact operation			(A) (B) = cam displacement (P) = positive opening point			

Characteristics

Switch actuation	By 30° cam	By any moving part
Type of actuation		
Maximum actuation speed	1.5 m/s	1 m/s (any direction)
Mechanical durability	10 million operating cycles	5 million operating cycles
Minimum force or torque	For tripping: 0.1 N.m For positive opening: 0.15 N.m	0.13 N.m
Cable entry	1 entry tapped M20 x 1.5 mm for ISO cable gland, clamping capacity 7 to 13 mm	

References of complete switches with 1 Pg 11 cable entry

For complete switches with 1 Pg 11 cable entry replace P20 by G11.
Example: XCKN2118P20 becomes XCKN2118G11.

Other cable entries

For complete switches with ISO M16 x 1.5 or PF 1/2 (G 1/2) cable entry, please consult our Customer Care Centre.

Other contacts

For complete switches with 2-pole contacts:
NO + NC make before break, slow break,
NO + NO simultaneous, slow break, please consult our Customer Care Centre.





For complete switches with 3-pole contacts:
NC + NO + NO snap action,
NC + NC + NO snap action,
NC + NC + NO break before make, slow break,
NC + NO + NO break before make, slow break, please consult our Customer Care Centre.

Limit switches

XC Basic range

Compact design, plastic, XCNT



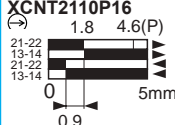
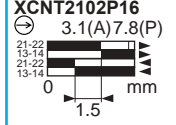
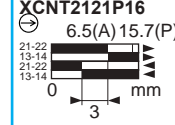
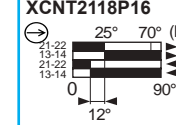

Complete switches with 2 cable entries

Type of head	Plunger (fixing by the body)			Rotary (fixing by the body)
				
Type of operator	Metal end plunger	Plastic roller plunger for lateral cam approach	Thermoplastic roller lever plunger, horizontal actuation in 1 direction	Thermoplastic roller lever
Sold and packed in lots of	10	10	10	

References of complete switches with 2 ISO M16 x 1.5 cable entries

 <p>2-pole NC + NO snap action</p>	<p>XCNT2110P16</p>  <p>1.8 4.6(P) 21-22 13-14 13-14 0 5mm 0.9</p>	<p>XCNT2102P16</p>  <p>3.1(A) 7.8(P) 21-22 13-14 13-14 0 1.5</p>	<p>XCNT2121P16</p>  <p>6.5(A) 15.7(P) 21-22 13-14 13-14 0 3</p>	<p>XCNT2118P16</p>  <p>25° 70° (P) 21-22 13-14 13-14 0 12° 90°</p>
	<p>Weight (kg)</p> <p>0.085</p>	<p>0.085</p>	<p>0.090</p>	<p>0.105</p>
Contact operation	<p>■ closed (A) (B) = cam displacement □ open (P) = positive opening point</p>			<p>⊖ NC contact with positive opening operation</p>

Characteristics

Switch actuation	On end	By 30° cam			
Type of actuation					
Maximum actuation speed	0.5 m/s	0.3 m/s	1 m/s	1.5 m/s	
Mechanical durability (in millions of operating cycles)	10				
Minimum force or torque	For tripping	15 N	12 N	6 N	0.1 N.m
	For positive opening	30 N	20 N	10 N	0.15 N.m
Cable entry	2 entries tapped M16 x 1.5 mm for ISO cable gland, clamping capacity 4 to 8 mm				

References of complete switches with 2 Pg 11 cable entries

For complete switches with 2 Pg 11 cable entries replace P16 by G11.
Example: XCNT2110P16 becomes XCNT2110G11.

Complete switches with 1/2" NPT cable entry

For complete switches with 1/2" NPT cable entry use adaptor DE9 RA1012 (compatible with XCNT●●●●G11).



DE9RA1012

Description	Sold in lots of	Unit reference	Weight kg
Adaptor for 1/2" NPT conduit (male Pg 11 / female 1/2" NPT)	10	DE9RA1012	0.050

Other contacts

For complete switches with 2-pole contacts:
NO + NC make before break, slow break,
NO + NO simultaneous, slow break, please consult our Customer Care Centre.

Limit switches

XC Basic range

Compact design, plastic, XCKN

Complete switches with 1 cable entry

Dimensions

XCKN2●10P20

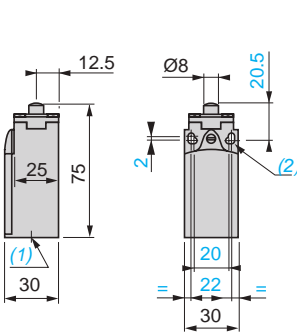

XCKN2●02P20

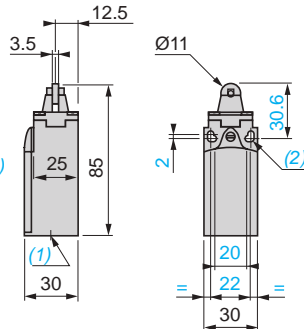

XCKN2●03P20

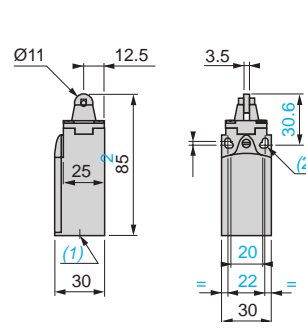

XCKN2●21P20

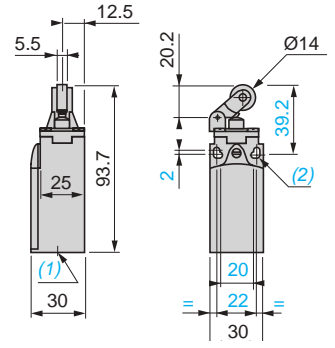

XCKN2●27P20

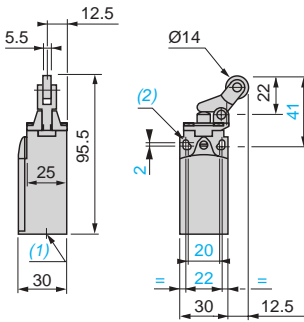

XCKN2●18P20

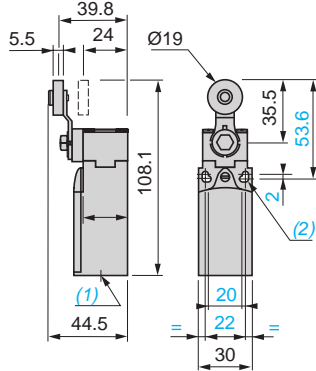

XCKN2●45P20

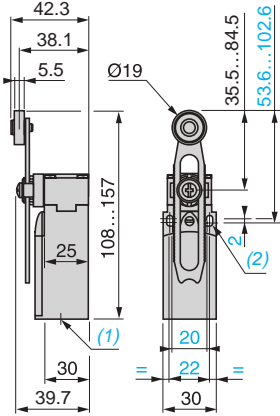

XCKN2●39P20

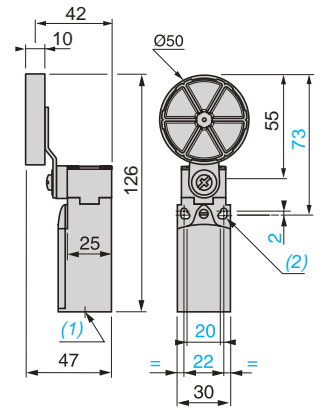

XCKN2●49P20

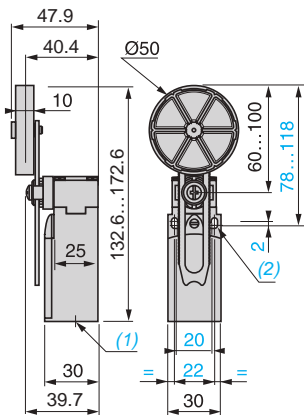

XCKN2●08P20

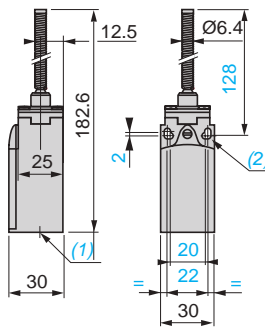

XCKN2●06P20

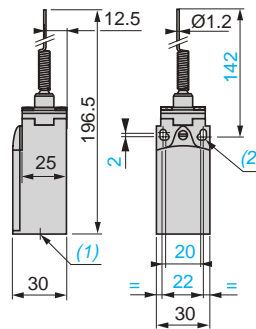

(1) 1 tapped entry for ISOM20 x 1.5 or Pg 11 cable gland.
(2) Ø: 2 elongated holes Ø 4.3 x 6.3 on 22 mm centres, 2 holes Ø 4.3 on 20 mm centres.

XCNT2●10P16

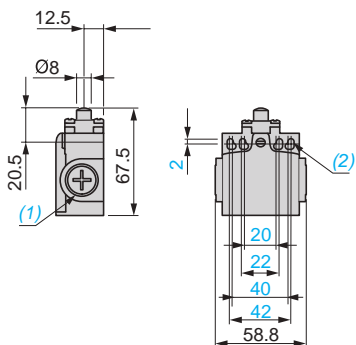

XCNT2●02P16

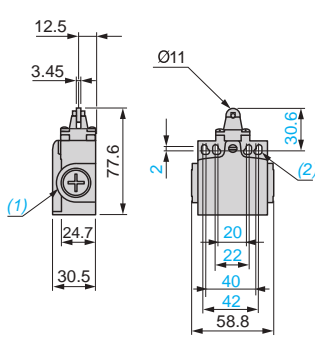

XCNT2●21P16

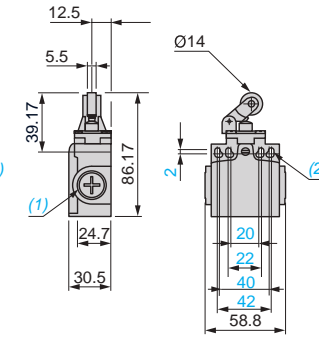

XCNT2●18P16

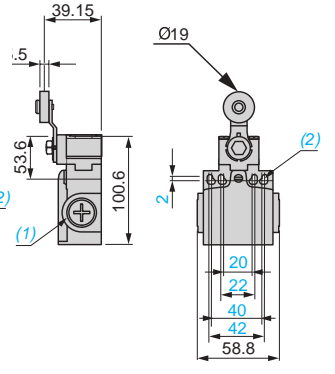

Limit switches

XC Basic range

Compact design, plastic, with reset knob, XCNR

Complete switches with 1 cable entry

■ XCNR
with 1 cable entry

□ With head for linear movement (plunger)

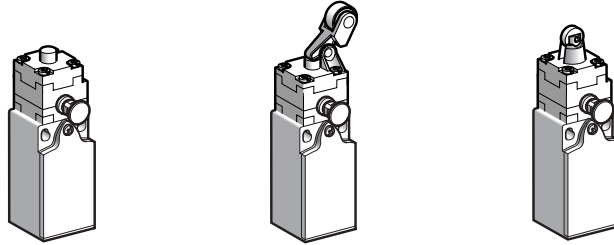

Page 112

□ With head for rotary movement (lever)

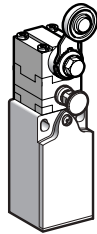

Page 112

Environment characteristics		
Conformity to standards	Products	CE, IEC 60947-5-1, EN 60947-5-1, UL 508, CSA C22-2 n° 14, EAC
	Machine assemblies	IEC 60204-1, EN 60204-1
Product certifications		UL, CSA, CCC
Protective treatment	Version	Standard: "TC"
Ambient air temperature	For operation	- 25...+ 70°C
	For storage	- 40...+ 70°C
Vibration resistance	Conforming to IEC 60068-2-6	25 gn (10...500 Hz)
Shock resistance	Conforming to IEC 60068-2-27	50 gn (11 ms)
Electric shock protection		Class II conforming to IEC 61140 and NF C 20030
Degree of protection		IP 65 conforming to IEC 60529; IK 04 conforming to IEC 62262
Cable entry		Depending on model: tapped entry, for ISO M20 x 1.5 or Pg 11 cable gland, ISO M16 x 1.5 cable gland or PF 1/2 (G 1/2)
Materials	Bodies	Plastic
	Heads	Plastic
Contact block characteristics		
Rated operational characteristics		~ AC-15; A300 (U _e = 240 V, I _e = 3 A); I _{the} = 10 A ≡ DC-13; R300 (U _e = 250 V, I _e = 0.1 A), conforming to IEC 60947-5-1 Appendix A, EN 60947-5-1
Rated insulation voltage	2-pole contact	U _i = 500 V degree of pollution 3 conforming to IEC 60947-1 U _i = 300 V conforming to UL 508, CSA C22-2 n° 14
Rated impulse withstand voltage	2-pole contact	U _{imp} = 6 kV conforming to IEC 60947-1, IEC 60664
Positive operation		NC contacts with positive opening operation conforming to IEC 60947-5-1 Appendix K, EN 60947-5-1
Short-circuit protection		10 A cartridge fuse type gG (gl)
Connection	Screw clamp terminals	Clamping capacity, min: 1 x 0.34 mm ² , max: 2 x 1.5 mm ²









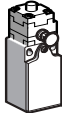
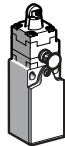
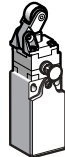
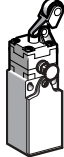
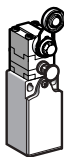

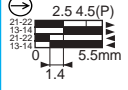
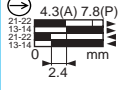
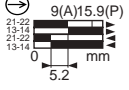
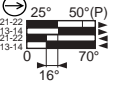

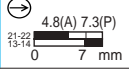
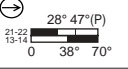

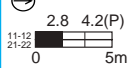
Limit switches



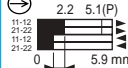
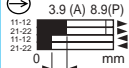
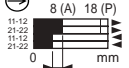

XC Basic range

Compact design, plastic, with reset knob, XCNR

Complete switches with 1 cable entry

Type of head	Plunger (fixing by the body)					Rotary (fixing by the body)
						
Type of operator	Metal end plunger	Plastic roller plunger	Thermoplastic roller lever plunger, horizontal actuation in 1 direction	Thermoplastic roller lever plunger, vertical actuation in 1 direction	Thermoplastic roller lever	
Sold and packed in lots of	10	10	10	10	10	

References of complete switches with 1 ISO M20 x 1.5 cable entry						
	2-pole NC + NO snap action	XCNR2110P20 	XCNR2102P20 	XCNR2121P20 	–	XCNR2118P20 
	2-pole NC + NO break before make, slow break	–	XCNR2502P20 	–	–	XCNR2518P20 
	2-pole NC + NC simultaneous, slow break	XCNR2710P20 	XCNR2702P20 	XCNR2721P20 	–	–
	2-pole NC + NC snap action	XCNR2910P20 	XCNR2902P20 	XCNR2921P20 	XCNR2927P20 	XCNR2918P20 
Weight (kg)		0.080	0.080	0.085	0.090	0.100
Contact operation		 closed  open	(A) (B) = cam displacement (P) = positive opening point		 NC contact with positive opening operation	

Characteristics						
Switch actuation	On end		By 30° cam			
Type of actuation						
Maximum actuation speed	0.5 m/s	0.3 m/s	1 m/s			1.5 m/s
Mechanical durability	100,000 operating cycles					
Minimum force or torque	For tripping	15 N	12 N	6 N		0.1 N.m
	For positive opening	30 N	20 N	10 N		0.15 N.m
Cable entry	1 entry tapped M20 x 1.5 mm for ISO cable gland, clamping capacity 7 to 13 mm					

References of complete switches with 1 Pg 11 cable entry

For complete switches with 1 Pg 11 cable entry replace P20 by G11.
Example: XCNR2110P20 becomes XCNR2110G11.

Other cable entries

For complete switches with ISO M16 x 1.5 or PF 1/2 (G 1/2) cable entry, please consult our Customer Care Centre.

Other contacts

For complete switches with 2-pole contacts:
NC + NO make before break, slow break,
NO + NO simultaneous, slow break, please consult our Customer Care Centre.

For complete switches with 3-pole contacts:
NC + NO + NO snap action,
NC + NC + NO snap action,
NC + NC + NO break before make, slow break,
NC + NO + NO break before make, slow break, please consult our Customer Care Centre.

Limit switches

XC Basic range

Compact design, plastic, with reset knob, XCNR

Complete switches with 1 cable entry

Dimensions

XCNR2●10P20

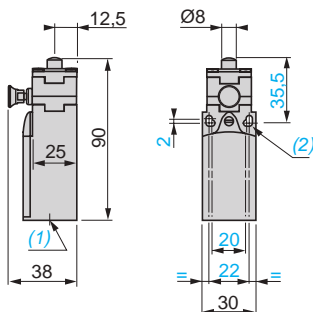

XCNR2●02P20

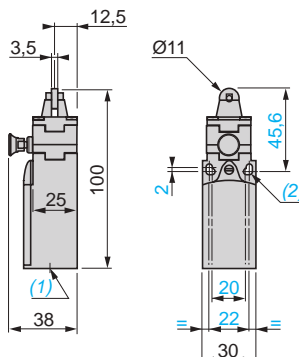

XCNR2●21P20

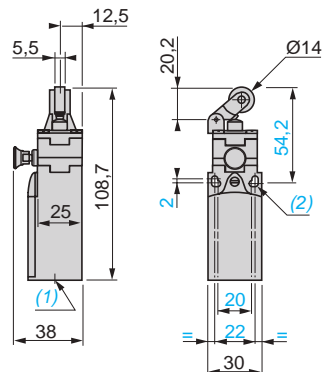

XCNR2●27P20

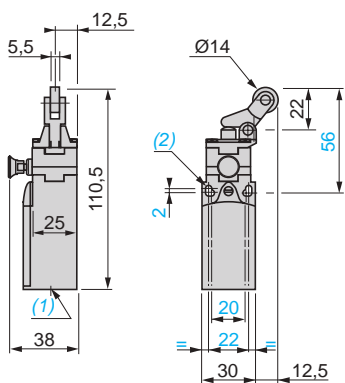

XCNR2●18P20

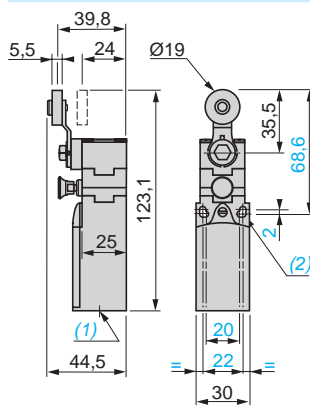

(1) 1 tapped entry for ISO M20 x 1.5 or Pg 11 cable gland.

(2) Ø: 2 elongated holes Ø 4.3 x 6.3 on 22 mm centres, 2 holes Ø 4.3 on 20 mm centres.

Limit switches

XC Standard range, Classic format
Metal, XCKM, XCKL and XCKML

■ XCKM,
with 3 cable entries

□ With head for linear movement
(plunger)

□ With head for rotary movement
(lever) or multi-directional

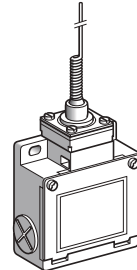
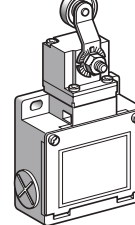
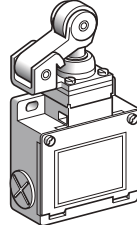
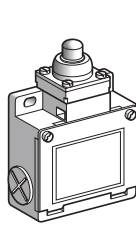

Page 116

■ XCKL,
with 1 cable entry

□ With head for linear movement
(plunger)

□ With head for rotary movement
(lever) or multi-directional

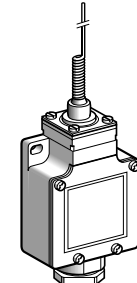
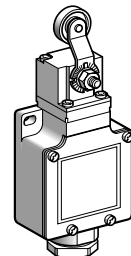
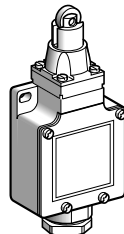
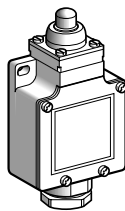

Page 118

■ XCKML,
with 3 cable entries and 2 x 2-pole contacts

□ With head for linear movement
(plunger)

□ With head for rotary movement
(lever)

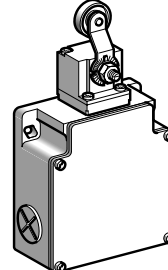
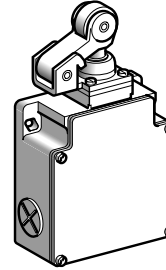
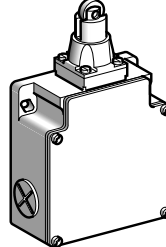
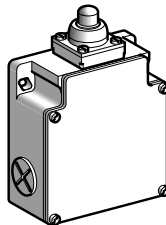

Page 120

Environment characteristics

Conformity to standards	Products	IEC 60947-5-1, EN 60947-5-1, UL 508, CSA C22-2 n° 14
	Machine assemblies	IEC 60204-1, EN 60204-1
Product certifications		UL, CSA CCC (only for XCKM) BV (only for XCKM and XCKL)
Protective treatment	Version	Standard: "TC". Special: "TH"
Ambient air temperature	For operation	- 25...+ 70°C
	For storage	- 40...+ 70°C
Vibration resistance	Conforming to IEC 60068-2-6	25 gn (10...500 Hz)
Shock resistance	Conforming to IEC 60068-2-27	50 gn (11 ms)
Electric shock protection		Class I conforming to IEC 61140 and NF C 20-030
Degree of protection		IP 66 conforming to IEC 60529; IK 05 conforming to IEC 62262
Repeat accuracy		XCKML 0.1 mm; XCKM and XCKL 0.05 mm on the tripping points, with 1 million operating cycles for head with end plunger
Cable entry or connector	Depending on model	XCKM: 3 tapped entries for Pg 11 cable gland or tapped ISO M20, or with 1/2" NPT adaptor XCKL: 1 tapped entry incorporating Pg 13.5 cable gland or 1 entry tapped 1/2" NPT XCKML: 3 tapped entries for Pg 13.5 cable gland or tapped ISO M20
Materials		Bodies: Zamak. Rotary heads: Zamak or plastic, depending on product reference. Other heads: plastic

Contact block characteristics		
Rated operational characteristics	XE2●P	~ AC-15; A300 (Ue = 240 V, Ie = 3 A); Ithe = 10 A --- DC-13; Q300 (Ue = 250 V, Ie = 0.27 A), conforming to IEC 60947-5-1 Appendix A, EN 60947-5-1
	XE3●P	~ AC-15; B300 (Ue = 240 V, Ie = 1.5 A); Ithe = 6 A --- DC-13; R300 (Ue = 250 V, Ie = 0.1 A), conforming to IEC 60947-5-1 Appendix A, EN 60947-5-1
Rated insulation voltage	XE2●P	Ui = 500 V degree of pollution 3 conforming to IEC 60947-1 Ui = 300 V conforming to UL 508, CSA C22-2 n° 14
	XE3●P	Ui = 400 V degree of pollution 3 conforming to IEC 60947-1 Ui = 300 V conforming to UL 508, CSA C22-2 n° 14
Rated impulse withstand voltage	XE2●P	U imp = 6 kV conforming to IEC 60947-1, IEC 60664
	XE3●P	U imp = 4 kV conforming to IEC 60947-1, IEC 60664
Positive operation (depending on model)		NC contacts with positive opening operation conforming to IEC 60947-5-1 Appendix K, EN 60947-5-1
Resistance across terminals		≤ 25 mΩ conforming to IEC 60255-7 category 3
Short-circuit protection	XE2●P	10 A cartridge fuse type gG (gl)
	XE3●P	6 A cartridge fuse type gG (gl)
Connection (screw clamp terminals)	XE2SP21●1	Clamping capacity, min: 1 x 0.34 mm ² , max: 2 x 1.5 mm ²
	XE2NP21●1	Clamping capacity, min: 1 x 0.5 mm ² , max: 2 x 2.5 mm ²
	XESP2151L and XENP2151L	Clamping capacity, min: 1 x 0.34 mm ² , max: 2 x 1.5 mm ² or 1 x 2.5 mm ²
	XE3NP and XE3SP	Clamping capacity, min: 1 x 0.34 mm ² , max: 1 x 1 mm ² or 2 x 0.75 mm ²
Minimum actuation speed		XE2SP21●1, XESP2151L and XE3SP: 0.01 m/minute XE2NP21●1, XENP2151L and XE3NP: 6 m/minute
Electrical durability		<ul style="list-style-type: none"> ■ Conforming to IEC 60947-5-1 Appendix C ■ Utilisation categories AC-15 and DC-13 ■ Maximum operating rate: 3600 operating cycles/hour ■ Load factor: 0.5

AC supply
50/60 Hz ~
mm inductive circuit

XE2SP21●1, XE2SP2141, XESP2151L

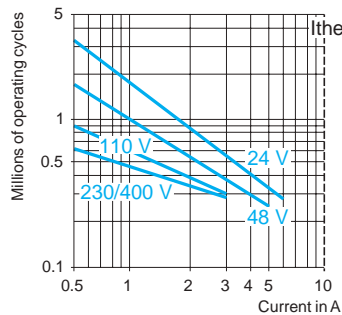

XE2NP21●1, XENP2151L

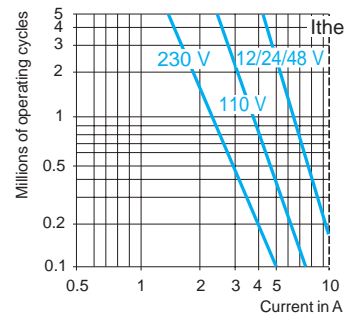

DC supply ---

Power broken in W for 5 million operating cycles.

Voltage	V	24	48	120
mm	W	10	7	4

Power broken in W for 5 million operating cycles.

Voltage	V	24	48	120
mm	W	13	9	7

For XE2SP●151 on ~ or ---, NC and NO contacts simultaneously loaded to the values shown with reverse polarity.

AC supply
50/60 Hz ~
mm inductive circuit

XE3SP●●●●

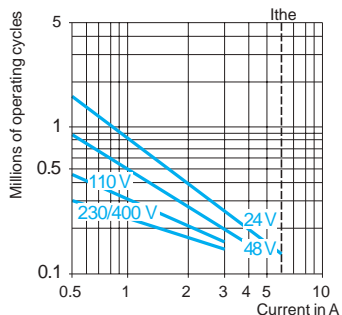

XE3NP●●●●

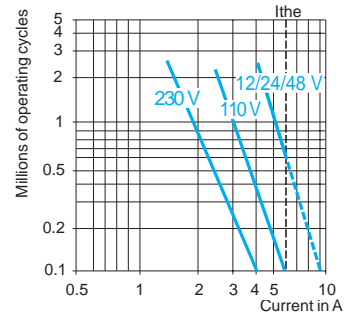

DC supply ---

Power broken in W for 5 million operating cycles.

Voltage	V	24	48	120
mm	W	3	2	1

Power broken in W for 5 million operating cycles.







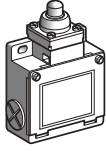
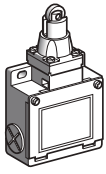
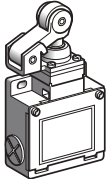
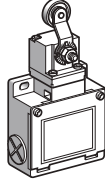
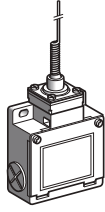

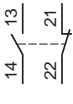
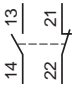
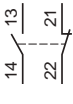
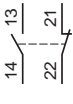
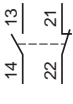

Voltage	V	24	48	120
mm	W	4	3	2

Limit switches



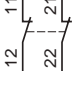
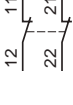
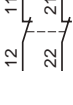
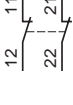
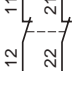
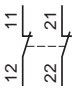
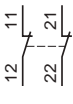
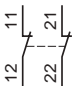
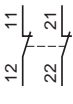
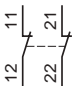
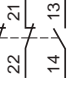
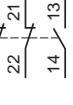
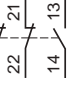
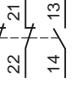
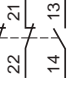
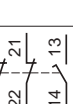
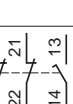
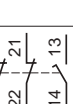
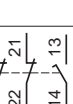
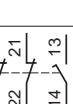

XC Standard range, Classic format
Metal, XCKM
Complete units with 3 cable entries

Type of head	Plunger (fixing by the body)	Rotary (fixing by the body)	Multi-directional, (fixing by the body)
			
			

Type of operator	Metal end plunger	Steel roller plunger	Thermoplastic roller lever plunger, horizontal actuation in 1 direction	Thermoplastic roller lever (1)	"Cat's whisker" (2)
------------------	-------------------	----------------------	---	--------------------------------	---------------------

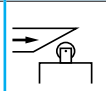
References of complete units with 3 ISO M20 x 1.5 cable entries (3)					
2-pole NC + NO snap action (XE2SP2151)	 XCKM110H29	 XCKM102H29	 XCKM121H29	 XCKM115H29	 XCKM106H29
2-pole NC + NO break before make, slow break (XE2NP2151)	 XCKM510H29	 XCKM502H29	 XCKM521H29	 XCKM515H29	 XCKM506H29
2-pole NC + NC snap action (XE2SP2141)	 ZCKM9H29 + ZCKD10	 ZCKM9H29 + ZCKD02	 ZCKM9H29 + ZCKD21	 ZCKM9H29 + ZCKD15	 ZCKM9H29 + ZCKD06
2-pole NC + NC simultaneous, slow break (XE2NP2141)	 ZCKM7H29 + ZCKD10	 ZCKM7H29 + ZCKD02	 ZCKM7H29 + ZCKD21	 ZCKM7H29 + ZCKD15	 ZCKM7H29 + ZCKD06
3-pole NC + NC + NO snap action (XE3SP2141)	 ZCKMD39H29 + ZCKD10	 ZCKMD39H29 + ZCKD02	 ZCKMD39H29 + ZCKD21	 ZCKMD39H29 + ZCKD15	 ZCKMD39H29 + ZCKD06
3-pole NC + NC + NO break before make, slow break (XE3NP2141)	 ZCKMD37H29 + ZCKD10	 ZCKMD37H29 + ZCKD02	 ZCKMD37H29 + ZCKD21	 ZCKMD37H29 + ZCKD15	 ZCKMD37H29 + ZCKD06
Weight (kg)	0.250	0.255	0.300	0.280	0.250
Contact operation	 closed  open	(A) = cam displacement (P) = positive opening point		 NC contact with positive opening operation	

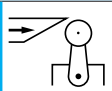
References of complete units with 3 Pg 11 cable entries
For complete units with 3 Pg 11 cable entries, delete H29 from the end of the reference. Example: XCKM110H29 becomes XCKM110.

Characteristics					
Switch actuation	On end	By 30° cam			By any moving part
Type of actuation					
Maximum actuation speed	0.5 m/s	1.5 m/s			1 m/s (any direction)
Mechanical durability (4) (in millions of operating cycles)	20	15			10
Minimum force or torque	For tripping: 15 N For positive opening: 45 N	12 N 36 N	8 N 24 N	0.1 N.m 0.25 N.m	0.13 N.m -
Cable entry	3 entries tapped M20 x 1.5 mm for ISO cable gland, clamping capacity 7 to 13 mm				

(1) Adjustable throughout 360° in 5° steps, or in 90° steps by reversing the notched washer.
(2) Value taken with actuation by moving part at 100 mm from the fixing.
(3) Switches with gold contacts or eyelet type connections: please consult our Customer Care Centre.
(4) Limited to 15 million operating cycles for switches with contacts XE3●P.

Limit switches

XC Standard range, Classic format

Metal, XCKM

Complete units with 3 cable entries

XCKM●10
ZCKMD3● + ZCKD10

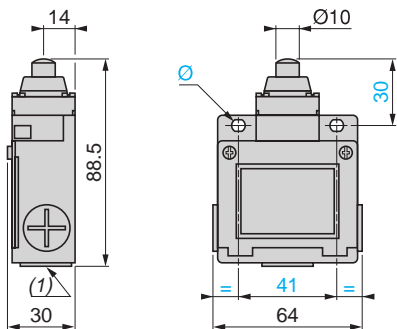

XCKM●02
ZCKMD3● + ZCKD02

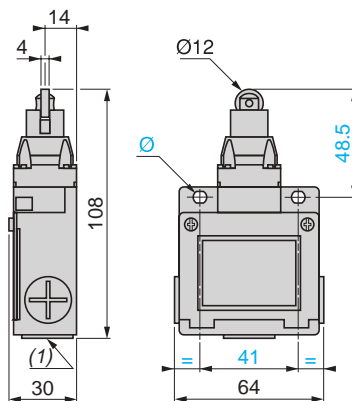

XCKM●21
ZCKMD3● + ZCKD21

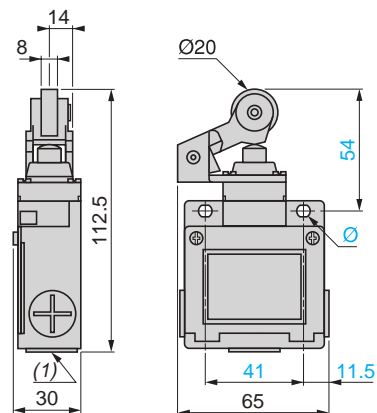

XCKM●15
ZCKMD3● + ZCKD15

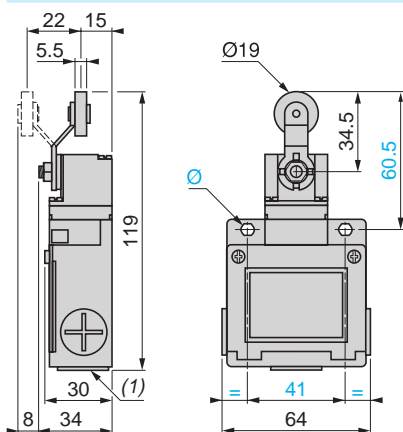

XCKM●06
ZCKMD3● + ZCKD06

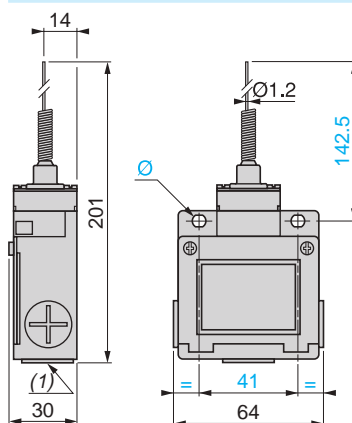

Rear view XCKM●●●, ZCKM●, ZCKMD3●

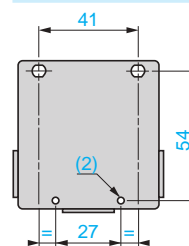

(1) 3 tapped entries for ISO M20 x 1.5 or Pg 11 cable gland or with 1/2" NPT conduit adaptor DE9RA1012.

(2) 2 x Ø 4 H 11, depth 10.

Ø: 2 elongated holes Ø 5.2 x 6.2

Adaptor for 1/2" NPT conduit
DE9RA1012

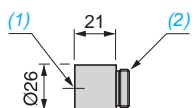







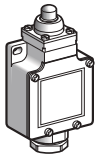
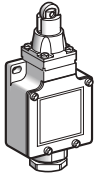
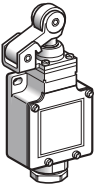
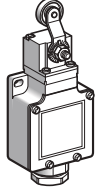
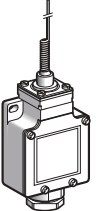

(1) Tapped entry for 1/2" NPT conduit.

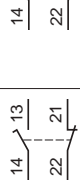
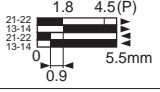
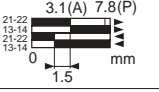
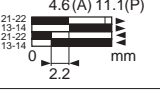
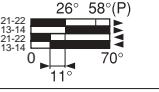
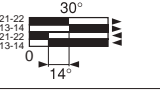
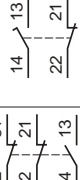

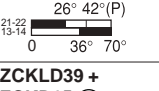
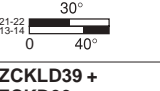
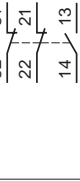

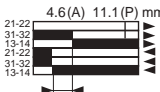
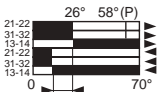
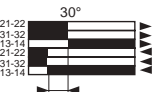
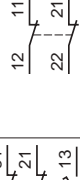
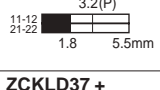
(2) Pg 11 threaded sleeve.

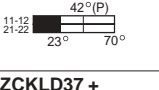
Limit switches

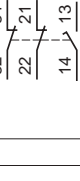
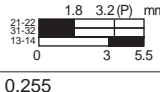
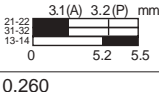
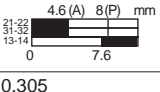
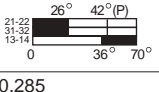
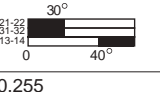
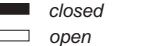
XC Standard range, Classic format
Metal, XCKL
Complete units incorporating Pg 13.5 cable gland

Type of head	Plunger (fixing by the body)			Rotary (fixing by the body)	Multi-directional, (fixing by the body)
					
Type of operator	Metal end plunger	Steel roller plunger	Thermoplastic roller lever plunger, horizontal actuation in 1 direction	Thermoplastic roller lever (1)	"Cat's whisker" (2)

References (3)						
2-pole NC + NO snap action (XE2SP2151)		XCKL110 ⊕ 	XCKL102 ⊕ 	XCKL121 ⊕ 	XCKL115 ⊕ 	XCKL106 
2-pole NC + NO break before make, slow break (XE2NP2151)		-	-	XCKL521 ⊕ 	XCKL515 ⊕ 	XCKL506 
3-pole NC + NC + NO snap action (XE3SP2141)		ZCKLD39 + ZCKD10 ⊕ 	ZCKLD39 + ZCKD02 ⊕ 	ZCKLD39 + ZCKD21 ⊕ 	ZCKLD39 + ZCKD15 ⊕ 	ZCKLD39 + ZCKD06 
2-pole NC + NC simultaneous, slow break (XE2NP2141)		ZCKL7 + ZCKD10 ⊕ 	ZCKL7 + ZCKD02 ⊕ 	ZCKL7 + ZCKD21 ⊕ 	ZCKL7 + ZCKD15 ⊕ 	ZCKL7 + ZCKD06 
3-pole NC + NC + NO break before make, slow break (XE3NP2141)		ZCKLD37 + ZCKD10 ⊕ 	ZCKLD37 + ZCKD02 ⊕ 	ZCKLD37 + ZCKD21 ⊕ 	ZCKLD37 + ZCKD15 ⊕ 	ZCKLD37 + ZCKD06 
Weight (kg)	0.255	0.260	0.305	0.285	0.255	
Contact operation			(A) = cam displacement (P) = positive opening point	⊕ NC contact with positive opening operation		

Characteristics						
Switch actuation	On end	By 30° cam			By any moving part	
Type of actuation						
Maximum actuation speed	0.5 m/s	1.5 m/s			1 m/s (any direction)	
Mechanical durability (4) (in millions of operating cycles)	20	15			10	
Minimum force or torque	For tripping For positive opening	15 N 45 N	12 N 36 N	8 N 24 N	0.1 N.m 0.25 N.m	0.13 N.m -
Cable entry	1 entry incorporating metal cable gland. Clamping capacity 6 to 13.5 mm.					

(1) Adjustable throughout 360° in 5° steps, or in 90° steps by reversing the notched washer.
 (2) Value taken with actuation by moving part at 100 mm from the fixing.
 (3) Switches with gold contacts or eyelet type connections: please consult our Customer Care Centre.
 (4) Limited to 15 million operating cycles for switches with contacts XE3●P.

Limit switches

XC Standard range, Classic format

Metal, XCKL

Complete units incorporating Pg 13.5 cable gland

XCKL●10
ZCKL● + ZCKD10
ZCKLD3● + ZCKD10

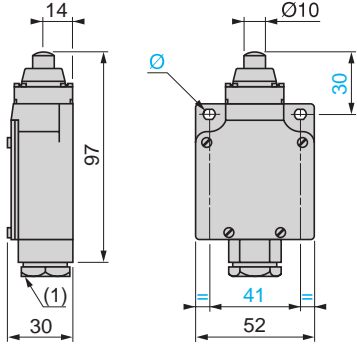

XCKL●02
ZCKL3● + ZCKD02
ZCKLD3● + ZCKD02

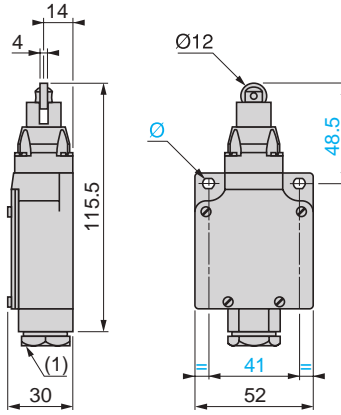

XCKL●21
ZCKL● + ZCKD21
ZCKLD3● + ZCKD21

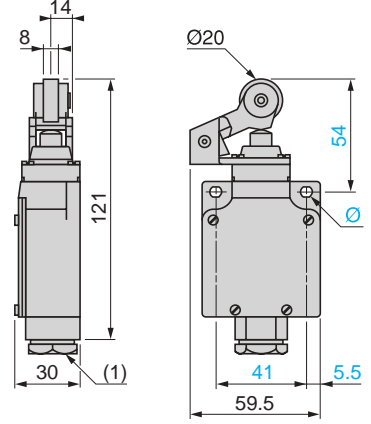

XCKL●15
ZCKL● + ZCKD15
ZCKLD3● + ZCKD15

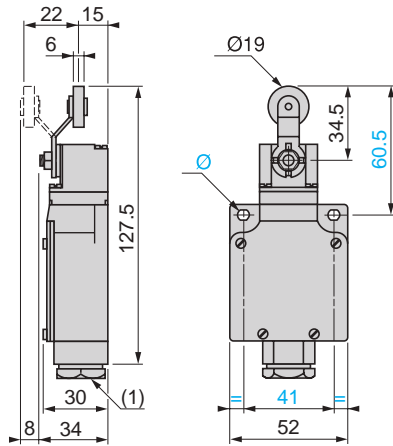

XCKL●06
ZCKL● + ZCKD06
ZCKLD3● + ZCKD06

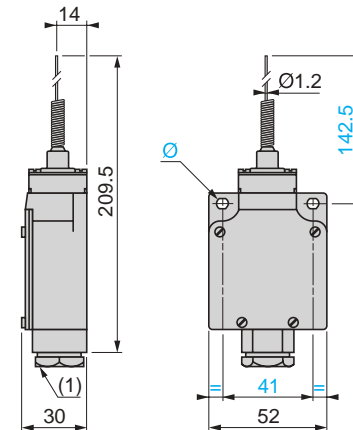

Body fixings

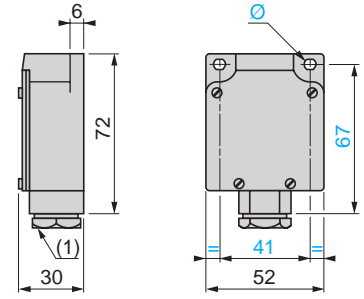

(1) Incorporated Pg 13.5 cable gland
Ø: 2 elongated holes Ø 5.2 x 6.2

Limit switches

XC Standard range, Classic format
Metal, 2 x 2-pole contacts, XCKML
Complete switches with 3 cable entries

Type of head	Plunger (fixing by the body)	Rotary (fixing by the body)		
--------------	------------------------------	-----------------------------	--	--

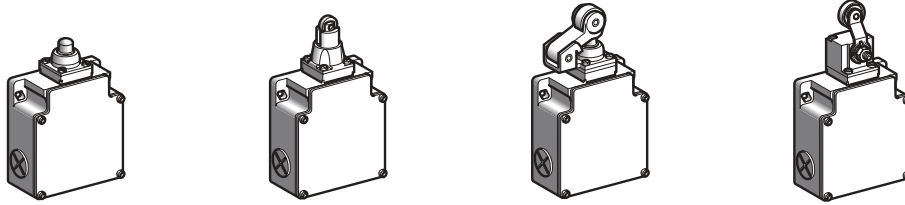

Type of operator	Metal end plunger	Steel roller plunger	Thermoplastic roller lever plunger, horizontal actuation in 1 direction	Thermoplastic roller lever (1)
------------------	-------------------	----------------------	---	--------------------------------

References of complete switches with 3 ISO M20 x 1.5 cable entries (2)

2 x 2-pole NC + NO snap action (XESP2151L) 	XCKML110H29	XCKML102H29	XCKML121H29	XCKML115H29
2 x 2-pole NC + NO break before make, slow break (XENP2151L) 	—	XCKML502H29	—	—

References of complete switches with 3 entries tapped for n° 13 cable gland (2)

2 x 2-pole NC + NO snap action (XESP2151L) 	XCKML110	XCKML102	XCKML121	XCKML115
2 x 2-pole NC + NO break before make, slow break (XENP2151L) 	—	XCKML502	—	XCKML515
Weight (kg)	0.400	0.405	0.450	0.430
Contact operation	closed open	(A) = cam displacement (P) = positive opening point	NC contact with positive opening operation	

Characteristics

Switch actuation	On end	By 30° cam		
Type of actuation				
Maximum actuation speed	0.5 m/s	1.5 m/s		
Mechanical durability	3 million operating cycles			
Minimum force	For tripping For positive opening	15 N 60 N	12 N 50 N	8 N 50 N
Cable entry	3 entries tapped ISO M20 x 1.5, clamping capacity 7 to 13 mm, or 3 entries tapped for n° 13 cable gland conforming to NF C 68-300 (DIN Pg 13.5), clamping capacity 9 to 12 mm.			

(1) Adjustable throughout 360° in 5° steps, or in 90° steps by reversing the notched washer.
 (2) Switches available with other 2-pole slow break contact blocks: NO + NC make before break, NC + NC simultaneous (with positive opening operation), NO + NO simultaneous. Please consult our Customer Care Centre.

Note: replacement parts

The heads of limit switches XCKML are the same as those for XCKM and XCKL (see heads ZCKD10, ZCKD02, ZCKD21 and ZCKD15 on page 122).

Limit switches

XC Standard range, Classic format

Metal, 2 x 2-pole contacts, XCKML

Complete switches with 3 cable entries

XCKML110H29, XCKML110

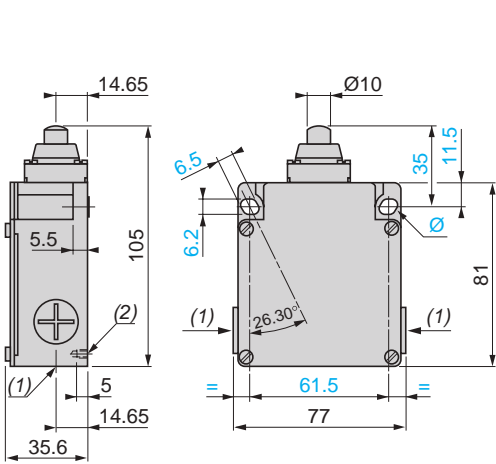

XCKML102H29, XCKML502H29, XCKML102, XCKML502

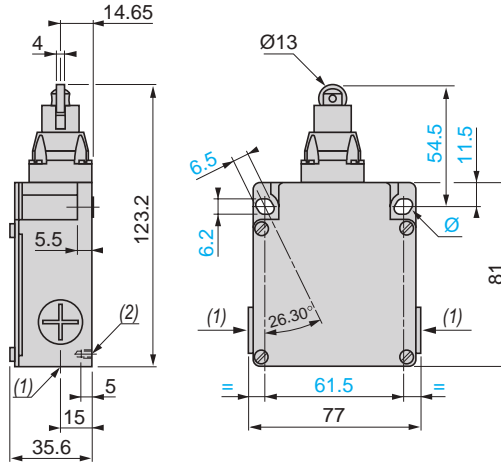

XCKML121H29, XCKML121

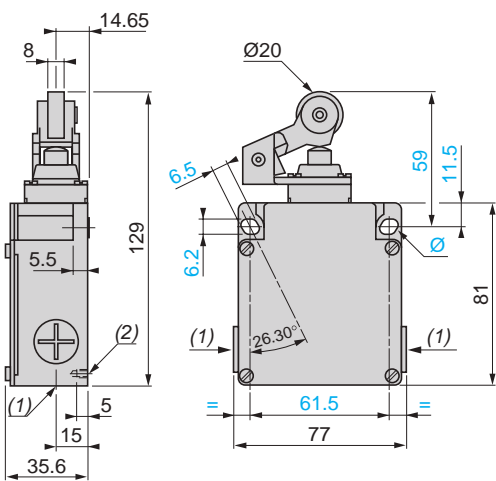

XCKML115H29, XCKML115, XCKML515

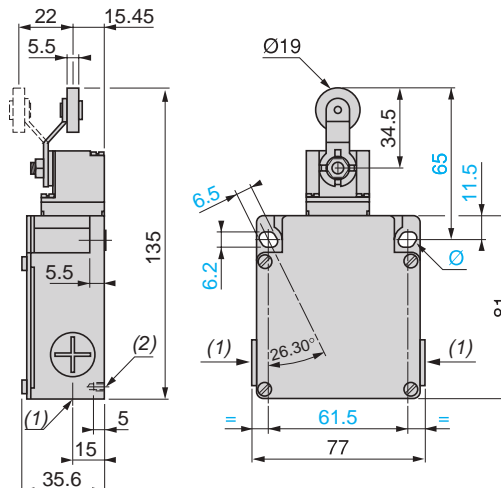

(1) XCKML●●●H29: 3 entries tapped M20 x 1.5. XCKML●●●: 3 tapped entries for n° 13 cable gland.

(2) 2 centring holes Ø 3.9 ± 0.2, for cover fixing holes alignment.

Ø 2 elongated holes 6.2 x 6.5, inclined at 26° 30' to the vertical axis, for M5 screws.

Limit switches

XC Standard range, Classic format
Metal, XCKM and XCKL
Variable composition

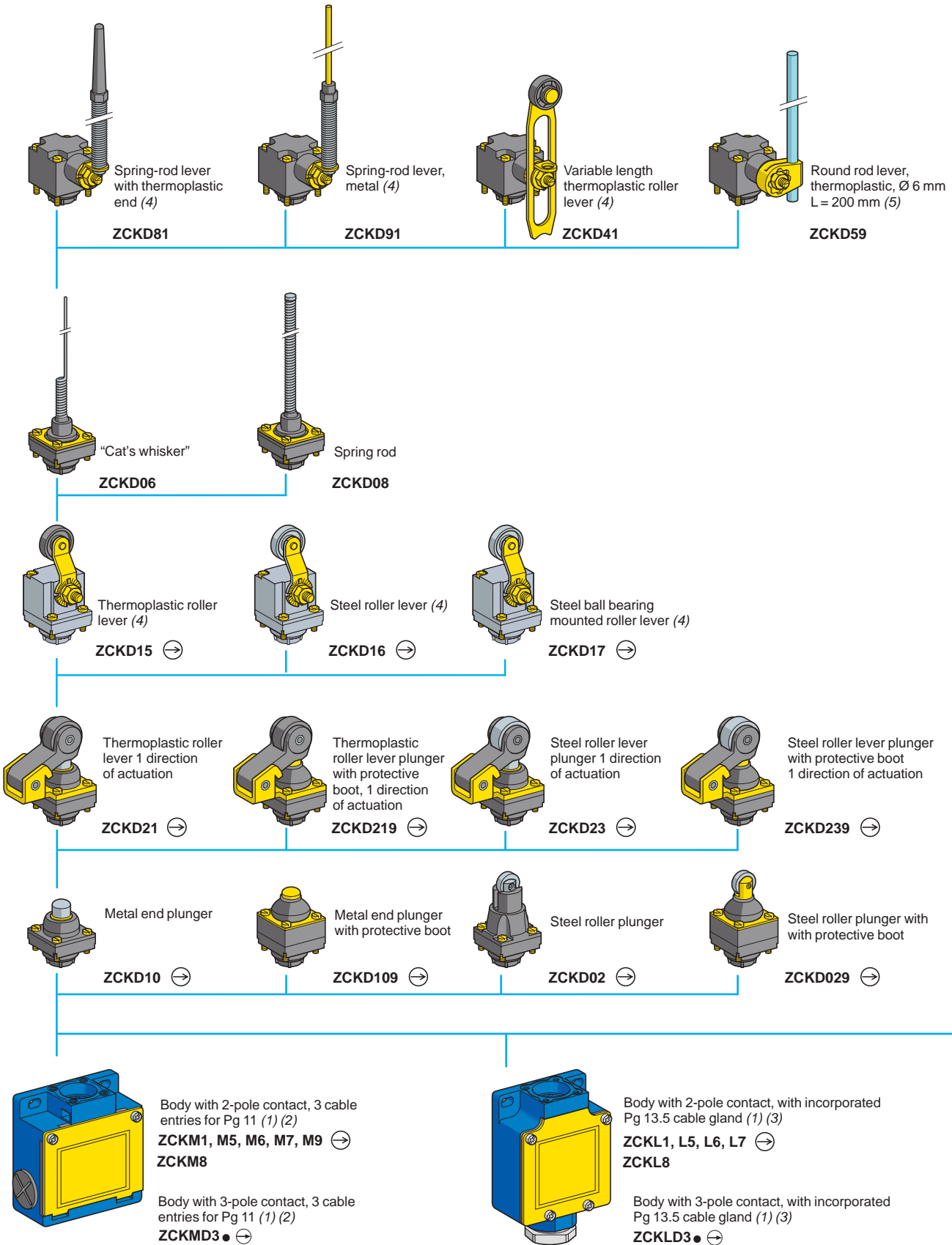

(1) For further information, see page 124.

(2) For 3 cable entries tapped ISO M20 x 1.5, add **H29** to the reference. Example: ZCKM1 becomes **ZCKM1H29**.

For one cable entry with 1/2" NPT adaptor, add **H7** to the reference. Example: ZCKM1 becomes **ZCKM1H7**.

(3) For one cable entry tapped 1/2" NPT, add **H7** to the reference. Example: ZCKL1 becomes **ZCKL1H7**.

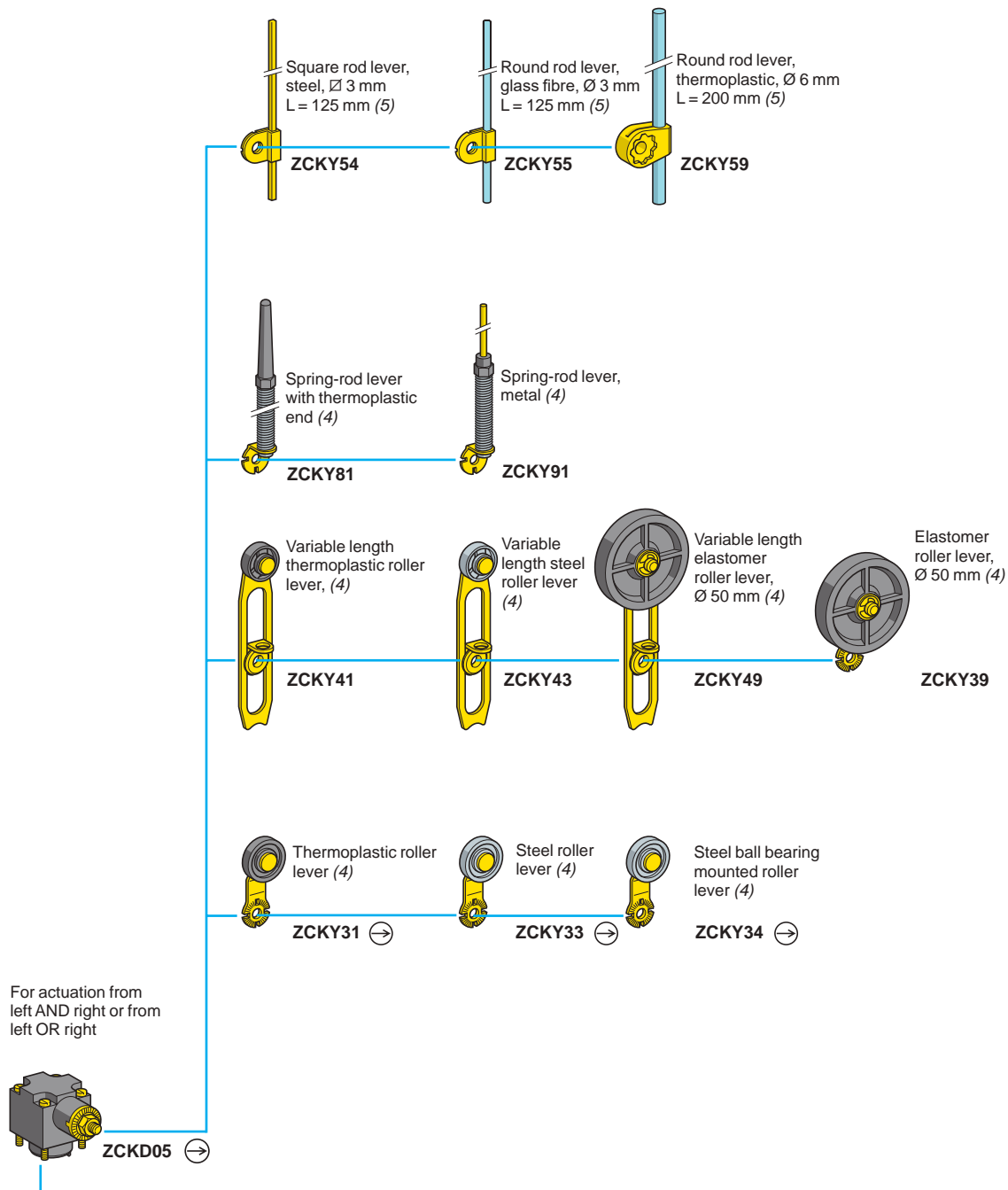

⊖: head assuring positive opening operation.

(4) Adjustable throughout 360° in 5° steps, or in 90° steps by reversing the notched washer.

(5) Adjustable throughout 360° in 5° steps, or in 45° steps by reversing the lever mounting.

Limit switches

XC Standard range, Classic format

Metal, XCKM and XCKL

Adaptable sub-assemblies

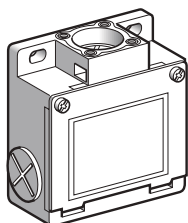

ZCKM●

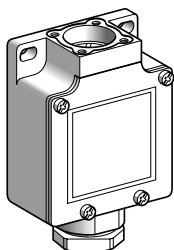

ZCKL●

Bodies with 2-pole contact					
With contact block	Scheme	Positive operation (1)	Cable entry	Reference	Weight kg
For limit switches XCKM					
NC + NO snap action (XE2SP2151)		⊙	Pg 11	ZCKM1	0.210
			ISO M20 x 1.5	ZCKM1H29	0.210
			1/2" NPT (2)	ZCKM1H7	0.210
NC + NO break before make, slow break (XE2NP2151)		⊙	Pg 11	ZCKM5	0.210
			ISO M20 x 1.5	ZCKM5H29	0.210
			1/2" NPT (2)	ZCKM5H7	0.210
NO + NC make before break, slow break (XE2NP2161)		⊙	Pg 11	ZCKM6	0.210
			ISO M20 x 1.5	ZCKM6H29	0.210
NC + NC simultaneous, slow break (XE2NP2141)		⊙	Pg 11	ZCKM7	0.210
			ISO M20 x 1.5	ZCKM7H29	0.210
			1/2" NPT (2)	ZCKM7H7	0.210
NO + NO simultaneous, slow break (XE2NP2131)		-	Pg 11	ZCKM8	0.210
			ISO M20 x 1.5	ZCKM8H29	0.210
NC + NC snap action (XE2SP2141)		⊙	Pg 11	ZCKM9	0.210
			ISO M20 x 1.5	ZCKM9H29	0.210
For limit switches XCKL					
NC + NO snap action (XE2SP2151)		⊙	Pg 13.5	ZCKL1 (3)	0.210
			1/2" NPT	ZCKL1H7	0.210
NC + NO break before make, slow break (XE2NP2151)		⊙	Pg 13.5	ZCKL5 (3)	0.210
			1/2" NPT	ZCKL5H7	0.210
NO + NC make before break, slow break (XE2NP2161)		⊙	Pg 13.5	ZCKL6 (3)	0.210
NC + NC simultaneous, slow break (XE2NP2141)		⊙	Pg 13.5	ZCKL7 (3)	0.210
			1/2" NPT	ZCKL7H7	0.210
NO + NO simultaneous, slow break (XE2NP2131)		-	Pg 13.5	ZCKL8 (3)	0.210
			1/2" NPT	ZCKL8H7	0.210

(1) ⊙: NC contact with positive opening operation.

(2) 3 tapped entries, one with metal adaptor for 1/2" NPT (USASB2-1) conduit.

(3) Pg 13.5 cable gland included with switch.

Limit switches

XC Standard range, Classic format

Metal, XCKM and XCKL

Adaptable sub-assemblies

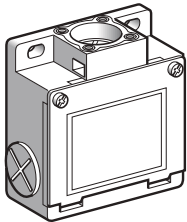

ZCKMD3●

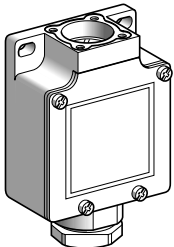

ZCKLD3●

Bodies with 3-pole contact					
With contact block	Scheme	Positive operation (1)	Cable entry	Reference	Weight kg
For limit switches XCKM					
NC + NO + NO snap action (XE3SP2151)		⊖	Pg 11	ZCKMD31	0.210
			ISO M20 x 1.5	ZCKMD31H29	0.210
NC + NC + NO snap action (XE3SP2141)		⊖	Pg 11	ZCKMD39	0.210
			ISO M20 x 1.5	ZCKMD39H29	0.210
			1/2" NPT (2)	ZCKMD39H7	0.210
NC + NC + NO break before make, slow break (XE3NP2141)		⊖	Pg 11	ZCKMD37	0.210
			ISO M20 x 1.5	ZCKMD37H29	0.210
NC + NO + NO break before make, slow break (XE3NP2151)		⊖	Pg 11	ZCKMD35	0.210
			ISO M20 x 1.5	ZCKMD35H29	0.210
For limit switches XCKL					
NC + NO + NO snap action (XE3SP2151)		⊖	Pg 13.5	ZCKLD31 (3)	0.210
			1/2" NPT	ZCKLD31H7	0.210
NC + NC + NO snap action (XE3SP2141)		⊖	Pg 13.5	ZCKLD39 (3)	0.210
NC + NC + NO break before make, slow break (XE3NP2141)		⊖	Pg 13.5	ZCKLD37 (3)	0.210
			1/2" NPT		0.210

(1) ⊖ : NC contact with positive opening operation.

(2) 3 tapped entries, one with metal adaptor for 1/2" NPT (USASB2-1) conduit.

(3) Pg 13.5 cable gland included with switch.

Limit switches

XC Standard range, Classic format
Metal, XCKM and XCKL
Adaptable sub-assemblies

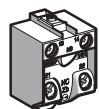

XE2SP21●1

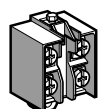

XE2NP21●1

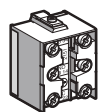

XE3●P21●●

Contact blocks					
Type of contact	Scheme	For bodies	Positive operation (1)	Reference	Weight kg
2-pole contact					
NC + NO snap action		ZCKM1 ZCKL1	⊙	XE2SP2151	0.020
NC + NO break before make, slow break		ZCKM5 ZCKL5	⊙	XE2NP2151	0.020
NO + NC make before break, slow break		ZCKM6 ZCKL6	⊙	XE2NP2161	0.020
NC + NC simultaneous, slow break		ZCKM7 ZCKL7	⊙	XE2NP2141	0.020
NO + NO simultaneous, slow break		ZCKM8 ZCKL8	—	XE2NP2131	0.020
NC + NC snap action		ZCKM9	⊙	XE2SP2141	0.020
3-pole contact					
NC + NO + NO snap action		ZCKMD31 ZCKLD31	⊙	XE3SP2151	0.035
NC + NC + NO snap action		ZCKMD39 ZCKLD39	⊙	XE3SP2141	0.035
NC + NC + NO break before make, slow break		ZCKMD37 ZCKLD37	⊙	XE3NP2141	0.035
NC + NO + NO break before make, slow break		ZCKMD35	⊙	XE3NP2151	0.035

(1) ⊙: NC contact with positive opening operation or sub-assembly assuring positive opening operation.

Other versions

Gold flashed contacts.
Please consult our Customer Care Centre.

Limit switches

XC Standard range, Classic format
Metal, XCKM and XCKL
Adaptable sub-assemblies

Heads ZCKD10, D109 with body

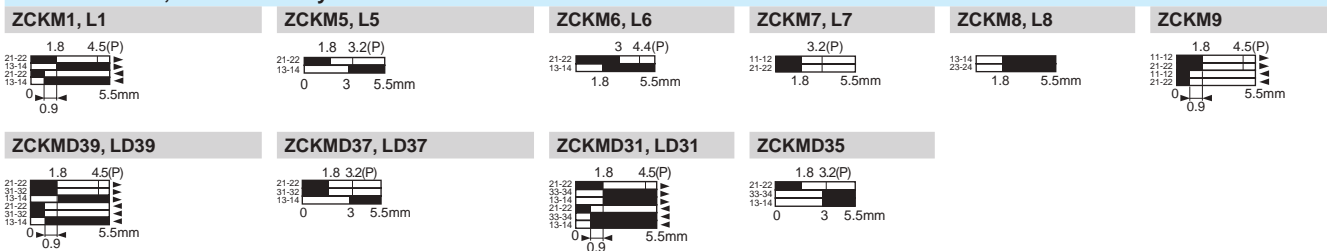

Heads ZCKD02, D029 with body

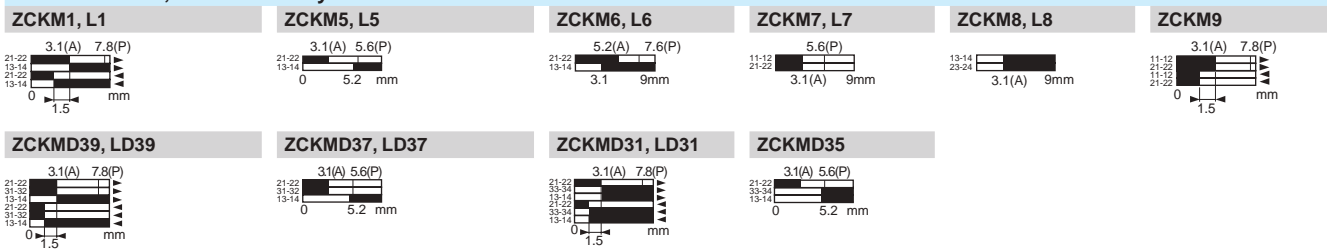

Heads ZCKD21, D23, D219, D239 with body

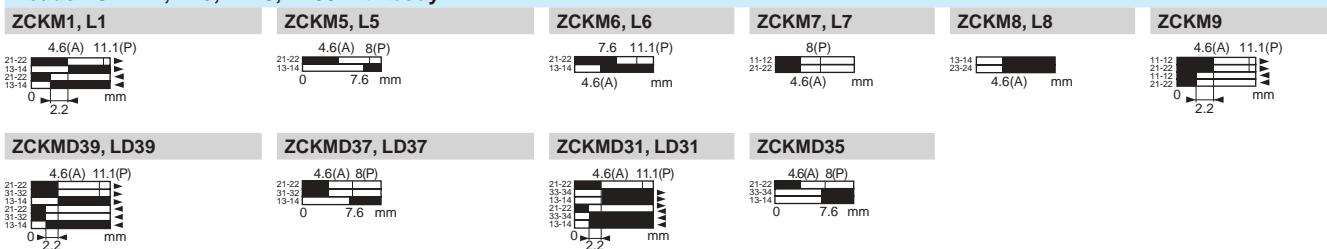

Heads ZCKD15, D16, D17 with body

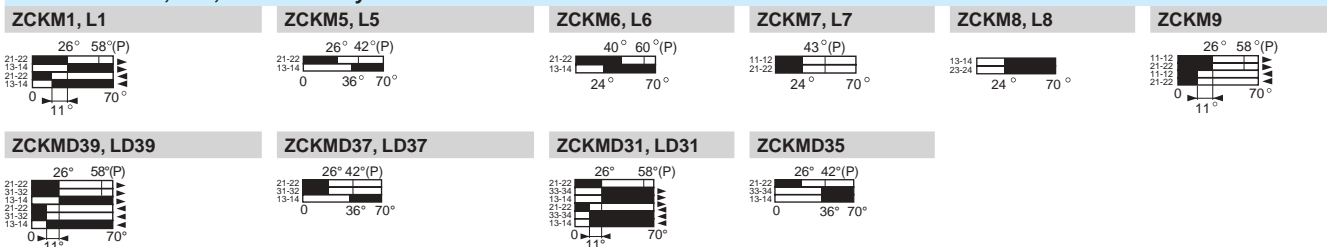

Heads ZCKD41, D59, D81, D91 with body

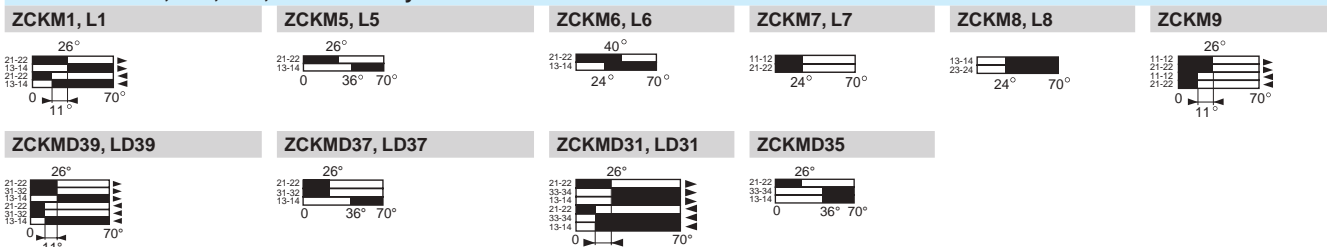

Heads ZCKD06, D08 with body

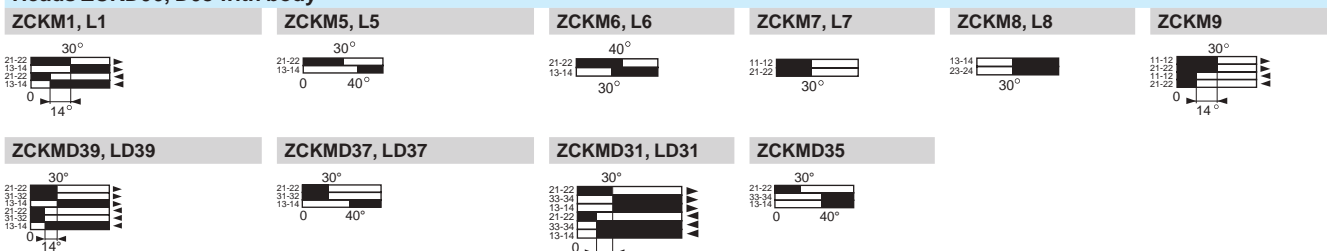

Contact operation closed open (A) = cam displacement (P) = positive opening point

Limit switches

XC Standard range, Classic format
Metal, XCKM and XCKL
Adaptable sub-assemblies

Bodies with contacts

ZCKM1, M5, M6, M7, M8, M9, MD3●, MD3H●29, MD3●H7
ZCKM1H29, M5H29, M6H29, M7H29, M8H29, M9H29
ZCKM1H7, M5H7, M6H7, M7H7, M8H7

ZCKL1, L5, L6, L7, L8, LD3● (with incorporated Pg 13.5 cable gland)
ZCKL1H7, L5H7, L6H7, L7H7, L8H7, LD3●H7 (with 1/2" NPT cable entry)

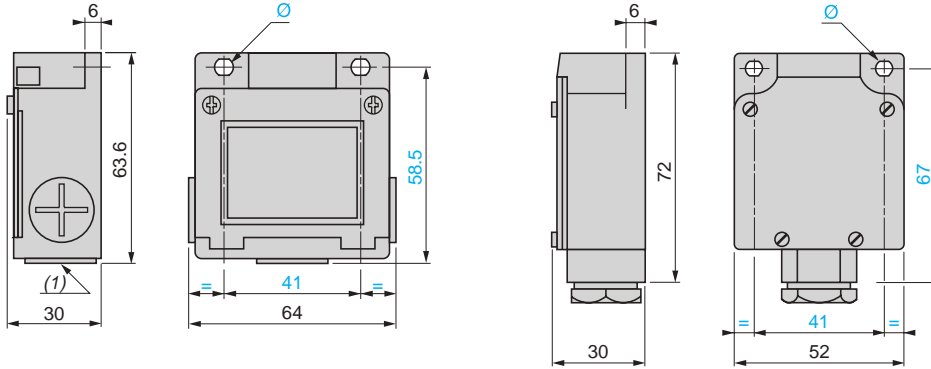

Adaptor for 1/2" NPT conduit

DE9RA1012

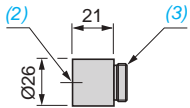

(1) 3 tapped entries for ISO M20 x 1.5 or Pg 11 cable gland.

Ø: 2 elongated holes Ø 5.2 x 6.2

(2) Tapped entry for 1/2" NPT conduit.

(3) Pg 11 threaded sleeve.

Limit switches

XC Standard range, Classic format

Metal, XCKM and XCKL

Adaptable sub-assemblies

Plunger heads

ZCKD10

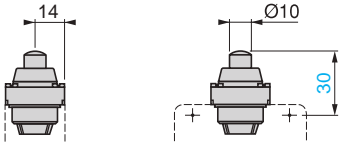

ZCKD109

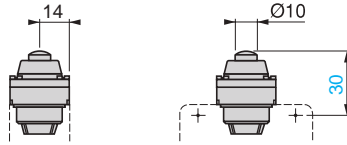

ZCKD02

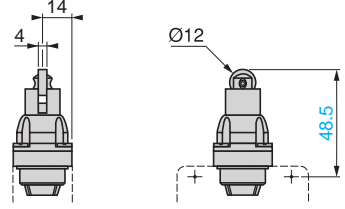

ZCKD029

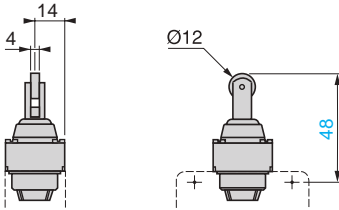

ZCKD21, ZCKD23

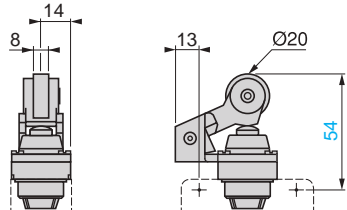

ZCKD219, ZCKD239

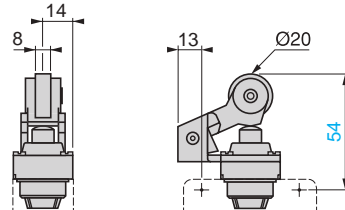

Rotary heads

ZCKD15, ZCKD16, ZCKD17

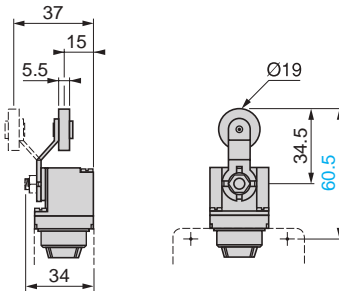

ZCKD41

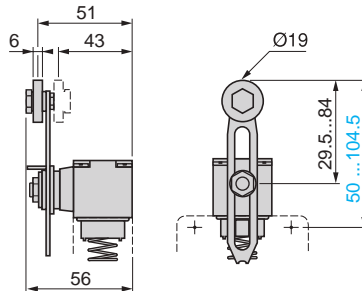

ZCKD59

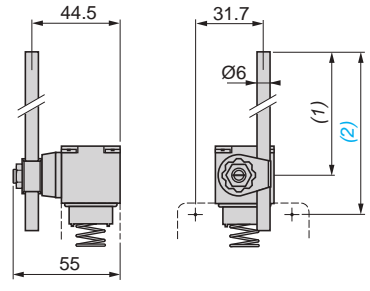

ZCKD81

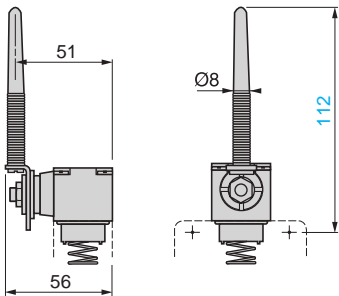

ZCKD91

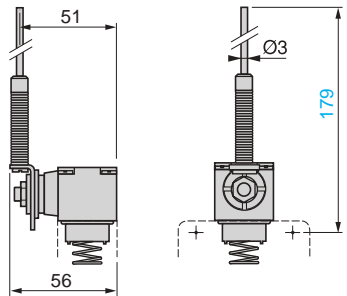

Multi-directional heads

ZCKD06

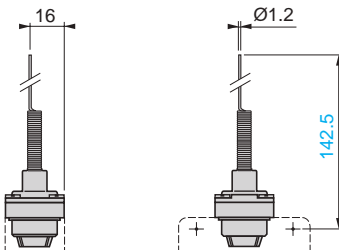

ZCKD08

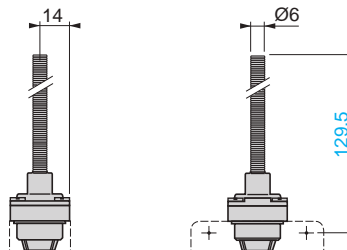

(1) 190 max.
(2) 215.5 max.

Note: operating lever spindle threaded M6.

Limit switches

XC Standard range, format EN 50041
Plastic, double insulated, XCKS

Complete switch

with 2 contacts (NO + NC) and 1 cable entry

■ The XCKS limit switches range, with 2 integrated contacts, offers “all-in-one”, ready to use products.

□ XCKS, with head for linear (plunger) and rotary (lever) movement



Variable composition switch

with 2, 3 or 4 contacts and 1 cable entry

■ The variable composition range expands the offer up to 4 contacts and choice among 18 different actuators.

□ ZCKD: complete head with linear or rotary actuator
□ ZCKS: bodies with 2, 3 or 4 contacts



Environment characteristics

Conformity to standards	Products	CE, EN/IEC 60947-5-1, UL 508, CSA C22-2 n°14, CCC, EAC
	Machine assemblies	EN/IEC 60204-1
Product certifications		UL, CSA, CCC, EAC
Protective treatment	Version	Standard “TC”, special “TH”
Ambient air temperature	For operation	- 25...+ 70 °C
	For storage	- 40...+ 70 °C
Vibration resistance	Conforming to EN/IEC 60068-2-6	25 gn (10...500 Hz)
Shock resistance	Conforming to EN/IEC 60068-2-27	XCKS1●●: 40 gn (11 ms) XCKS5●●: 50 gn (11 ms)
Electric shock protection	Conforming to EN/IEC 61140	Class II
Degree of protection	Conforming to EN/IEC 60529	XCKS1●●, XCKS5●●: IP 66 and IP 67 ZCKS: IP 65
	Conforming to EN 62262	XCKS1●●, XCKS5●●: IK 05 ZCKS: IK 03
Cable entry	Depending on model	Tapped entry for cable gland: ■ Pg 13.5 ■ ISO M20 x 1.5 ■ 1/2" NPT
Materials		Bodies and heads: plastic

Contact block characteristics		
Type of contacts	Conforming to EN/IEC 60947-5-1	Type Zb, electrically separate double break contacts
Positive operation (depending on model)		NC contacts with positive opening operation conforming to EN/IEC 60947-5-1 Appendix K
Rated operational characteristics	XCKS1●●, XCKS5●● XE2●P●, XESP●	~ AC-15 ; A300 (U _e = 240 V, I _e = 3 A) ; I _{the} = 10 A --- DC-13 ; Q300 (U _e = 250 V, I _e = 0.27 A), conforming to EN/IEC 60947-5-1 Appendix A
	XE3●P●	~ AC-15 ; B300 (U _e = 240 V, I _e = 1.5 A) ; I _{the} = 6 A --- DC-13 ; R300 (U _e = 250 V, I _e = 0.1 A), conforming to EN/IEC 60947-5-1 Appendix A
Rated insulation voltage	XCKS1●●, XCKS5●● XE2●P●, XESP●	U _i = 500 V degree of pollution 3 conforming to EN/IEC 60947-5-1
	XE3●P●	U _i = 300 V conforming to UL 508 and CSA C22-2 n° 14
Rated impulse withstand voltage	XCKS1●●, XCKS5●● XE2●P●, XESP●	U _{imp} = 6 kV conforming to EN/IEC 60947-1, IEC 60664
	XE3●P●	U _{imp} = 4 kV conforming to EN/IEC 60947-1, IEC 60664
Short-circuit protection	XCKS1●●, XCKS5●● XE2●P●, XESP●	10 A cartridge fuse type gG (gl)
	XE3●P●	6 A cartridge fuse type gG (gl)
Resistance across terminals		≤ 25 mΩ conforming to EN/IEC 60255-7 category 3
Connection (screw clamp terminals)	XCKS1●●, XCKS5●● XE2SP21●1	Clamping capacity, min: 1 x 0.34 mm ² / AWG 22, max: 2 x 1.5 mm ² / AWG 16
	XE2NP21●1	Clamping capacity, min: 1 x 0.5 mm ² / AWG 20, max: 2 x 2.5 mm ² / AWG 14
	XESP●	Clamping capacity, min: 1 x 0.75 mm ² / AWG 20, max: 2 x 1.5 mm ² / AWG 16
	XE3●P●	Clamping capacity, min: 1 x 0.34 mm ² / AWG 22, max: 1 x 1 mm ² / AWG 18 or 2 x 0.75 mm ² / AWG 20
Minimum actuation speed		Snap action contacts (XCKS1●, XE●SP● and XESP●): 0.01 m/minute Slow break contacts (XCKS5●, XE2NP● and XE3NP●): 6 m/minute
Electrical durability	XCKS1●● + LC1D38 / ~ 230 V	15 million operating cycles
	XCKS5●● + LC1D38 / ~ 230 V	20 million operating cycles
	ZCKS	<ul style="list-style-type: none"> ■ Conforming to IEC 60947-5-1 Appendix C ■ Utilisation categories AC-15 and DC-13 ■ Maximum operating rate: 3600 operating cycles/hour ■ Load factor: 0.5

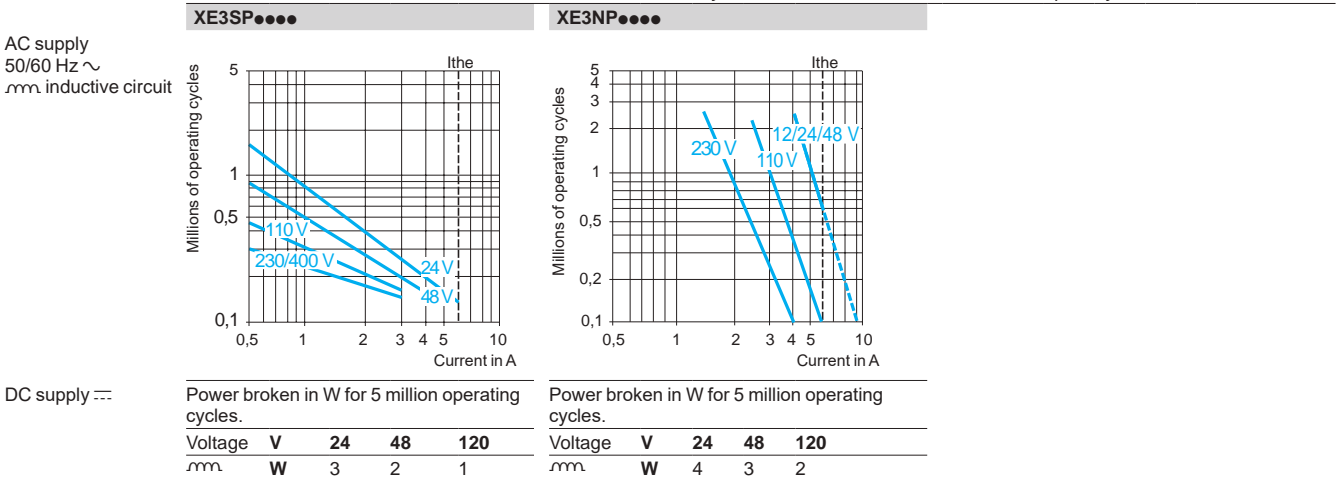
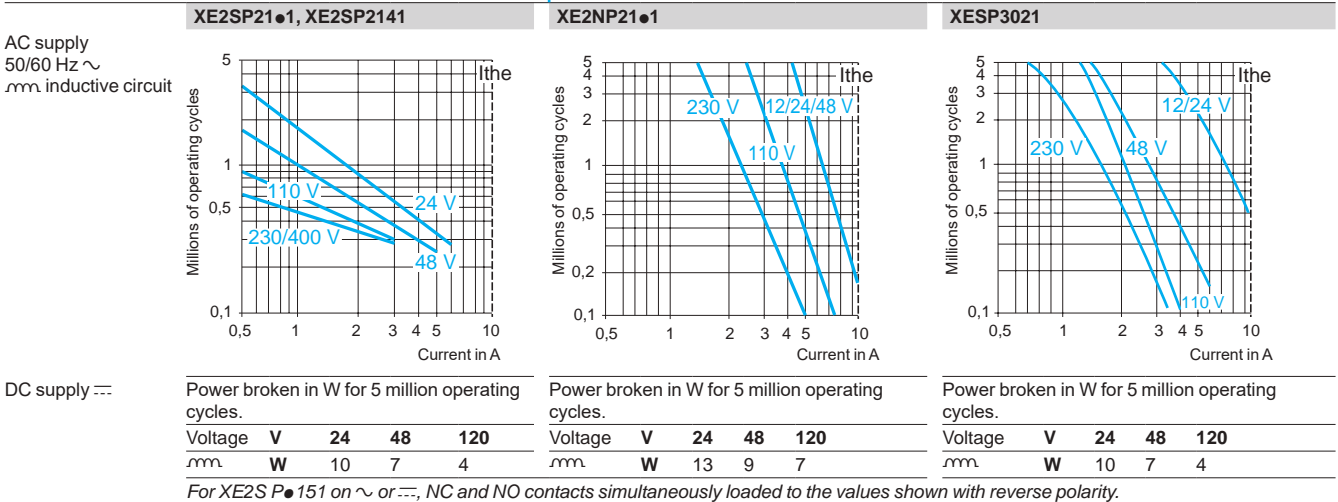

Limit switches

XC Standard range, format EN 50041

Plastic, double insulated, XCKS

Complete switches with 1 cable entry

Type of head	Plunger (fixing by the body)	Rotary (fixing by the body)
--------------	------------------------------	-----------------------------



Form conforming to EN 50041 (1)	B	C	A	A	A	A	D
Type of operator	Metal end plunger	Steel roller plunger	Thermoplastic or steel roller lever (2)	Elastomer roller lever, Ø 50 mm (2)	Variable length thermoplastic or steel roller lever (2)	Variable length elastomer roller lever, Ø 50 mm (2)	Round thermoplastic rod lever, Ø 6 mm (3) (4)
Positive operation	⊕	⊖	⊕	–	⊕	–	–

References of complete switches with 1 ISO M20 x 1.5 cable entry

<p>2-pole NC + NO snap action</p>	XCKS101H29	XCKS102H29	XCKS131H29 (thermoplastic) XCKS133H29 (steel)	XCKS139H29	XCKS141H29 (thermoplastic) XCKS143H29 (steel)	XCKS149H29	XCKS159H29
<p>2-pole NC + NO break before make, slow break</p>	XCKS501H29	XCKS502H29	XCKS531H29 (thermoplastic)	XCKS539H29	XCKS541H29 (thermoplastic) XCKS543H29 (steel)		XCKS559H29
Weight (kg)	0.125	0.135	0.160	0.175	0.165	0.180	0.170
Contact operation			(A) = cam displacement (P) = positive opening point		⊕ NC contact with positive opening operation		

References of complete switches with 1 Pg 13.5 cable entry

For an entry tapped for a Pg 13.5 cable gland, delete H29 from the end of the reference. (Except XCKS133H29, XCKS143H29 and XCKS543H29). Example: XCKS101H29 becomes XCKS101.

References of complete switches with 1/2" NPT cable entry

For an entry tapped for a 1/2" NPT cable gland, replace H29 at the end of the reference by H7. (Except XCKS133H29, XCKS143H29, XCKS501H29, XCKS539H29, XCKS543H29, and XCKS559H29). Example: XCKS101H29 becomes XCKS101H7.

Characteristics

Switch actuation	On end	By 30° cam		By any moving part		
Type of actuation						
Maximum actuation speed	0.5 m/s		1.5 m/s	1 m/s		
Mechanical durability (in millions of operating cycles)	25	15	20			
Minimum force or torque	For tripping	15 N	12 N	0.10 N.m		
	For positive opening	30 N	20 N	0.15 N.m	–	0.15 N.m
Cable entry	1 entry tapped M20 x 1.5 mm for ISO cable gland, clamping capacity 7 to 13 mm					

(1) Form conforming to EN 50041, see page 25.

(2) Adjustable throughout 360° in 5° steps, or in 90° steps by reversing the notched washer.

(3) Adjustable throughout 360° in 5° steps, or in 45° steps by reversing the lever mounting.

(4) Value taken with actuation by moving part at 100 mm from the fixing.

Limit switches

XC Standard range, format EN 50041
Plastic, double insulated, XCKS
Variable composition switches with 1 cable entry



Note: ZCKD heads can only be used with ZCKS bodies.

References of variable composition switches (ZCKS bodies and ZCKD heads) with 1 ISO M20 x 1.5 cable entry (3)							
Form conforming to EN 50041 (1)	B	C	A	A	A	A	D
Type of operator	Metal end plunger	Steel roller plunger	Thermoplastic roller lever (2)	Elastomer roller lever, Ø 50 mm (2)	Variable length thermoplastic roller lever (2)	Variable length elastomer roller lever, Ø 50 mm (2)	Round thermoplastic rod lever, Ø 6 mm (4) (5)
Positive operation	⊕	⊕	⊕	—	⊕	—	—
<p>2-pole NC + NC snap action (XE2SP2141)</p>	<p>ZCKS9H29 + ZCKD01</p>	<p>ZCKS9H29 + ZCKD02</p>	<p>ZCKS9H29 + ZCKD31</p>	<p>ZCKS9H29 + ZCKD39</p>	<p>ZCKS9H29 + ZCKD41</p>	<p>ZCKS9H29 + ZCKD49</p>	<p>ZCKS9H29 + ZCKD59</p>
<p>2-pole NC + NC simultaneous, slow break (XE2NP2141)</p>	<p>ZCKS7H29 + ZCKD01</p>	<p>ZCKS7H29 + ZCKD02</p>	<p>ZCKS7H29 + ZCKD31</p>	<p>ZCKS7H29 + ZCKD39</p>	<p>ZCKS7H29 + ZCKD41</p>	<p>ZCKS7H29 + ZCKD49</p>	<p>ZCKS7H29 + ZCKD59</p>
<p>3-pole NC + NC + NO snap action (XE3SP2141)</p>	<p>ZCKSD39H29 + ZCKD01</p>	<p>ZCKSD39H29 + ZCKD02</p>	<p>ZCKSD39H29 + ZCKD31</p>	<p>ZCKSD39H29 + ZCKD39</p>	<p>ZCKSD39H29 + ZCKD41</p>	<p>ZCKSD39H29 + ZCKD49</p>	<p>ZCKSD39H29 + ZCKD59</p>
Weight (kg)	0.095	0.105	0.145	0.150	0.155	0.155	0.150
Contact operation			(A) = cam displacement (P) = positive opening point		⊕ NC contact with positive opening operation		

References of variable composition switches (ZCKS bodies and ZCKD heads) with 1 Pg 13.5 cable entry

For ZCKS bodies with 1 Pg 13.5 cable entry, delete H29 from the end of the reference. Example: ZCKS1H29 becomes ZCKS1.

Characteristics							
Switch actuation	On end	By 30° cam		By any moving part			
Type of actuation							
Maximum actuation speed	0.5 m/s		1.5 m/s			1 m/s	
Mechanical durability (6) (in millions of operating cycles)	25	15	20	or			
Minimum force or torque	For tripping	15 N	12 N	0.15 N.m			
	For positive opening	45 N	36 N	0.3 N.m	—	0.3 N.m	—
Cable entry	1 entry tapped M20 x 1.5 mm for ISO cable gland, clamping capacity 7 to 13 mm						

(1) Form conforming to EN 50041, see page 25.
 (2) Adjustable throughout 360° in 5° steps, or in 90° steps by reversing the notched washer.
 (3) Switches with gold contacts or eyelet type connections: please consult our Customer Care Centre.
 (4) Adjustable throughout 360° in 5° steps, or in 45° steps by reversing the lever mounting.
 (5) Value taken with actuation by moving part at 100 mm from the fixing.
 (6) Limited to 15 million operating cycles for switches with contacts XE3●P.

Limit switches

XC Standard range, format EN 50041

Plastic, double insulated, XCKS

Complete switches with 1 cable entry

Dimensions

XCKS0100

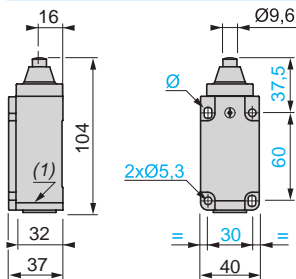

XCKS0200

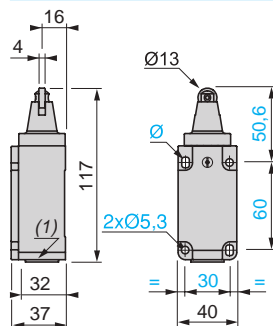

XCKS3100 / XCKS3300

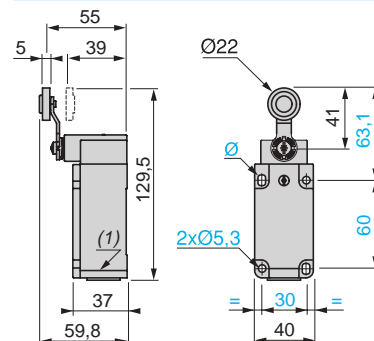

XCKS3900

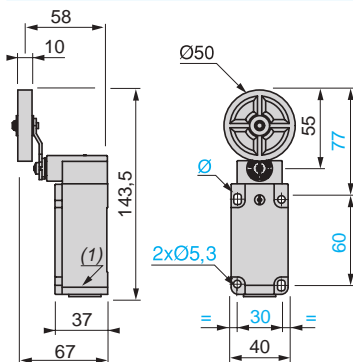

XCKS4100 / XCKS4300

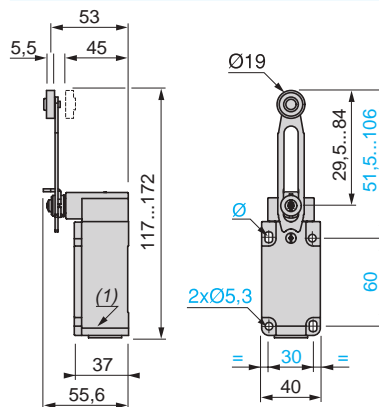

XCKS4900

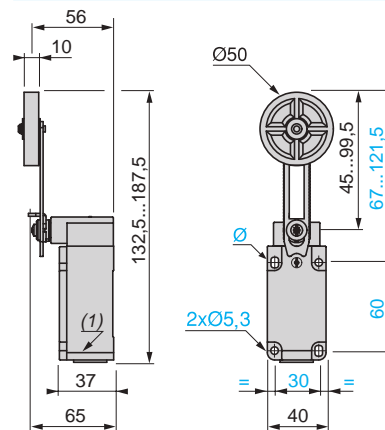

XCKS5900

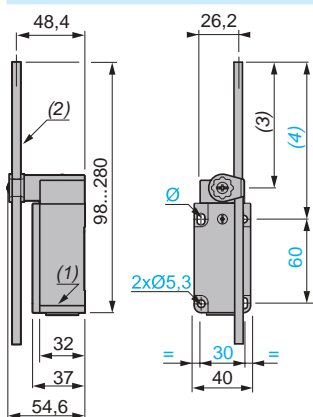

(1) 1 tapped entry for ISO M20 x 1.5 or Pg 13.5 or 1/2" NPT cable gland.

(2) Ø 6 rode, lenght 200 mm.

(3) 190 max.

(4) 212 max.

Ø : 2 elongated holes 5.3 x 7.3 mm.

Limit switches

XC Standard range, format EN 50041

Plastic, double insulated, XCKS

Variable composition switches with 1 cable entry

Dimensions

ZCKS● + ZCKD01

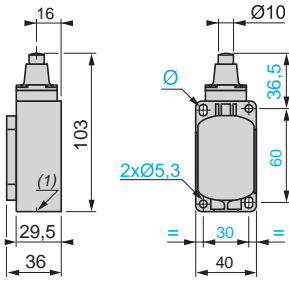

ZCKS● + ZCKD02

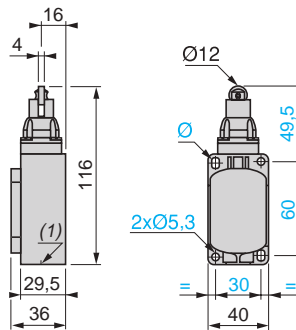

ZCKS● + ZCKD31

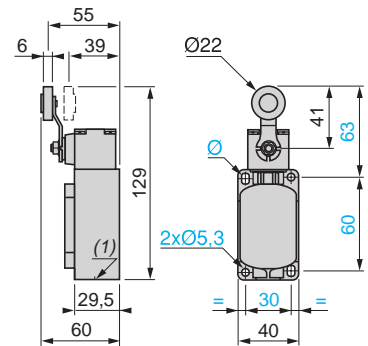

ZCKS● + ZCKD39

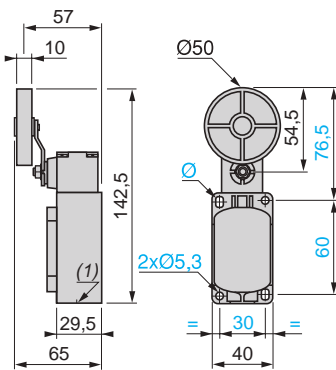

ZCKS● + ZCKD41

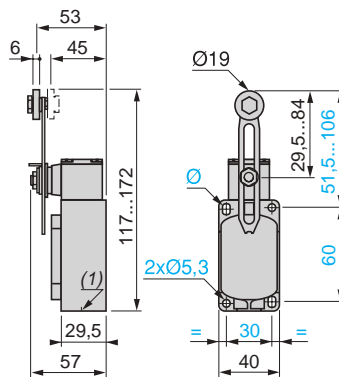

ZCKS● + ZCKD49

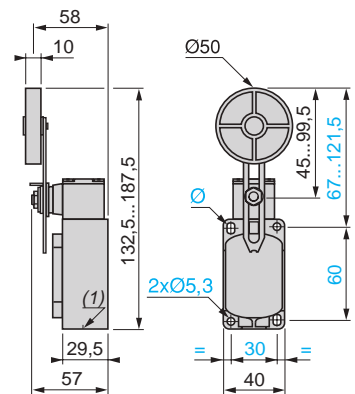

ZCKS● + ZCKD59

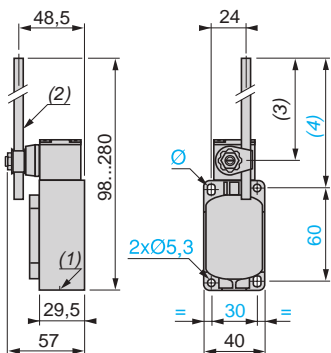

(1) 1 tapped entry for ISO M20 x 1.5 or Pg 13.5 or 1/2" NPT cable gland.

(2) Ø 6 rode, lenght 200 mm.

(3) 190 max.

(4) 212 max.

Ø : 2 elongated holes 5.3 x 7.3 mm.

Limit switches

XC Standard range, format EN 50041

Plastic, double insulated, XCKS

Variable composition

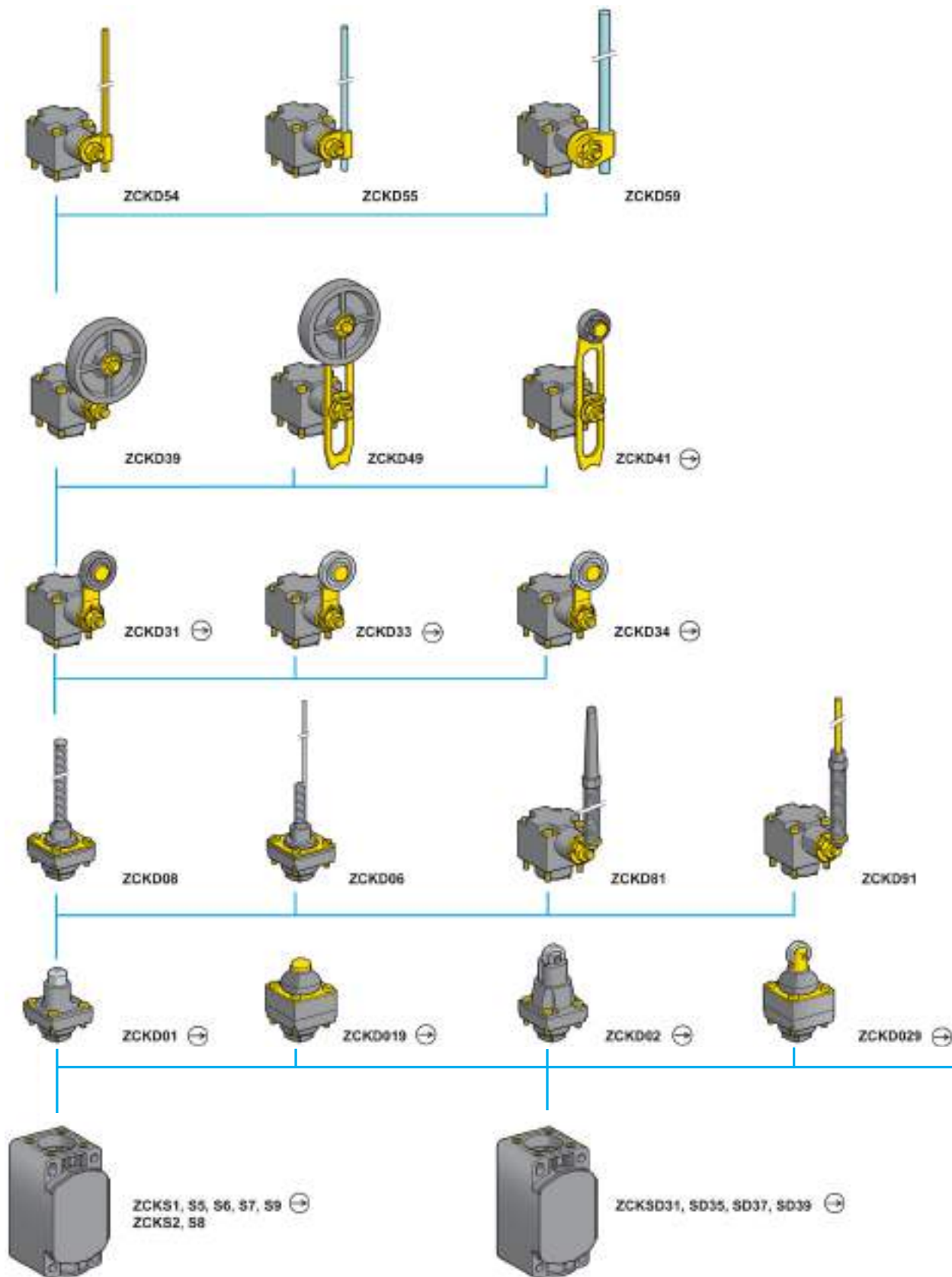

(1) For further details see page 141. For a cable entry tapped ISO M20 x 1.5, add **H29** to the reference.
 Example: ZCKS1 becomes **ZCKS1H29**.

(2) Adjustable throughout 360° in 5° steps, or in 90° steps by reversing the notched washer.

(3) Adjustable throughout 360° in 5° steps, or in 45° steps by reversing the lever mounting.

Note: ZCKD heads can only be used with ZCKS bodies.

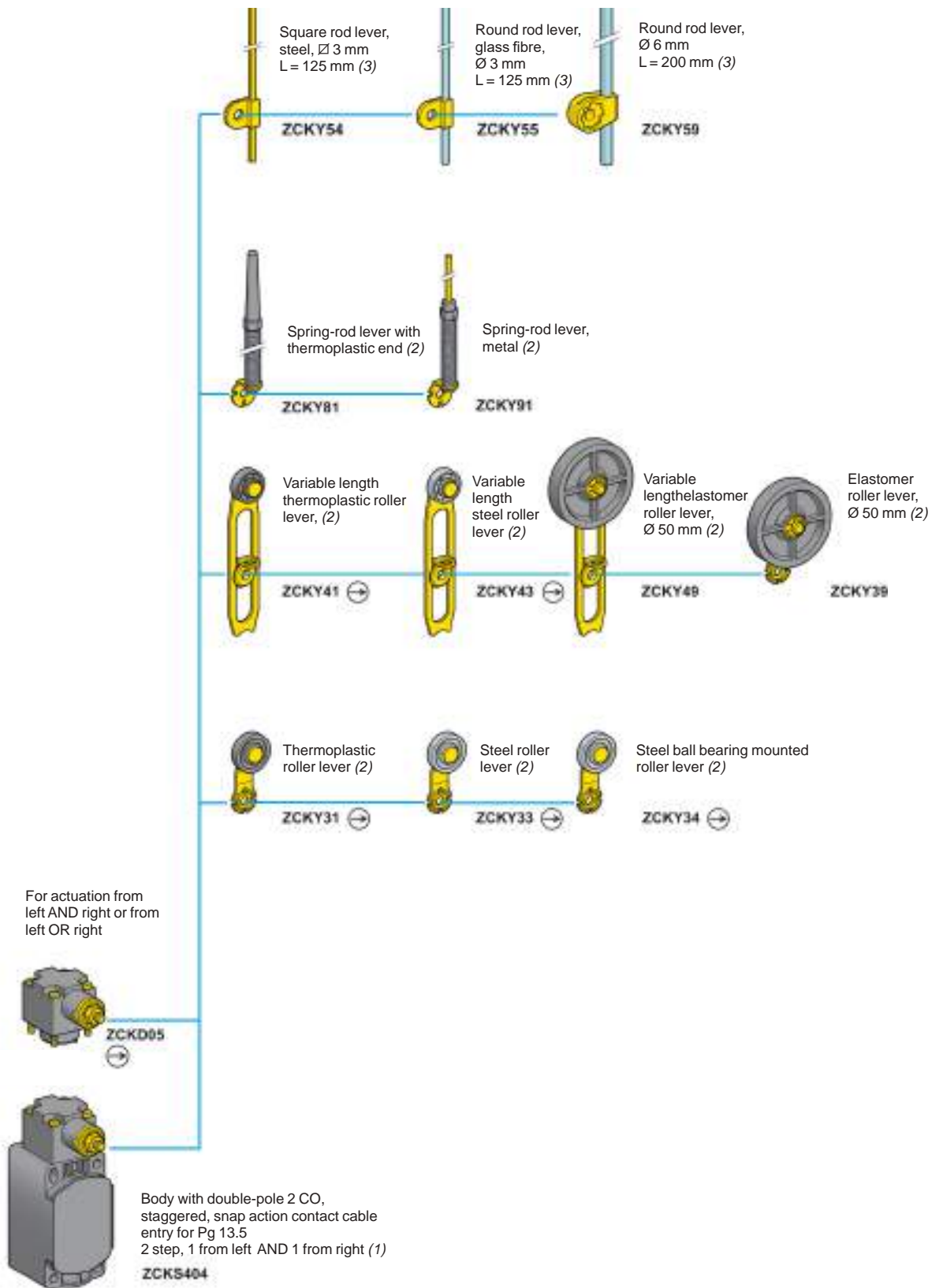

Limit switches

XC Standard range, format EN 50041

Plastic, double insulated, XCKs

Variable composition switches

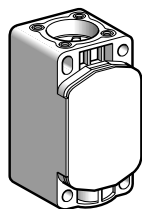

ZCKs

Bodies with 2-pole contact

Type	With contact block	Scheme	Positive operation (1)	Cable entry	Reference	Weight kg
1 step	NC + NO snap action (XE2SP2151)		⊕	Pg 13.5	ZCKS1	0.080
				ISO M20 x 1.5	ZCKS1H29	0.080
	2 CO simultaneous, snap action (XESP3021)		-	Pg 13.5	ZCKS2	0.080
				ISO M20 x 1.5	ZCKS2H29	0.080
	NC + NO break before make, slow break (XE2NP2151)		⊕	Pg 13.5	ZCKS5	0.080
				ISO M20 x 1.5	ZCKS5H29	0.080
	NO + NC make before break, slow break (XE2NP2161)		⊕	Pg 13.5	ZCKS6	0.080
				ISO M20 x 1.5	ZCKS6H29	0.080
NC + NC simultaneous, slow break (XE2NP2141)		⊕	Pg 13.5	ZCKS7	0.080	
			ISO M20 x 1.5	ZCKS7H29	0.080	
NO + NO simultaneous, slow break (XE2NP2131)		-	Pg 13.5	ZCKS8	0.080	
			ISO M20 x 1.5	ZCKS8H29	0.080	
NC + NC snap action (XE2SP2141)		⊕	Pg 13.5	ZCKS9	0.080	
			ISO M20 x 1.5	ZCKS9H29	0.080	

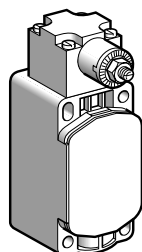

ZCKs404

Bodies with double-pole contact and spring return rotary head

Without operating lever

Type	With contact block	Scheme	Positive operation (1)	Cable entry	Reference	Weight kg
2 step 1 from left and 1 from right	2 CO staggered snap action		-	Pg 13.5	ZCKS404	0.150
				ISO M20 x 1.5	ZCKS404H29	0.150

Bodies with 3-pole contact and 1 cable entry

Type	With contact block	Scheme	Positive operation (1)	Cable entry	Reference	Weight kg
-	NC + NO + NO snap action (XE3SP2151)		⊕	Pg 13.5	ZCKSD31	0.080
				ISO M20 x 1.5	ZCKSD31H29	0.080
-	NC + NC + NO snap action (XE3SP2141)		⊕	Pg 13.5	ZCKSD39	0.080
				ISO M20 x 1.5	ZCKSD39H29	0.080

(1) ⊕: NC contact with positive opening operation or head assuring positive opening operation.

Limit switches

XC Standard range, format EN 50041

Plastic, double insulated, XCKS

Variable composition switches



XE2SP21•1

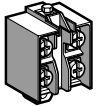

XE2NP21•1

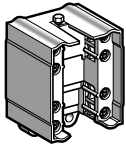

XESP3021

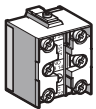

XE3•P21••



DE9RA••12

Contact blocks for ZCKS•• bodies

Type of contact	Scheme	For body	Positive operation (1)	Reference	Weight kg
2-pole contact					
NC + NO snap action		ZCKS1	⊖	XE2SP2151	0.020
NC + NO break before make, slow break		ZCKS5	⊖	XE2NP2151	0.020
2 CO simultaneous snap action		ZCKS2	-	XESP3021	0.045
NO + NC make before break, slow break		ZCKS6	⊖	XE2NP2161	0.020
NC + NC simultaneous, slow break		ZCKS7	⊖	XE2NP2141	0.020
NO + NO simultaneous, slow break		ZCKS8	-	XE2NP2131	0.020
NC + NC snap action		ZCKS9	⊖	XE2SP2141	0.020
3-pole contact					
NC + NO + NO snap action		ZCKSD31	⊖	XE3SP2151	0.035
NC + NC + NO snap action		ZCKSD39	⊖	XE3SP2141	0.035

Accessories for ZCKS•• and XCKS••

Description	Minimum order quantity	Reference	Weight kg
Adaptor for 1/2" NPT conduit (male Pg 13.5 / female 1/2" NPT)	10	DE9RA1212	0.035
Adaptor for 1/2" NPT conduit (male M20 x 1.5 / female 1/2" NPT)	5	DE9RA2012	0.050

(1) ⊖ : NC contact with positive opening operation or sub-assembly assuring positive opening operation.

Other versions

Gold flashed contacts.

Please consult our Customer Care Centre.

Limit switches

XC Standard range, format EN 50041

Plastic, double insulated, XCKS

Variable composition switches

Heads ZCKD01, D109 with body

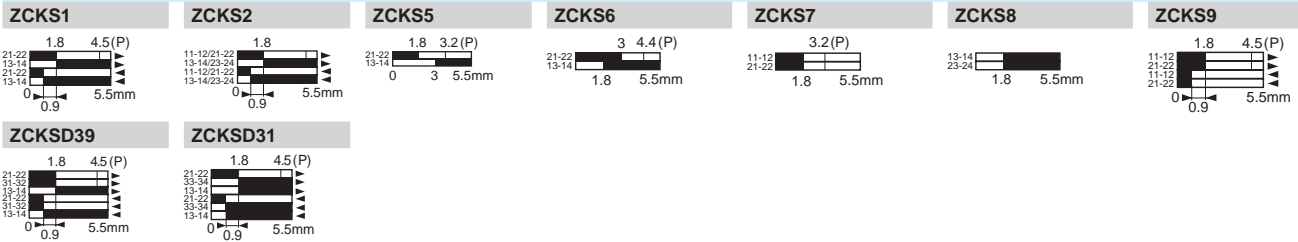

Heads ZCKD02, D029 with body

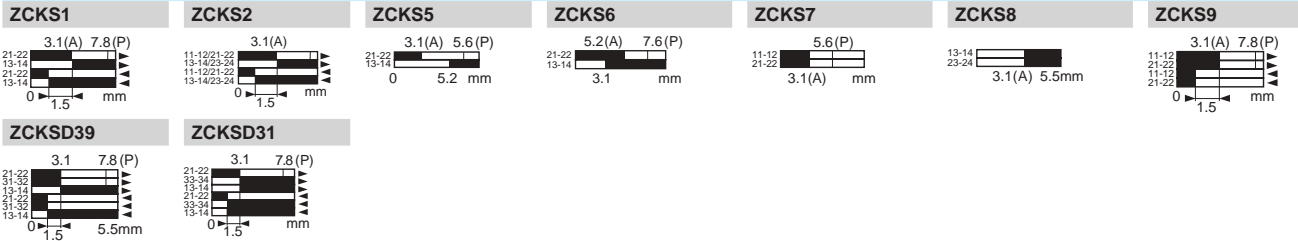

Heads ZCKD31, D33, D34 with body

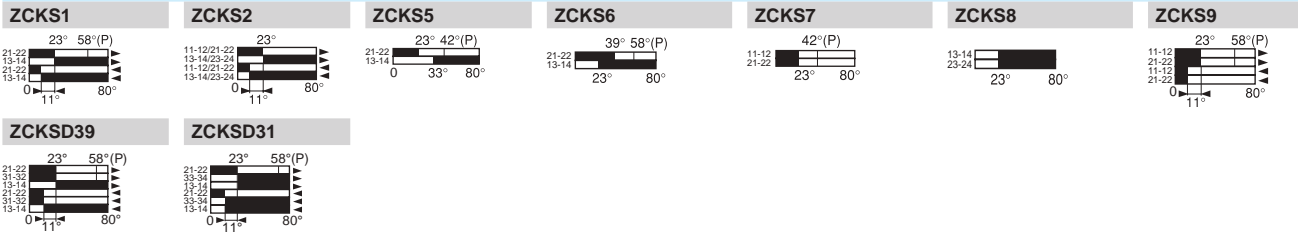

Heads ZCKD39, D41, D49, D54, D55, D59, D81, D91 with body

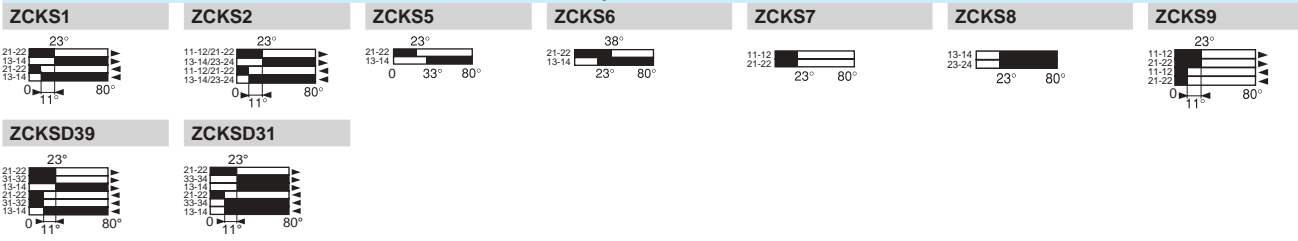

Heads ZCKD05 (positive operation only assured with a ⊖ operating lever) with body

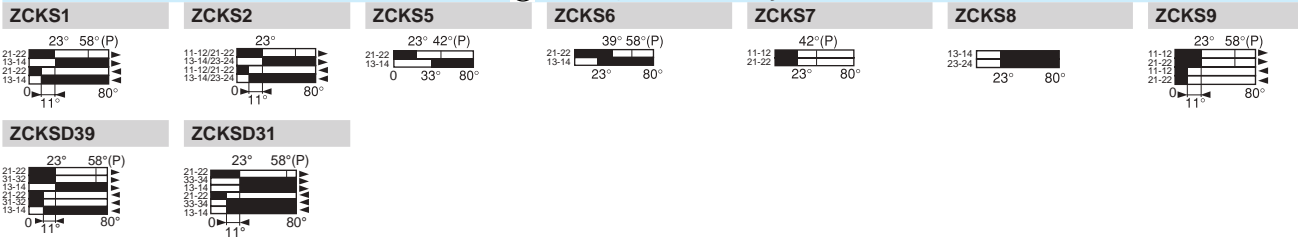

Heads ZCKD06, D08 with body

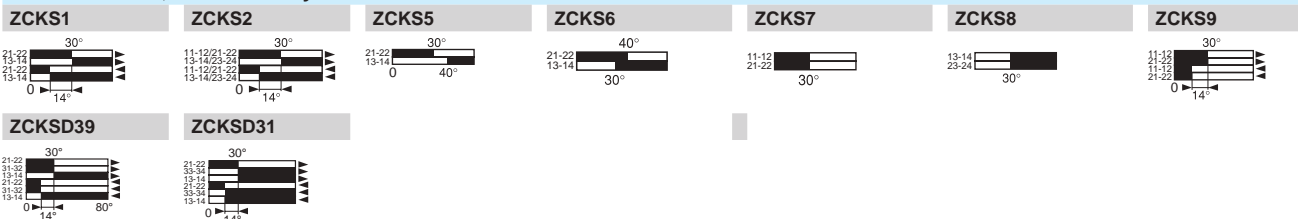

ZCKS404 (body with head)

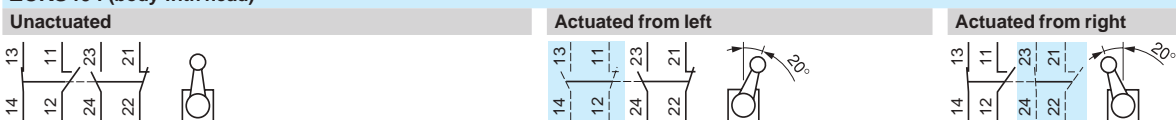

Contact operation

■ closed

□ open

(A) = cam displacement

(P) = positive opening point

Limit switches

XC Standard range, format EN 50041

Plastic, double insulated, XCKs

Variable composition switches

Plunger heads

ZCKD01

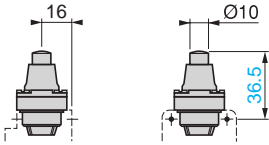

ZCKD019

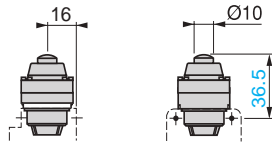

ZCKD02

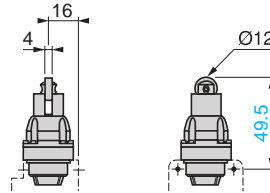

ZCKD029

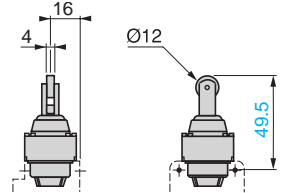

Rotary heads

ZCKD31, ZCKD33, ZCKD34

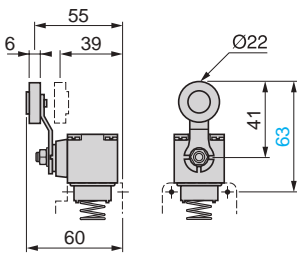

ZCKD39

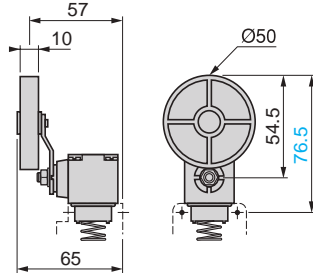

ZCKD41

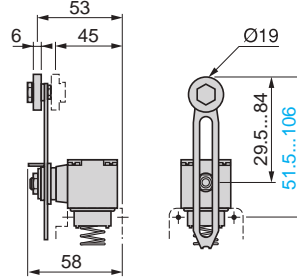

ZCKD49

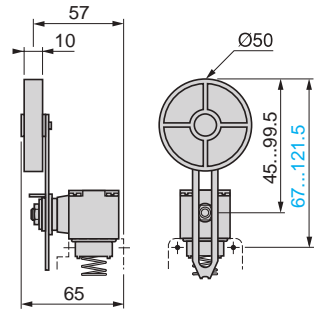

ZCKD54, ZCKD55, ZCKD59

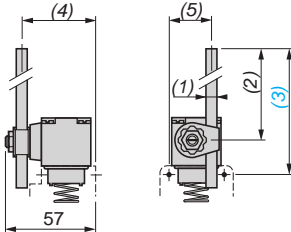

ZCKD81

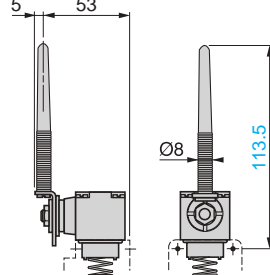

ZCKD91

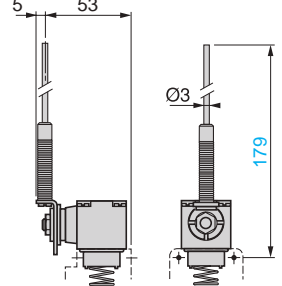

ZCK	(1) rod	(2)	(3)	(4)	(5)
D54	∅ 3, L = 125	115 max.	137 max.	49	24
D55	∅ 3, L = 125	115 max.	137 max.	49	24
D59	∅ 6, L = 200	190 max.	212 max.	46.5	26.2

Note: operating lever spindle threaded M6.

Multi-directional heads

ZCKD06

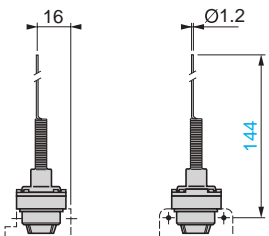

ZCKD08

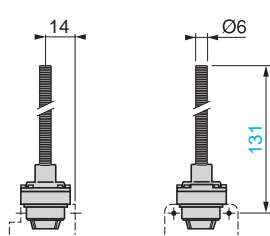

Bodies with contacts

ZCKS1, S2, S5, S6, S7, S8, S9
ZCKS1H29, S2H29, S5H29,
S6H29, S7H29, S8H29, S9H29
ZCKSD3●, SD3●H29

ZCKS404, S404H29

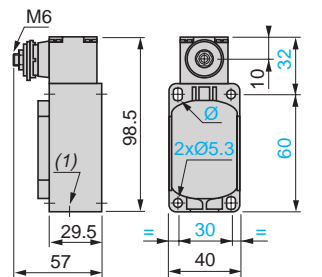
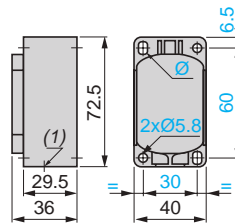

(1) 1 tapped entry for ISO M20 x 1.5 or Pg 13.5 cable gland.
∅: 2 elongated holes 5.3 x 7.3.

Adaptors for 1/2" NPT conduit

DE9RA1212 (Pg 13.5)

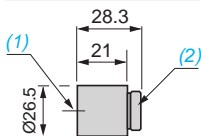

DE9RA2012 (M20)

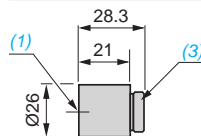

(1) Tapped entry for 1/2" NPT conduit.
(2) Pg 13.5 threaded sleeve.
(3) M20 x 1.5 threaded sleeve.

Limit switches

XC Standard range
Industrial format EN 50041
Metal, XCKJ
Conforming to CENELEC EN 50041

■ XCKJ
fixed body with 1 cable entry

□ With head for linear movement (plunger)

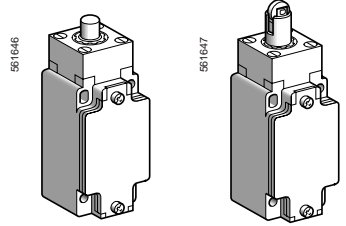

Page 144

□ With head for rotary movement (lever)

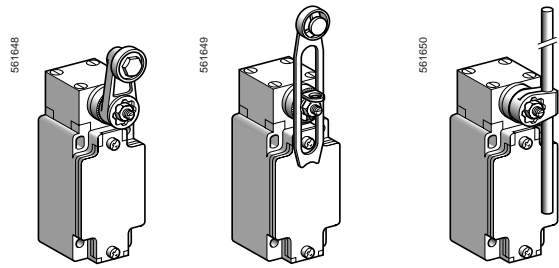

Page 144

■ XCKJ
plug-in body with 1 cable entry

□ With head for linear movement (plunger)

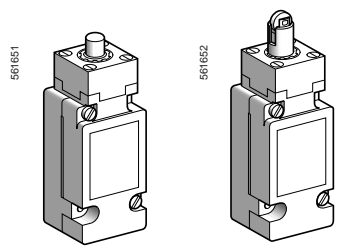

Page 146

□ With head for rotary movement (lever)

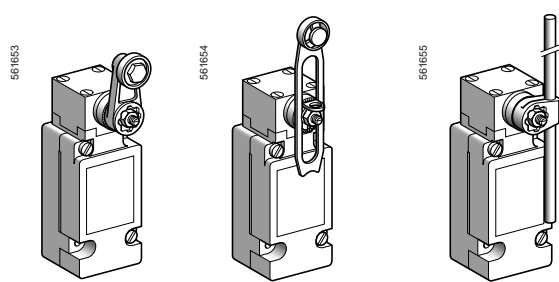

Page 146

Environment characteristics

Conformity to standards	Products	CE, IEC 60947-5-1, EN 60947-5-1, UL 508, CSA C22-2 n° 14, EAC
	Machine assemblies	IEC 60204-1, EN 60204-1
Product certifications		UL, CSA, CCC, BV
Protective treatment	Version	Standard: "TC", special: "TH"
Ambient air temperature	For operation	- 25...+ 70°C, special sub-assemblies for use at - 40°C or + 120°C
	For storage	- 40...+ 70°C
Vibration resistance	Conforming to IEC 60068-2-6	25 gn (10...500 Hz)
Shock resistance	Conforming to IEC 60068-2-27	50 gn (11 ms)
Electric shock protection		Class I conforming to IEC 61140 and NF C 20-030
Degree of protection		IP 66 conforming to IEC 60529; IK 07 conforming to IEC 62262
Repeat accuracy		0.01 mm on the tripping points, with 1 million operating cycles for head with end plunger
Cable entry or connector	Depending on model	Tapped entry for Pg 13.5 cable gland, tapped ISO M20 x 1.5 or tapped 1/2" NPT, or M12 connector
Materials		Bodies and heads in Zamak

Contact block characteristics		
Rated operational characteristics	XE2●P	~ AC-15; A300 (Ue = 240 V, Ie = 3 A); Ithe = 10 A --- DC-13; Q300 (Ue = 250 V, Ie = 0.27 A), conforming to IEC 60947-5-1 Appendix A, EN 60947-5-1
	XE3●P	~ AC-15; B300 (Ue = 240 V, Ie = 1.5 A); Ithe = 6 A --- DC-13; R300 (Ue = 250 V, Ie = 0.1 A), conforming to IEC 60947-5-1 Appendix A, EN 60947-5-1
Rated insulation voltage	XE2●P	Ui = 500 V degree of pollution 3 conforming to IEC 60947-1 Ui = 300 V conforming to UL 508, CSA C22-2 n° 14
	XE3●P	Ui = 400 V degree of pollution 3 conforming to IEC 60947-1 Ui = 300 V conforming to UL 508, CSA C22-2 n° 14
Rated impulse withstand voltage	XE2●P	U imp = 6 kV conforming to IEC 60947-1, IEC 60664
	XE3●P	U imp = 4 kV conforming to IEC 60947-1, IEC 60664
Positive operation (depending on model)		NC contacts with positive opening operation conforming to IEC 60947-5-1 Appendix K, EN 60947-5-1
Resistance across terminals		≤ 25 mΩ conforming to IEC 60255-7 category 3
Short-circuit protection	XE2●P	10 A cartridge fuse type gG (gl)
	XE3●P	6 A cartridge fuse type gG (gl)
Connection (screw clamp terminals)	XE2SP21●1	Clamping capacity, min: 1 x 0.34 mm ² , max: 2 x 1.5 mm ²
	XE2NP21●1	Clamping capacity, min: 1 x 0.5 mm ² , max: 2 x 2.5 mm ²
	XCKJ plug-in and XESP20●1	Clamping capacity, min: 1 x 0.75 mm ² , max: 2 x 1.5 mm ²
	XE3NP and XE3SP	Clamping capacity, min: 1 x 0.34 mm ² , max: 1 x 1 mm ² or 2 x 0.75 mm ²
Minimum actuation speed		XE2SP21●1 and XE3SP : 0.01 m/minute XE2NP21●1 and XE3NP : 6 m/minute

Electrical durability

- Conforming to IEC 60947-5-1 Appendix C
- Utilisation categories AC-15 and DC-13
- Maximum operating rate: 3600 operating cycles/hour
- Load factor: 0.5

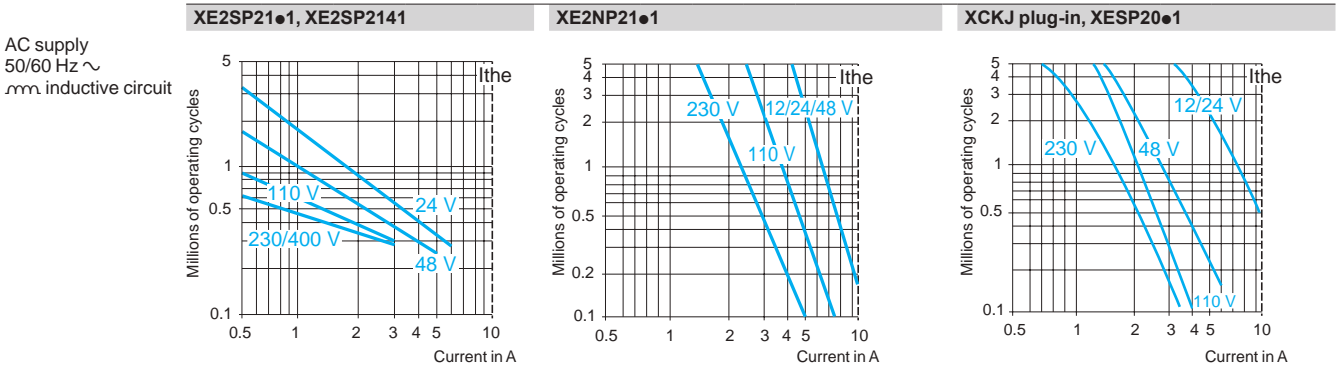

DC supply ---	Power broken in W for 5 million operating cycles.				Power broken in W for 5 million operating cycles.				Power broken in W for 5 million operating cycles.					
Voltage	V	24	48	120	Voltage	V	24	48	120	Voltage	V	24	48	120
mm	W	10	7	4	mm	W	13	9	7	mm	W	10	7	4

For XE2SP●151 on ~ or ---, NC and NO contacts simultaneously loaded to the values shown with reverse polarity.

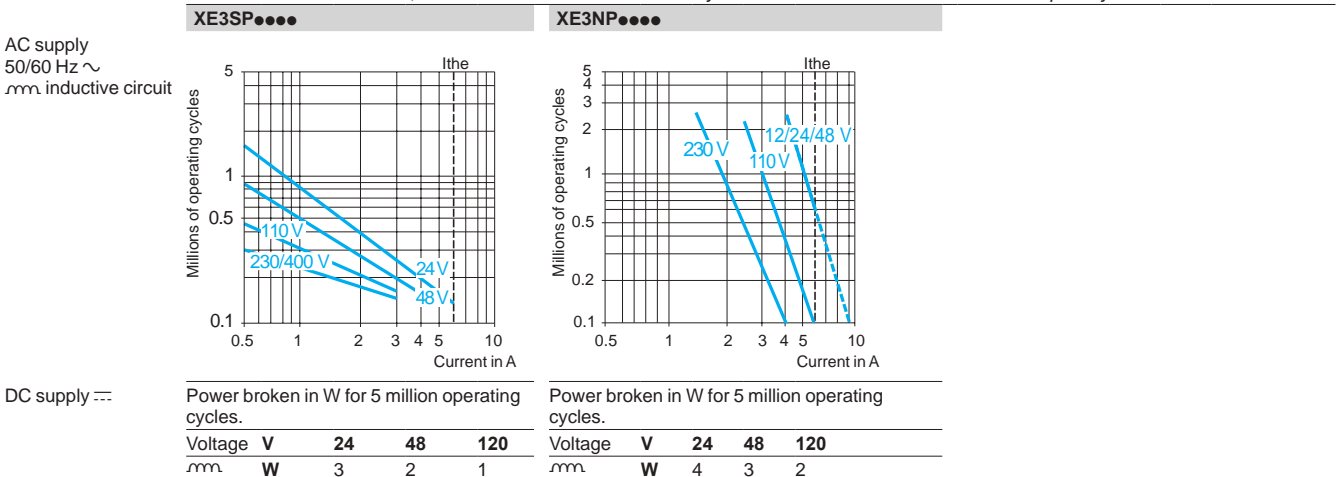











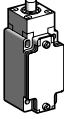



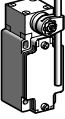

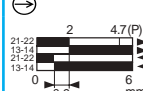
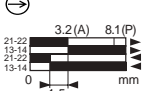
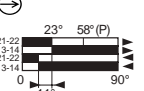
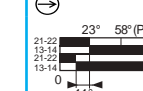



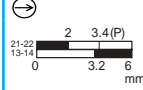
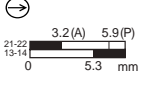
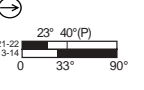
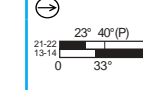



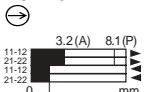
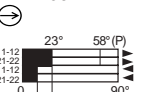
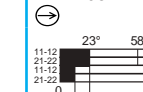



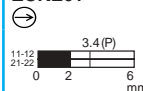
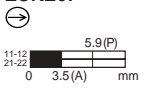
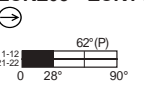
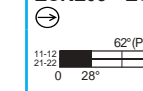



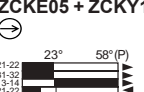
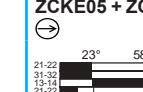

Limit switches

XC Standard range

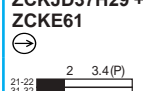
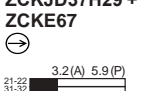
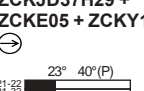
Industrial format EN 50041

Metal, conforming to CENELEC EN 50041, XCKJ

Complete fixed body switches with 1 cable entry

Type of head	Plunger (fixing by the body)		Rotary (fixing by the body) (switches supplied for actuation from left AND right)			
	Form B (1)	Form C (1)	Form A (1)			Form D (1)
						
Type of operator	Metal end plunger	Steel roller plunger	Thermoplastic roller lever (2)	Steel roller lever (2)	Variable length thermoplastic roller lever (2)	Round thermoplastic rod lever, Ø 6 mm (2) (4)
References of complete switches with 1 ISO M20 x 1.5 cable entry (3)						
 2-pole NC + NO snap action (XE2SP2151)	XCKJ161H29 	XCKJ167H29 	XCKJ10511H29 	XCKJ10513H29 	XCKJ10541H29 	XCKJ10559H29 
 2-pole NC + NO break before make, slow break (XE2NP2151)	XCKJ561H29 	XCKJ567H29 	XCKJ50511H29 	XCKJ50513H29 	XCKJ50541H29 	XCKJ50559H29 
 2-pole NC + NC snap action (XE2SP2141)	ZCKJ9H29 + ZCKE61 	ZCKJ9H29 + ZCKE67 	ZCKJ9H29 + ZCKE05 + ZCKY11 	ZCKJ9H29 + ZCKE05 + ZCKY13 	ZCKJ9H29 + ZCKE05 + ZCKY41 	ZCKJ9H29 + ZCKE05 + ZCKY59 
 2-pole NC + NC simultaneous, slow break (XE2NP2141)	ZCKJ7H29 + ZCKE61 	ZCKJ7H29 + ZCKE67 	ZCKJ7H29 + ZCKE05 + ZCKY11 	ZCKJ7H29 + ZCKE05 + ZCKY13 	ZCKJ7H29 + ZCKE05 + ZCKY41 	ZCKJ7H29 + ZCKE05 + ZCKY59 
 3-pole NC + NC + NO snap action (XE3SP2141)	ZCKJD39H29 + ZCKE61 	ZCKJD39H29 + ZCKE67 	ZCKJD39H29 + ZCKE05 + ZCKY11 	ZCKJD39H29 + ZCKE05 + ZCKY13 	ZCKJD39H29 + ZCKE05 + ZCKY41 	ZCKJD39H29 + ZCKE05 + ZCKY59 
 3-pole NC + NC + NO break before make, slow break (XE3NP2141)	ZCKJD37H29 + ZCKE61 	ZCKJD37H29 + ZCKE67 	ZCKJD37H29 + ZCKE05 + ZCKY11 	ZCKJD37H29 + ZCKE05 + ZCKY13 	ZCKJD37H29 + ZCKE05 + ZCKY41 	ZCKJD37H29 + ZCKE05 + ZCKY59 
Weight (kg)	0.430	0.455	0.480	0.490	0.485	0.485
Contact operation	 closed  open		(A) = cam displacement (P) = positive opening point		⊖ NC contact with positive opening operation	

References of complete switches with 1 Pg 13.5 cable entry (2)

For complete switches with entry for Pg 13.5 cable gland, delete H29 from the end of the reference. Example: XCKJ161H29 becomes XCKJ161.

References of complete switches with 1 entry for 1/2" NPT conduit (2)

For complete switches with entry for 1/2" NPT (USAS B2-1) conduit, replace H29 at the end of the reference by H7. Example: XCKJ161H29 becomes XCKJ161H7.

(1) Form conforming to EN 50041, see page 25.

(2) Adjustable throughout 360° in 5° steps, or in 45° steps by reversing the lever or its mounting.

(3) Switches with gold contacts or eyelet type connections: please consult our Customer Care Centre.

(4) Value taken with actuation by moving part at 100 mm from the fixing.

Limit switches

XC Standard range

Industrial format EN 50041

Metal, conforming to CENELEC EN 50041, XCKJ

Complete fixed body switches with 1 cable entry

Characteristics

Switch actuation	On end	By 30° cam			By any moving part
Type of actuation					
Maximum actuation speed	0.5 m/s	1 m/s	1.5 m/s		
Mechanical durability (1) (in millions of operating cycles)	30	25	30		
Minimum force or torque	For tripping	20 N	16 N	0.25 N.m	
	For positive opening	50 N	40 N	0.50 N.m	
Cable entry (3)	1 entry tapped M20 x 1.5 mm for ISO cable gland, clamping capacity 9 to 12 mm				

(1) Limited to 15 million operating cycles for switches with contacts XE3•P.

Dimensions

XCKJ•61H29
ZCKJ• + ZCKE61

XCKJ•67H29
ZCKJ• + ZCKE67

XCKJ•051•H29
ZCKJ• + ZCKE05 + ZCKY11 or Y13

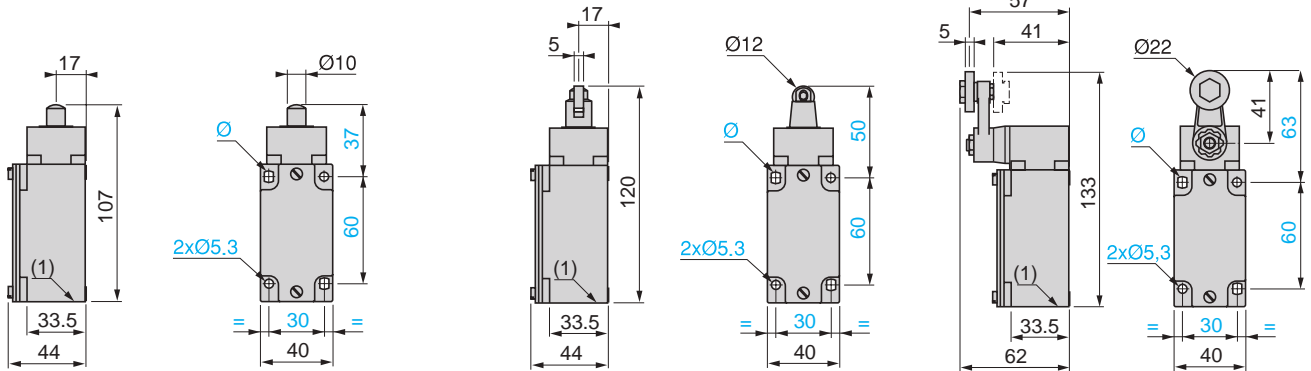

XCKJ•0541H29
ZCKJ• + ZCKE05 + ZCKY41

XCKJ•0559H29
ZCKJ• + ZCKE05 + ZCKY59

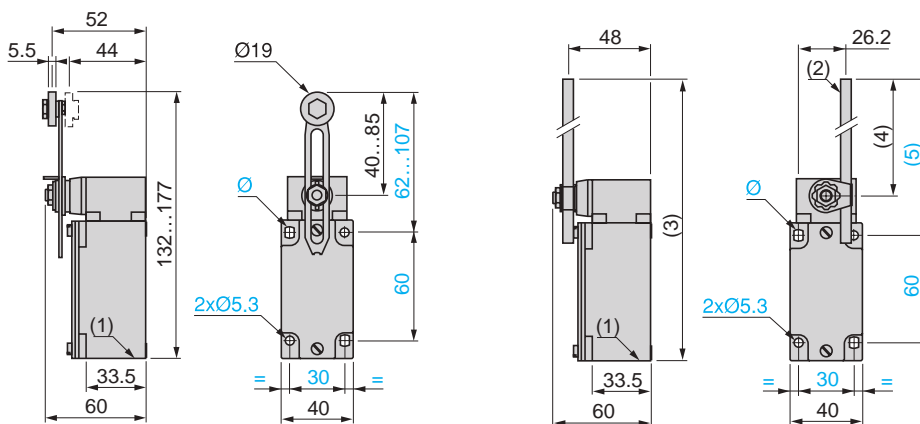

(1) 1 tapped entry for ISO M20 x 1.5 or Pg 13.5 cable gland or tapped 1/2" NPT.

(2) Ø 6 rod, length 200 mm.

(3) 282 max.





(4) 190 max.

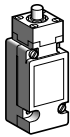
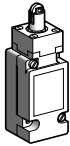

(5) 212 max.

Ø: 2 elongated holes Ø 5.3 x 7.3.

Limit switches

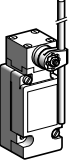

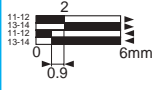
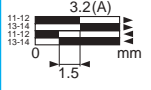
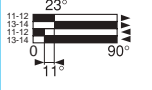
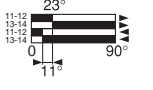
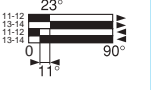
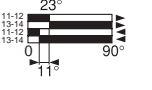
XC Standard range, industrial format EN 50041
Metal, conforming to CENELEC EN 50041, XCKJ
Complete switches, plug-in body
With 1 cable entry

Type of head	Plunger (fixing by the body)		Rotary (fixing by the body) (switches supplied for actuation from left AND right)			
	Form B (1)	Form C (1)	Form A (1)		Form D (1)	
						
Type of operator	Metal end plunger	Steel roller plunger	Thermoplastic roller lever (2)	Steel roller lever (2)	Variable length thermoplastic roller lever (2)	Round thermoplastic rod lever, Ø 6 mm (2) (4)

References of complete switches with 1 ISO M20 x 1.5 cable entry (3)						
 Single-pole CO snap action	XCKJ1161H29	XCKJ1167H29	XCKJ110511H29	XCKJ110513H29	XCKJ110541H29	XCKJ110559H29
						
Weight (kg)	0.430	0.455	0.480	0.490	0.485	0.485
Contact operation	 closed  open		(A) = cam displacement			

References of complete switches with 1 Pg 13.5 cable entry (3)
For complete switches with entry for Pg 13.5 cable gland, delete **H29** from the end of the reference.
Example: **XCKJ1161H29** becomes **XCKJ1161**.

References of complete switches with 1 entry for 1/2" NPT conduit (3)
For complete switches with entry for 1/2" NPT (USAS B2-1) conduit, replace **H29** at the end of the reference by **H7**.
Example: **XCKJ1161H29** becomes **XCKJ1161H7**.

Characteristics			
Switch actuation	On end	By 30° cam	By any moving part
Type of actuation			
Maximum actuation speed	0.5 m/s	1 m/s	1.5 m/s
Mechanical durability (in millions of operating cycles)	30	25	30
Minimum tripping force or torque	20 N	16 N	0.25 N.m
Cable entry	1 entry tapped M20 x 1.5 for ISO cable gland Clamping capacity 7 to 13 mm		

(1) Form conforming to EN 50041, see page 25.
(2) Adjustable throughout 360° in 5° steps, or in 45° steps by reversing the lever or its mounting.
(3) Switches with gold contacts: please consult our Customer Care Centre.
(4) Value taken with actuation by moving part at 100 mm from the fixing.

Limit switches

XC Standard range, industrial format EN 50041

Metal, conforming to CENELEC EN 50041, XCKJ

Complete switches, plug-in body

With 1 cable entry

Dimensions

XCKJ1161H29

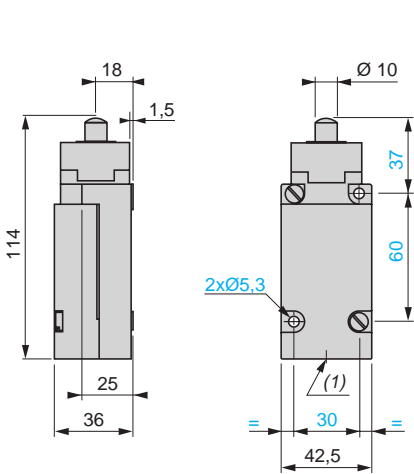

XCKJ1167H29

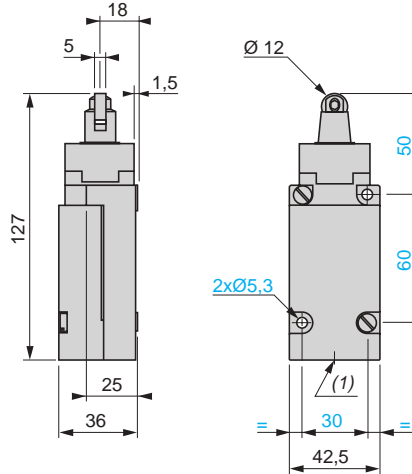

XCKJ110511H29

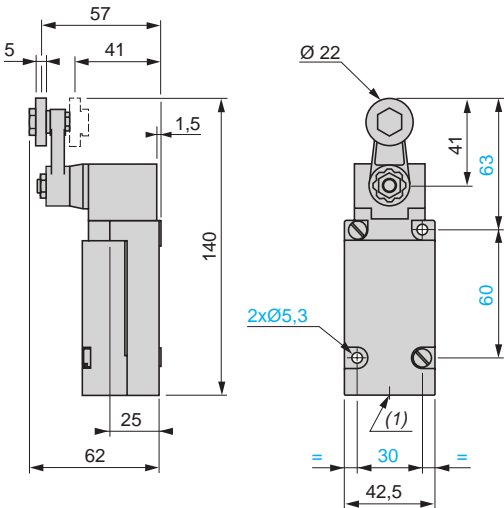

XCKJ110513H29

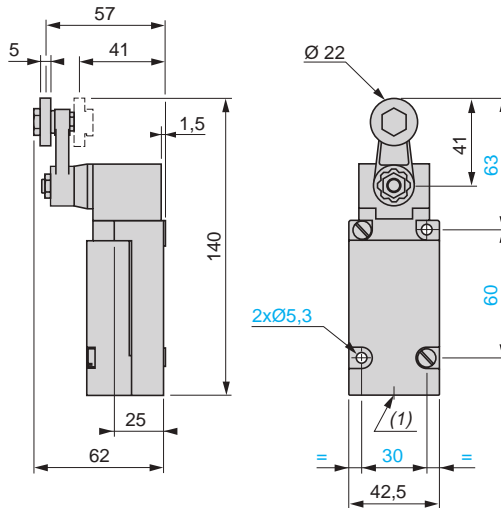

XCKJ110541H29

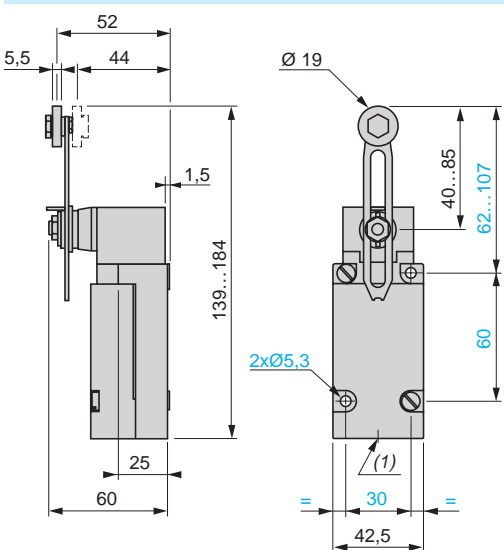

XCKJ110559H29

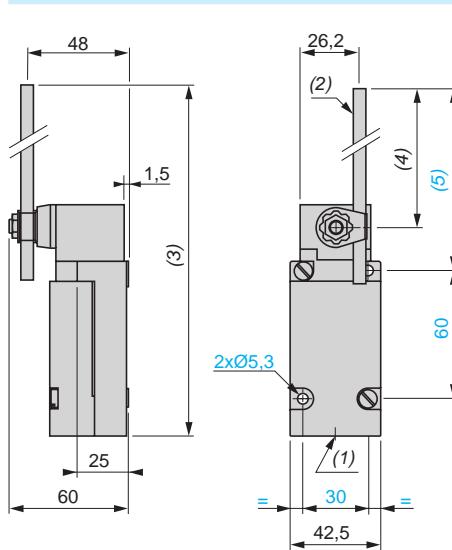

(1) 1 tapped entry for ISO M20 x 1.5 or Pg 13.5 cable gland or for 1/2" NPT conduit.

(2) Ø 6 rod, length 200 mm.

(3) 289 max.

(4) 190 max.

(5) 212 max.

Limit switches

XC Standard range, industrial format EN 50041
Metal, conforming to CENELEC EN 50041, XCKJ
Complete switches, fixed body
M12 connector

Type of head	Plunger (fixing by the body)		Rotary (fixing by the body) (switches supplied for actuation from left AND right)			
	Form B (1)	Form C (1)	Form A (1)		Form D (1)	

Type of operator	Metal end plunger	Steel roller plunger	Thermoplastic roller lever (2)	Steel roller lever (2)	Variable length thermoplastic roller lever (2)	Round thermoplastic rod lever, Ø 6 mm (2) (3)
------------------	-------------------	----------------------	--------------------------------	------------------------	--	---

References (4)	2-pole NC + NO snap action (XE2SP2151)					
	XCKJ161D	XCKJ167D	XCKJ10511D	XCKJ10513D	XCKJ10541D	XCKJ10559D
Weight (kg)	0.430	0.455	0.480	0.490	0.485	0.485
Contact operation			(A) = cam displacement (P) = positive opening point			

Characteristics					
Switch actuation	On end	By 30° cam		By any moving part	
Type of actuation					
Maximum actuation speed	0.5 m/s	1 m/s	1.5 m/s		
Mechanical durability (in millions of operating cycles)	30	25	30		
Minimum force or torque	For tripping	20 N	16 N	0.25 N.m	
	For positive opening	50 N	40 N	0.50 N.m	
Connection	M12 connector, U _i = 60 V, I _e = 4 A (see suitable pre-wired female connectors below).				

- (1) Form conforming to EN 50041, see page 25.
- (2) Adjustable throughout 360° in 5° steps, or in 45° steps by reversing the lever or its mounting.
- (3) Value taken with actuation by moving part at 100 mm from the fixing.
- (4) Switches with gold contacts: please consult our Customer Care Centre.

References of suitable pre-wired female connectors			
Type of connector	M12 straight, 5-pin, 4 A/24 V max.	M12 elbowed, 5-pin, 4 A/24 V max.	
With cable, Ø 5.8 mm (4 x 0.34 mm ² + 1 x 0.5 mm ²)	L = 2 m	XZCP1164L2	XZCP1264L2
	L = 5 m	XZCP1164L5	XZCP1264L5
	L = 10 m	XZCP1164L10	XZCP1264L10
Weight (kg)	L = 2 m	0.115	
	L = 5 m	0.270	
	L = 10 m	0.520	

Limit switches

XC Standard range, industrial format EN 50041
Metal, conforming to CENELEC EN 50041, XCKJ
Complete switches, fixed body
M12 connector

Dimensions

XCKJ161D

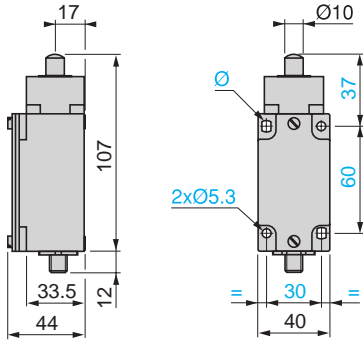

XCKJ167D

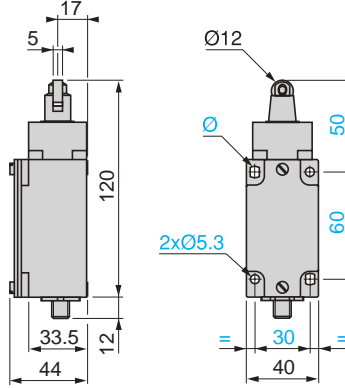

XCKJ1051●D

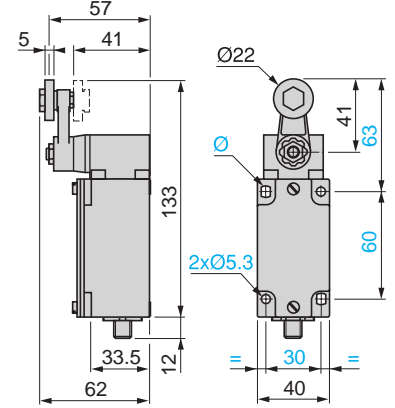

XCKJ10541D

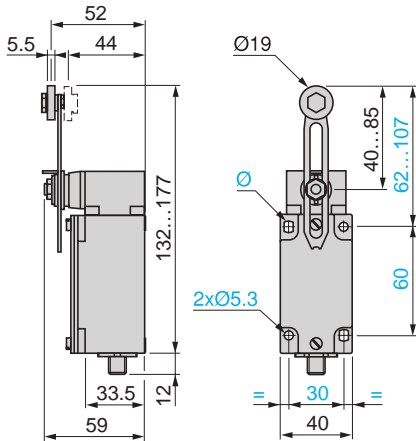

XCKJ10559D

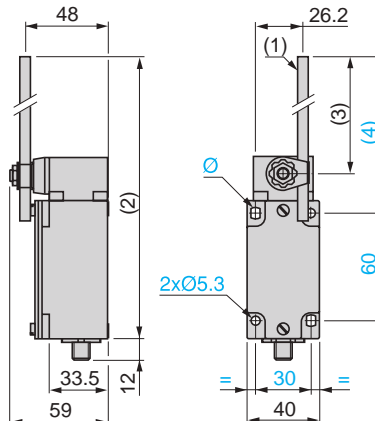

XZCP1164L●

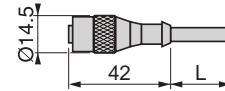

XZCP1264L●

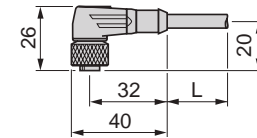

- (1) Ø 6 rod, length 200 mm.
- (2) 282 max.
- (3) 190 max.
- (4) 212 max.
- Ø: 2 elongated holes Ø 5.3 x 7.3.
- L: Cable length 2, 5 or 10 m.

Connections

Limit switch XCKJ●●●●D

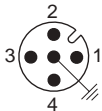

1-2 = NC
3-4 = NO
5 = \perp
4 A / 24 V max.

Pre-wired female connector XZCP1●64L●

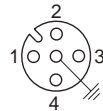



1 = brown
2 = white
3 = blue
4 = black
5 = \perp yellow/green

Limit switches

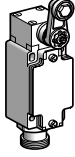
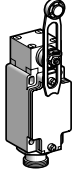
XC Standard range, industrial format EN 50041
Metal, conforming to CENELEC EN 50041, XCKJ
Complete switches, fixed body
7/8"-16UN connector

Type of head	Rotary (fixing by the body) (switches supplied for actuation from left AND right)	
	Form A (1)	
		

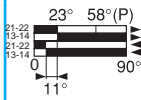
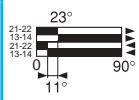
Type of operator	Steel roller lever (2)	Variable length thermoplastic roller lever (2)
-------------------------	------------------------	--

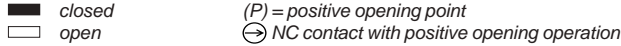
References (4)	2-pole NC + NO snap action (XE2SP2151)	XCKJ10513A 	XCKJ10541A 
			
Weight (kg)	0.490	0.485	
Contact operation			

Characteristics	
Switch actuation	By 30° cam
Type of actuation	
Maximum actuation speed	1.5 m/s
Mechanical durability (in millions of operating cycles)	30
Minimum force or torque	For tripping: 0.25 N.m For positive opening: 0.50 N.m
Connection	7/8"-16UN connector, U _i = 250 V; I _e = 6 A (see suitable pre-wired female connectors below).

(1) Form conforming to EN 50041, see page 25.
(2) Adjustable throughout 360° in 5° steps, or in 45° steps by reversing the lever or its mounting.
(3) Value taken with actuation by moving part at 100 mm from the fixing.
(4) Switches with gold contacts: please consult our Customer Care Centre.

References of suitable pre-wired female connectors		
Type of connector	7/8"-16UN straight, 5-pin, 4 A/250 V max.	
With cable, Ø 5.9 mm (5 x 0.34 mm ²)	L = 2 m	XZCP1764L2
	L = 5 m	XZCP1764L5
	L = 10 m	XZCP1764L10
Weight (kg)	L = 2 m	0.185
	L = 5 m	0.460
	L = 10 m	0.900

Limit switches

XC Standard range, industrial format EN 50041
Metal, conforming to CENELEC EN 50041, XCKJ
Complete switches, fixed body
7/8"-16UN connector

Dimensions

XCKJ1051●A

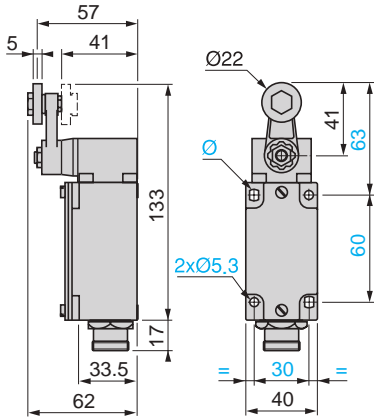

XCKJ10541A

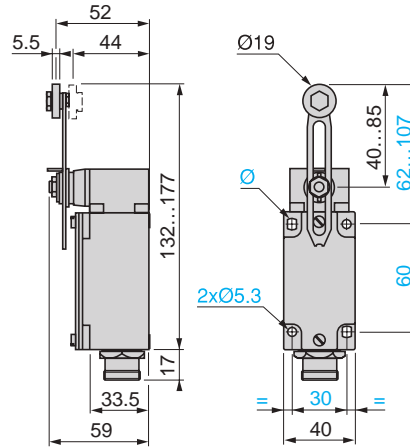

XZCP1764L●

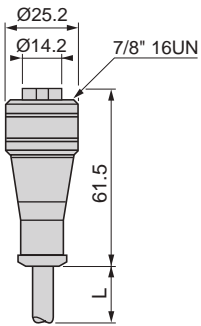

Ø: 2 elongated holes Ø 5.3 x 7.3.
L: Cable length 2, 5 or 10 m.

Connections

Limit switch XCKJ●●●●A

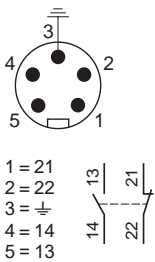

Pre-wired female connector XZCP1764L●

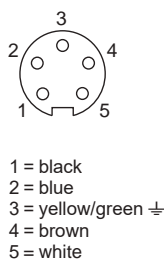

Limit switches

XC Standard range, industrial format EN 50041

Metal, conforming to CENELEC EN 50041, XCKJ

Fixed or plug-in body

Variable composition: standard bodies

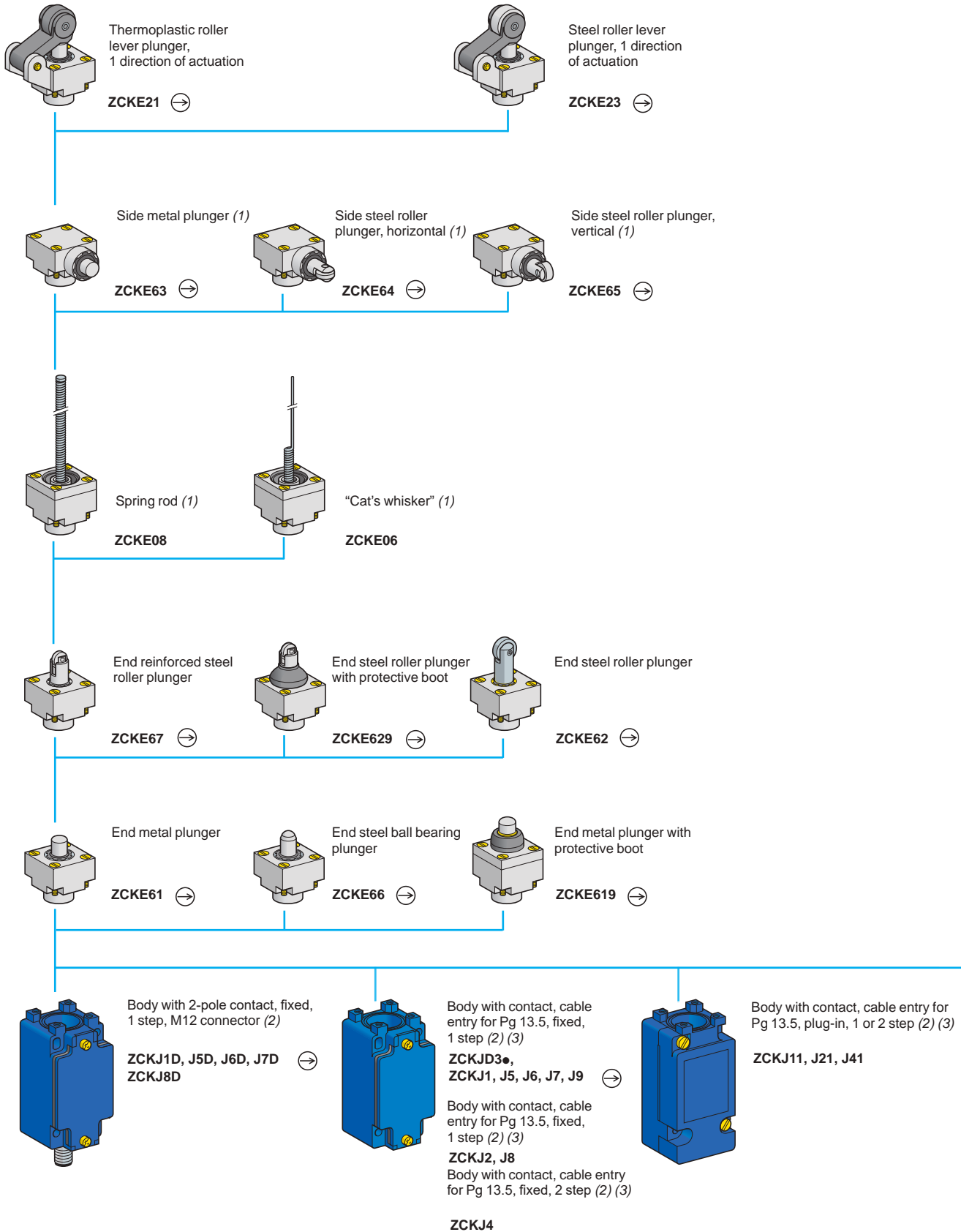

(1) Cannot be used with bodies ZCKJ4 and ZCKJ41.

(2) For further information, see page 157.

(3) For a cable entry tapped ISO M20 x 1.5, add **H29** to the reference. Example: ZCKJ1 becomes **ZCKJ1H29**.

For a cable entry tapped 1/2" NPT, add **H7** to the reference. Example: ZCKJ1 becomes **ZCKJ1H7**.

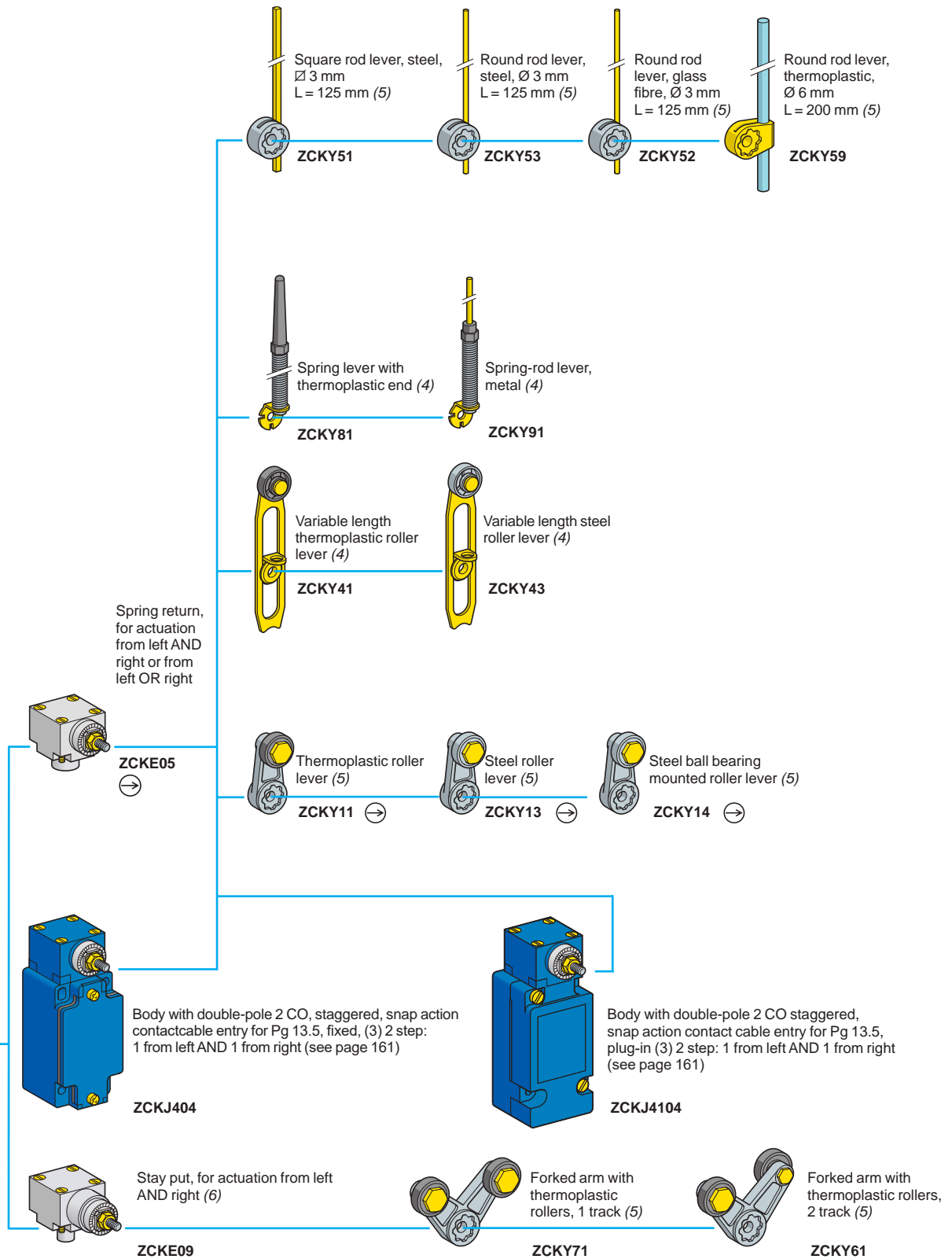

→ : head assuring positive opening operation.

(4) Adjustable throughout 360° in 5° steps, or in 90° steps by reversing the notched washer.

(5) Adjustable throughout 360° in 5° steps, or in 45° steps by reversing the lever mounting.

(6) Suitable for bodies with contacts ZCKJ1●, J2●, J31, J39.

Limit switches

XC Standard range, industrial format EN 50041

Metal, conforming to CENELEC EN 50041, XCKJ

Fixed or plug-in body

Adaptable sub-assemblies: standard bodies

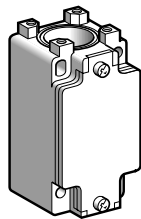

ZCKJ

Fixed bodies with 2-pole contact

Type	With contact block	Scheme	Positive operation (1)	Cable entry	Reference	Weight kg
1 step	1 NC + 1 NO snap action (XE2SP2151)		⊖	Pg 13.5	ZCKJ1	0.310
				ISO M20 x 1.5	ZCKJ1H29	0.310
				1/2" NPT	ZCKJ1H7	0.310
	2 CO simultaneous, snap action (XE2SP2021)		-	Pg 13.5	ZCKJ2	0.310
				ISO M20 x 1.5	ZCKJ2H29	0.310
				1/2" NPT	ZCKJ2H7	0.310
	1 NC + 1 NO break before make, slow break (XE2NP2151)		⊖	Pg 13.5	ZCKJ5	0.310
ISO M20 x 1.5				ZCKJ5H29	0.310	
1/2" NPT				ZCKJ5H7	0.310	
1 NO + 1 NC make before break, slow break (XE2NP2161)		⊖	Pg 13.5	ZCKJ6	0.310	
			ISO M20 x 1.5	ZCKJ6H29	0.310	
			1/2" NPT	ZCKJ6H7	0.310	
2 NC simultaneous, slow break (XE2NP2141)		⊖	Pg 13.5	ZCKJ7	0.310	
			ISO M20 x 1.5	ZCKJ7H29	0.310	
			1/2" NPT	ZCKJ7H7	0.310	
2 NO simultaneous, slow break (XE2NP2131)		-	Pg 13.5	ZCKJ8	0.310	
			ISO M20 x 1.5	ZCKJ8H29	0.310	
			1/2" NPT	ZCKJ8H7	0.310	
2 NC snap action (XE2SP2141)		⊖	Pg 13.5	ZCKJ9	0.310	
			ISO M20 x 1.5	ZCKJ9H29	0.310	
2 step	2 CO staggered snap action (XE2SP2031)		-	Pg 13.5	ZCKJ4	0.310
				ISO M20 x 1.5	ZCKJ4H29	0.310
				1/2" NPT	ZCKJ4H7	0.310

Fixed bodies with 3-pole contact

Type	With contact block	Scheme	Positive operation (1)	Cable entry	Reference	Weight kg
-	1 NC + 2 NO snap action (XE3SP2151)		⊖	Pg 13.5	ZCKJD31	0.310
				ISO M20 x 1.5	ZCKJD31H29	0.310
				1/2" NPT	ZCKJD31H7	0.310
	2 NC + 1 NO snap action (XE3SP2141)		⊖	Pg 13.5	ZCKJD39	0.310
ISO M20 x 1.5				ZCKJD39H29	0.310	
1/2" NPT				ZCKJD39H7	0.310	
2 NC + 1 NO break before make, slow break (XE3NP2141)		⊖	Pg 13.5	ZCKJD37	0.310	
			ISO M20 x 1.5	ZCKJD37H29	0.310	
			1/2" NPT	ZCKJD37H7	0.310	
1 NC + 2 NO break before make, slow break (XE3NP2151)		⊖	Pg 13.5	ZCKJD35	0.310	
			ISO M20 x 1.5	ZCKJD35H29	0.310	

(1) ⊖: NC contact with positive opening operation.

Limit switches

XC Standard range, industrial format EN 50041

Metal, conforming to CENELEC EN 50041, XCKJ

Fixed or plug-in body

Adaptable sub-assemblies: standard bodies

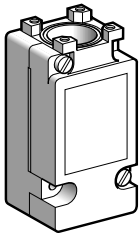

ZCKJ01

Plug-in bodies with contact

Type	With contact block	Scheme	Positive operation (1)	Cable entry	Reference	Weight kg
1 step	Single-pole 1 CO snap action		-	Pg 13.5	ZCKJ11	0.300
				ISO M20 x 1.5	ZCKJ11H29	0.300
				1/2" NPT	ZCKJ11H7	0.300
2 step	Double-pole 2 CO simultaneous, snap action		-	Pg 13.5	ZCKJ21	0.300
				ISO M20 x 1.5	ZCKJ21H29	0.300
				1/2" NPT	ZCKJ21H7	0.300
2 step	Double-pole 2 CO staggered, snap action		-	Pg 13.5	ZCKJ41	0.300
				ISO M20 x 1.5	ZCKJ41H29	0.300

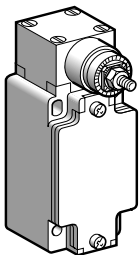

ZCKJ404

Bodies with contact, with rotary head (without operating lever)

Type	With contact block	Scheme	Positive operation (1)	Cable entry	Reference	Weight kg
Fixed body						
2 step 1 from left AND 1 from right (see page 161)	Double-pole 2 CO staggered, snap action		-	Pg 13.5	ZCKJ404	0.455
				ISO M20 x 1.5	ZCKJ404H29	0.455
				1/2" NPT	ZCKJ404H7	0.455
Plug-in body						
2 step 1 from left AND 1 from right (see page 161)	Double-pole 2 CO staggered, snap action		-	Pg 13.5	ZCKJ4104	0.465
				ISO M20 x 1.5	ZCKJ4104H29	0.465
				1/2" NPT	ZCKJ4104H7	0.465

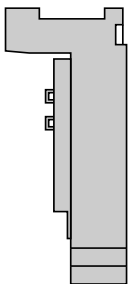

ZCKJ00

Plug-in housing only

Description	For use with	Contacts	Reference	Weight kg
Single-pole 1 CO with positive opening operation	ZCKJ11	Silver	ZCKJ01	0.150
Double-pole 2 CO with positive opening operation	ZCKJ21	Silver	ZCKJ02	0.160
Double-pole 2 CO staggered	ZCKJ41	Silver	ZCKJ04	0.160

(1) ⊖: NC contact with positive opening operation.

Limit switches

XC Standard range, industrial format EN 50041
 Metal, conforming to CENELEC EN 50041, XCKJ
 Fixed or plug-in body. Adaptable sub-assemblies:
 bodies with indicator light module

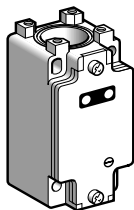

ZCKJ●●●

Fixed bodies with 2-pole contact						
Type	With contact block	Scheme	Positive operation (1)	Cable entry	Reference	Weight kg
With module comprising 1 LED, 24 V $\overline{\text{DC}}$						
1 step	1 NC + 1 NO snap action (XE2SP2151)		\ominus	Pg 13.5	ZCKJ120	0.320
With module comprising 2 LEDs, 24 V $\overline{\text{DC}}$						
1 step	1 NC + 1 NO snap action (XE2SP2151)		\ominus	Pg 13.5	ZCKJ121	0.320
	1 NC + 1 NO break before make, slow break (XE2NP2151)		\ominus	ISO M20 x 1.5	ZCKJ121H29	0.320
			\ominus	Pg 13.5	ZCKJ521	0.320
				ISO M20 x 1.5	ZCKJ521H29	0.320
With module comprising 2 LEDs, 110/240 V \sim						
1 step	1 NC + 1 NO snap action (XE2SP2151)		\ominus	Pg 13.5	ZCKJ134	0.320

Plug-in bodies with single-pole contact						
Type	With contact block	Scheme	Positive operation (1)	Cable entry	Reference	Weight kg
With module comprising 2 LEDs, 24 V $\overline{\text{DC}}$						
1 step	CO snap action		-	Pg 13.5	ZCKJ1121	0.340
				ISO M20 x 1.5	ZCKJ1121H29	0.340

(1) \ominus : NC contact with positive opening operation.

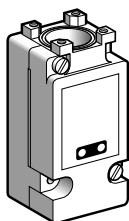

ZCKJ1●●●

Indicator light module characteristics		
Type of indicator	1 LED or 2 LEDs	2 LEDs
Rated insulation voltage	50 V $\overline{\text{DC}}$, conforming to IEC 60947-1	250 V \sim , conforming to IEC 60947-1
Current consumption	7 mA per LED	9 mA per LED
Rated operational voltage	24 V $\overline{\text{DC}}$	110/240 V \sim
Voltage limits	20...30 V $\overline{\text{DC}}$ (including ripple)	95...264 V \sim
Service life	100 000 hours	100 000 hours
Reverse polarity protection	Yes	-

Limit switches

XC Standard range, industrial format EN 50041

Metal, conforming to CENELEC EN 50041, XCKJ

Fixed or plug-in body. Adaptable sub-assemblies:
bodies with M12 connector

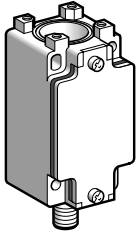

ZCKJ•D

Fixed bodies with 2-pole contact

Type	With contact block	Scheme	Positive operation (1)	Reference	Weight kg
1 step	1 NC + 1 NO snap action (XE2SP2151)			ZCKJ1D	0.320
	1 NC + 1 NO break before make, slow break (XE2NP2151)			ZCKJ5D	0.320
	1 NO + 1 NC make before break, slow break (XE2NP2161)			ZCKJ6D	0.320
	2 NC simultaneous, slow break (XE2NP2141)			ZCKJ7D	0.320
	2 NO simultaneous, slow break (XE2NP2131)		-	ZCKJ8D	0.320

Female pre-wired connectors

Description	Cable length	Reference	Weight kg
Female pre-wired connectors, M12, straight Ø 5,0 mm cable Conductor c.s.a: 5 x 0.34 mm ² Nominal current : 4 A Nominal voltage: ~ 30 V, ~ 36 V	1 m	XZCP1164L2	0.115
	5 m	XZCP1164L5	0.270
	10 m	XZCP1164L10	0.520

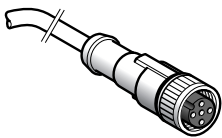

XZCP1164L•

(1) NC contact with positive opening operation.

Limit switches

XC Standard range, industrial format EN 50041

Metal, conforming to CENELEC EN 50041, XCKJ

Fixed or plug-in body

Adaptable sub-assemblies: contact blocks



XE2SP21●1

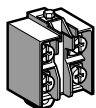

XE2NP21●1

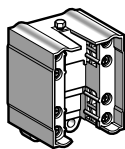

XE3P21●1

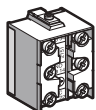

XE3●P21●1

Contact blocks						
Type of contact	Scheme	For bodies	Positive operation (1)	Reference	Weight kg	
2-pole contact						
1 NC + 1 NO snap action		ZCKJ1 ZCKJ1D	⊖	XE2SP2151	0.020	
1 NC + 1 NO break before make, slow break		ZCKJ5 ZCKJ5D	⊖	XE2NP2151	0.020	
2 CO simultaneous snap action		ZCKJ2	-	XE2SP2021	0.045	
2 CO staggered, snap action		ZCKJ4	-	XE2SP2031	0.045	
1 NO + 1 NC make before break, slow break		ZCKJ6 ZCKJ6D	⊖	XE2NP2161	0.020	
2 NC simultaneous, slow break		ZCKJ7 ZCKJ7D	⊖	XE2NP2141	0.020	
2 NO simultaneous, slow break		ZCKJ8 ZCKJ8D	-	XE2NP2131	0.020	
2 NC snap action		ZCKJ9	⊖	XE2SP2141	0.020	
3-pole contact						
1 NC + 2 NO snap action		ZCKJD31	⊖	XE3SP2151	0.035	
2 NC + 1 NO snap action		ZCKJD39	⊖	XE3SP2141	0.035	
2 NC + 1 NO break before make, slow break		ZCKJD37	⊖	XE3NP2141	0.035	
1 NC + 2 NO break before make, slow break		ZCKJD35	⊖	XE3NP2151	0.035	

(1) ⊖: NC contact with positive opening operation.

Limit switches

XC Standard range, industrial format EN 50041

Metal, conforming to CENELEC EN 50041, XCKJ

Fixed or plug-in body

Adaptable sub-assemblies: add-ons

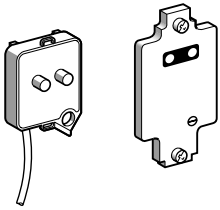

ZCKZ0●●

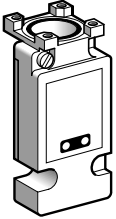

ZCKJ01●●

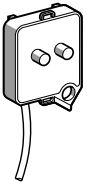

ZCKJ90●

Covers + indicator light module

For use with	Number and type of indicators	Voltage	Reference	Weight kg
Fixed body	1 LED	24 V $\overline{\text{---}}$	ZCKZ020	0.060
	2 LEDs	24 V $\overline{\text{---}}$	ZCKZ021	0.060
	2 LEDs	110/240 V \sim	ZCKZ034	0.060
Plug-in body	2 LEDs	24 V $\overline{\text{---}}$	ZCKJ0121	0.200

Indicator light modules

For use with	Number and type of indicators	Voltage	Reference	Weight kg
Fixed body	1 LED	24 V $\overline{\text{---}}$	ZCKJ902	0.030
	2 LEDs	24 V $\overline{\text{---}}$	ZCKJ906	0.030

Other versions

Covers + indicator light module for other supply voltages.
Please consult our Customer Care Centre.

Limit switches

XC Standard range, industrial format EN 50041
 Metal, conforming to CENELEC EN 50041, XCKJ
 Fixed or plug-in body
 Adaptable sub-assemblies

Function diagrams (positive operation assured only if the associated sub-assemblies are)

Heads ZCKE61, ZCKE619, ZCKE66 with body

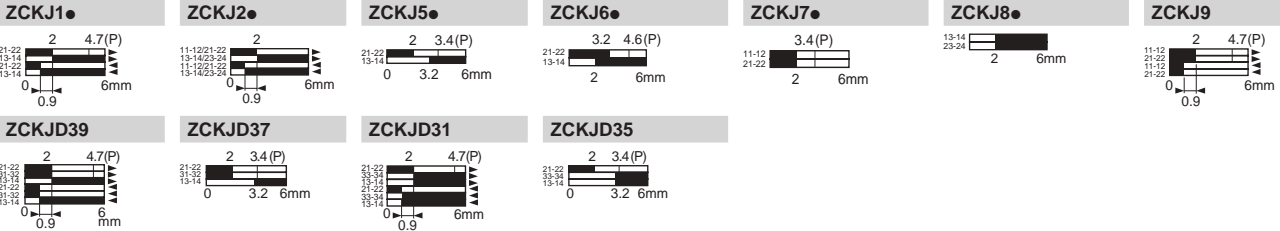

Head ZCKE63 with body

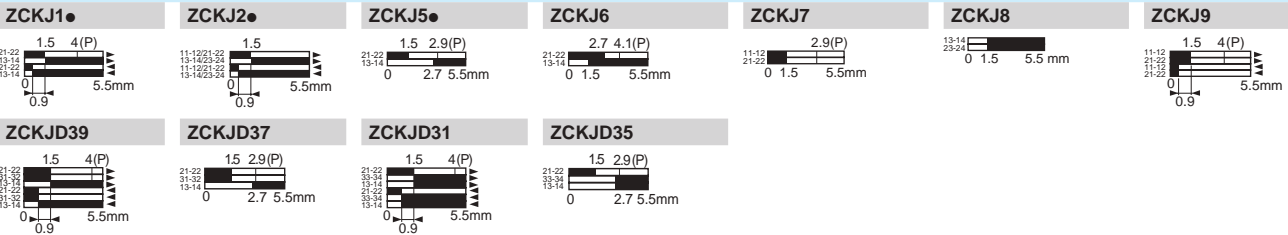

Heads ZCKE64, ZCKE65 with body

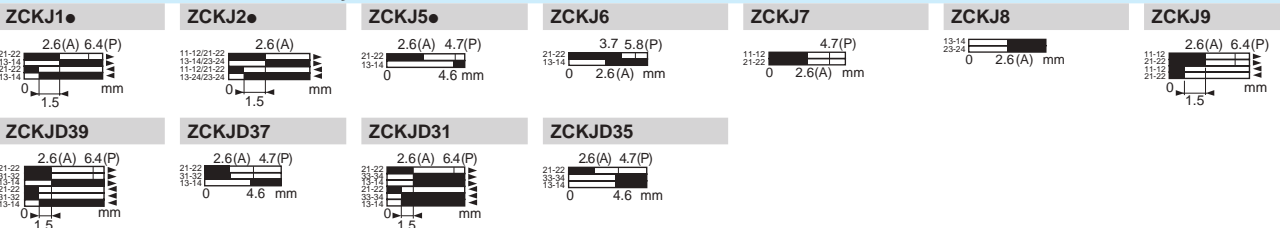

Heads ZCKE67, ZCKE629 with body

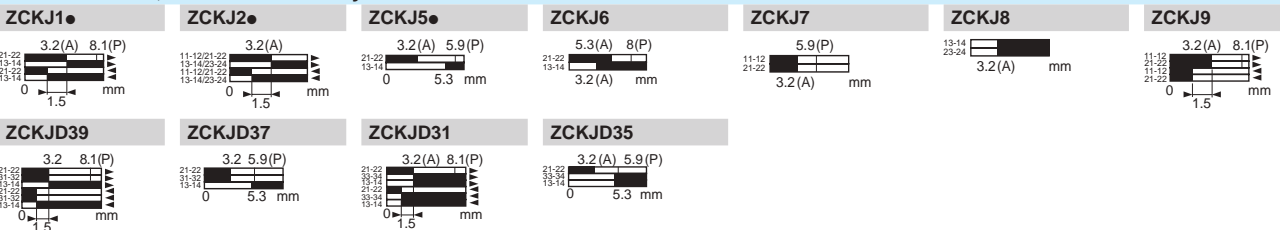

Heads ZCKE21, ZCKE23 with body

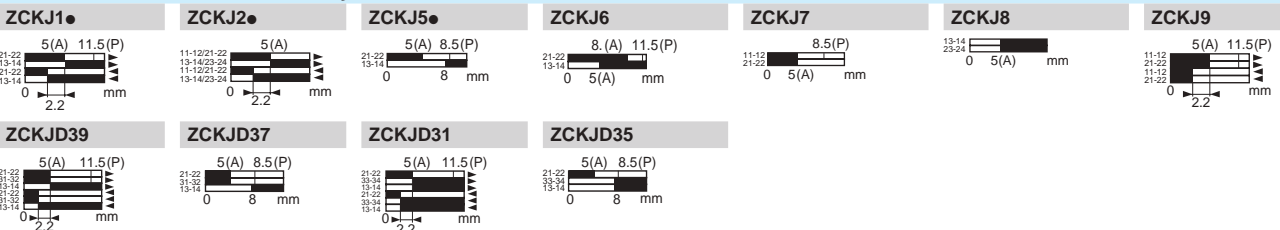

Heads ZCKE06, ZCKE08 with body

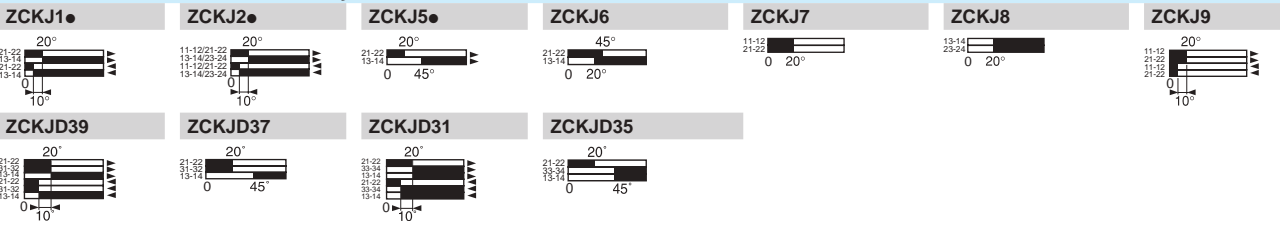

ZCKJ4

Unactuated

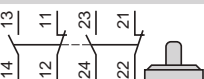

1st step

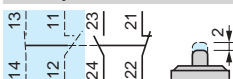

2nd step

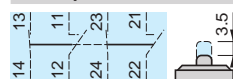

Contact operation

 closed
 open

(A) = cam displacement
 (P) = positive opening point

Limit switches

XC Standard range, industrial format EN 50041
Metal, conforming to CENELEC EN 50041, XCKJ
Fixed or plug-in body
Adaptable sub-assemblies

Function diagrams (positive operation assured only if the associated sub-assemblies are)

Head ZCKE05 with body

ZCKJ1●

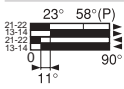

ZCKJ2●

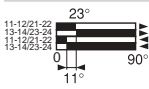

ZCKJ5●

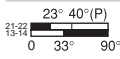

ZCKJ6

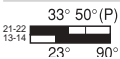

ZCKJ7

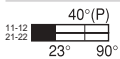

ZCKJ8



ZCKJ9

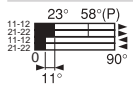

ZCKJD39

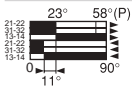

ZCKJD37

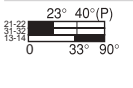

ZCKJD39

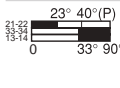

ZCKJD31

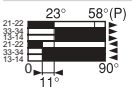

ZCKJ4●

Unactuated

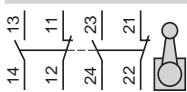

1st step, actuated from left or right

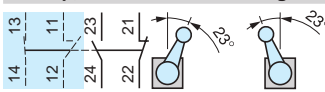

2nd step, actuated from left or right

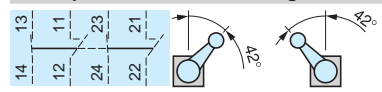

Head ZCKE09 with body

ZCKJ1●

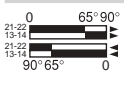

ZCKJ2●

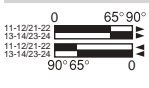

ZCKJD31

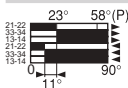

ZCKJD39

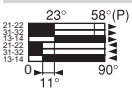

ZCKJ404, J4104 (body with head)

Unactuated

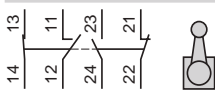

Actuated from left

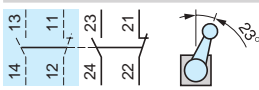

Actuated from right

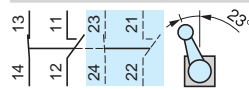

Contact operation

 closed
 open

(P) = positive opening point

Wiring schemes

Indicator light modules

1 LED, 24 V $\overline{\text{DC}}$

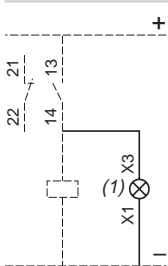

2 LEDs, 24 V $\overline{\text{DC}}$

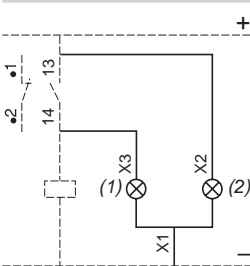

2 LEDs, 110/240 V \sim

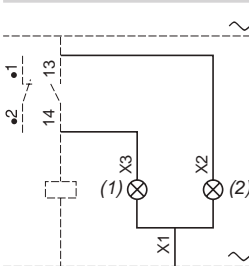

Module with resistor

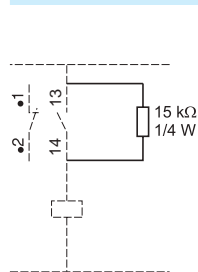

(1) Orange indicator
(2) Green indicator

ZCKJ●D

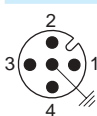

1 - 2 = NC
3 - 4 = NO
5 = \perp
4 A / 24 V max.



Pre-wired connectors XZCP1164●

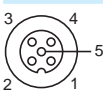

1 = brown
2 = white/black
3 = blue
4 = black
5 = yellow/green

Limit switches

XC Standard range, industrial format EN 50041
 Metal, conforming to CENELEC EN 50041, XCKJ
 Fixed or plug-in body
 Adaptable sub-assemblies

Bodies

ZCKJ1, J2, J5, J4, J●2●, J●3●, J6, J7, J8, J9
 ZCKJ1H29, J2H29, J5H29, J4H29, J●2●H29, J●3●H29,
 J6H29, J7H29, J8H29, J9H29
 ZCKJ1H7, J2H7, J5H7, J4H7, J●2●H7, J●3●H7, J6H7,
 J7H7, J8H7, J9H7

ZCKJ11, J21, J41, J11●●
 ZCKJ11H29, J21H29, J41H29, J11●●H29
 ZCKJ11H7, J21H7, J41H7, J11●●H7

ZCKJ1D, J5D, J6D, J7D, J8D

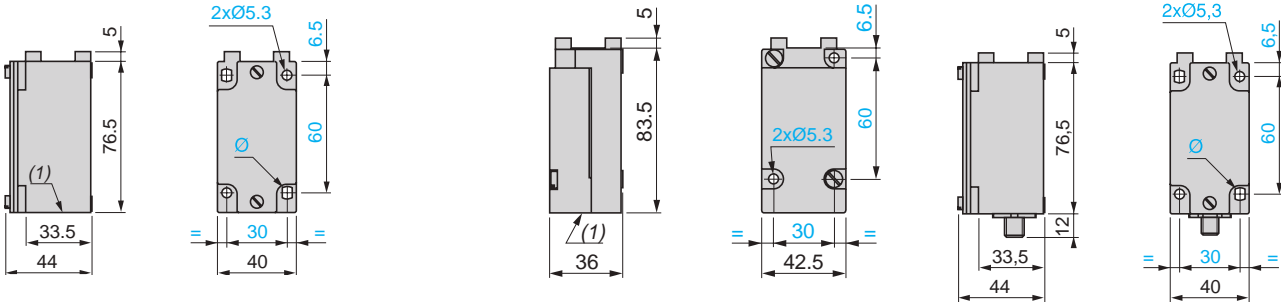

Bodies with rotary head mounted

ZCKJ404, ZCKJ404H29, ZCKJ404H7

ZCKJ4104, ZCKJ4104H29, ZCKJ4104H7

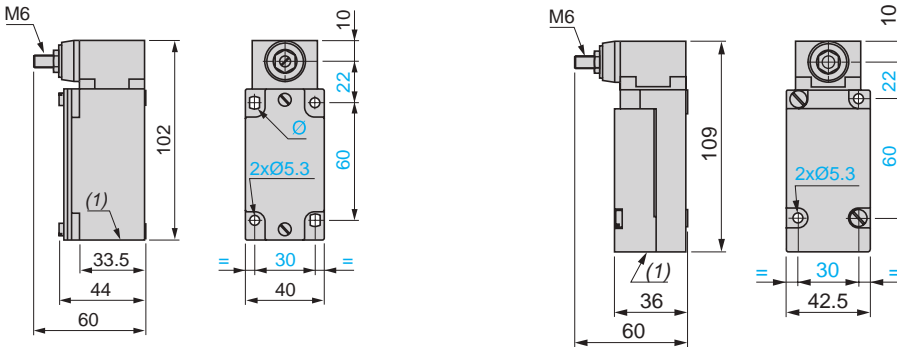

Plunger heads

ZCKE61

ZCKE619

ZCKE63

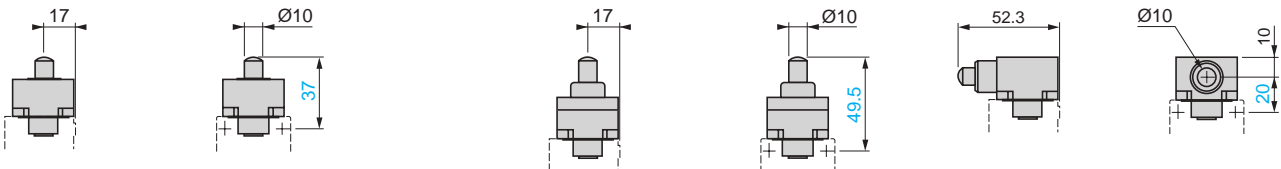

ZCKE64

ZCKE65

ZCKE66

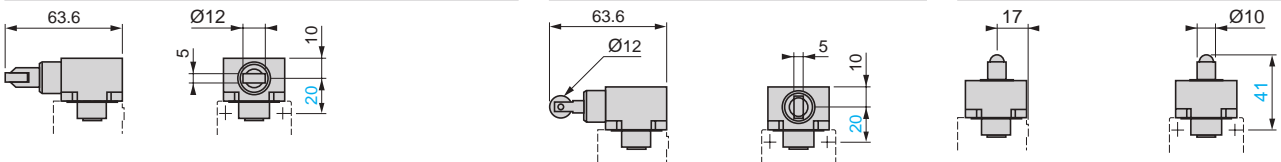

ZCKE62, ZCKE67

ZCKE629

ZCKE21, ZCKE23

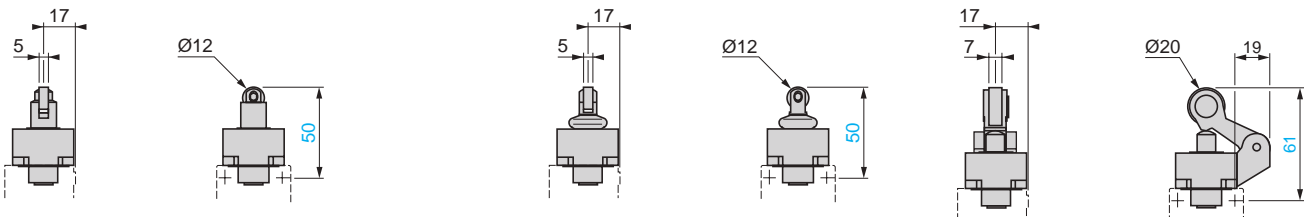

(1) 1 tapped entry for ISO M20 x 1.5 or Pg 13.5 cable gland or tapped 1/2" NPT.
 Ø: 2 elongated holes Ø 5.3 x 7.3.

Limit switches

XC Standard range, industrial format EN 50041
 Metal, conforming to CENELEC EN 50041, XCKJ
 Fixed or plug-in body
 Adaptable sub-assemblies

Rotary head ZCKE05 with operating lever

ZCKY11, ZCKY13, ZCKY14

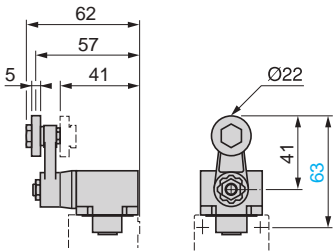

ZCKY41, ZCKY43

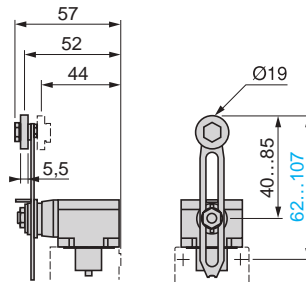

ZCKY51, ZCKY52, ZCKY53, ZCKY59

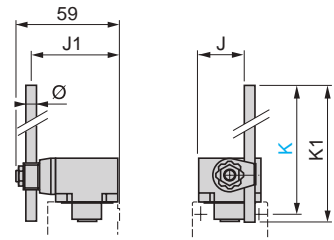

	J	J1	K max.	K1	Ø
ZCKY51	20	49	137	123	∅ 3
ZCKY52	20	49	137	125	∅ 3
ZCKY53	20	49	137	125	∅ 3
ZCKY59	26.2	48	212	200	∅ 6

ZCKY81

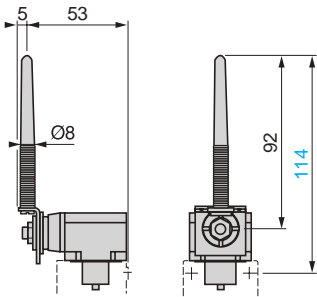

ZCKY91

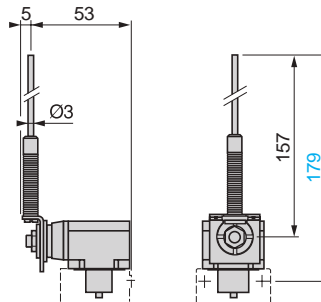

Rotary head ZCKE09 with operating lever

ZCKY61

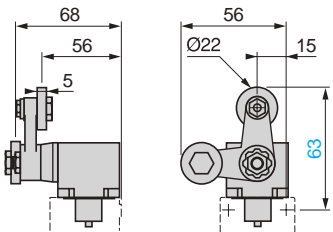

ZCKY71

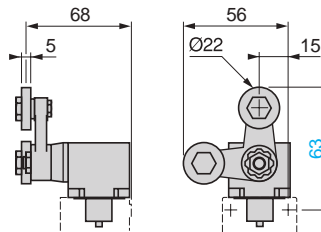

Multi-directional heads

ZCKE06

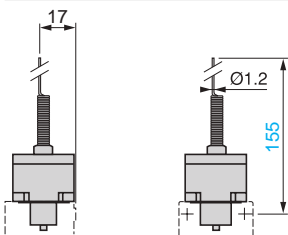

ZCKE08

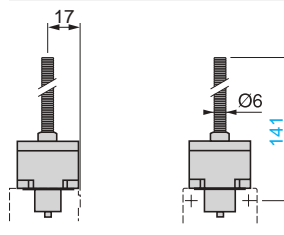

Note: operating lever spindle threaded M6.

Pre-wired connectors XZCP1164L

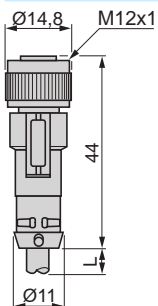

L = 2, 5 or 10 m.

Limit switches

XC Standard range, industrial format EN 50041

Metal, conforming to CENELEC EN 50041, XCKJ

Fixed or plug-in body

Adaptable sub-assemblies for low temperature applications (- 40°C)

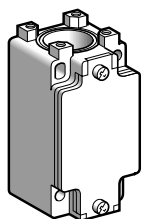

ZCKJ1

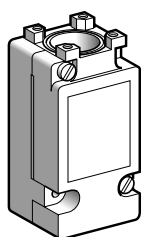

ZCKJ11

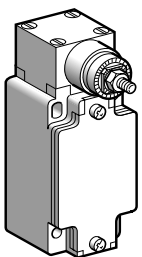

ZCKJ4046

Bodies with contacts for plunger or rotary head

Type	With contact block	Scheme	Positive operation (1)	Cable entry	Reference	Weight kg	
Fixed bodies							
1 step	2-pole NC + NO snap action (XE2SP2151)		⊕	Pg 13.5	ZCKJ1	0.310	
				ISO M20 x 1.5	ZCKJ1H29	0.310	
				1/2" NPT	ZCKJ1H7	0.310	
	Double-pole 2 CO simultaneous, snap action (XESP2021)		-	Pg 13.5	ZCKJ2	0.310	
				ISO M20 x 1.5	ZCKJ2H29	0.310	
				1/2" NPT	ZCKJ2H7	0.310	
	2-pole NC + NO break before make, slow break (XE2NP2151)		⊕	Pg 13.5	ZCKJ5	0.310	
ISO M20 x 1.5				ZCKJ5H29	0.310		
1/2" NPT				ZCKJ5H7	0.310		
2-pole NO + NC make before break, slow break (XE2NP2161)		⊕	Pg 13.5	ZCKJ6	0.310		
			ISO M20 x 1.5	ZCKJ6H29	0.310		
			1/2" NPT	ZCKJ6H7	0.310		
2-pole NC + NC simultaneous, slow break (XE2NP2141)		⊕	Pg 13.5	ZCKJ7	0.310		
			ISO M20 x 1.5	ZCKJ7H29	0.310		
			1/2" NPT	ZCKJ7H7	0.310		
2-pole NO + NO simultaneous, slow break (XE2NP2131)		-	Pg 13.5	ZCKJ8	0.310		
			ISO M20 x 1.5	ZCKJ8H29	0.310		
			1/2" NPT	ZCKJ8H7	0.310		
2-pole NC + NC snap action (XE2SP2141)		⊕	Pg 13.5	ZCKJ9	0.310		
			ISO M20 x 1.5	ZCKJ9H29	0.310		
			2 step		Double-pole 2 CO staggered, snap action (XESP2031)		-
		ISO M20 x 1.5	ZCKJ4H29	0.310			
		1/2" NPT	ZCKJ4H7	0.310			

Plug-in bodies

1 step	Single-pole CO snap action		-	Pg 13.5	ZCKJ11	0.300	
				ISO M20 x 1.5	ZCKJ11H29	0.300	
				1/2" NPT	ZCKJ11H7	0.300	
	Double-pole 2 CO simultaneous snap action		-	Pg 13.5	ZCKJ21	0.300	
				ISO M20 x 1.5	ZCKJ21H29	0.300	
				1/2" NPT	ZCKJ21H7	0.300	
2 step		Double-pole 2 CO staggered, snap action		-	Pg 13.5	ZCKJ41	0.300
		ISO M20 x 1.5			ZCKJ41H29	0.300	

Bodies with contacts With spring return rotary head (without operating lever)

Type	With contact block	Scheme	Positive operation (1)	Cable entry	Reference	Weight kg
Fixed body						
2 step 1 from the left AND 1 from the right	Double-pole 2 CO staggered, snap action		-	Pg 13.5	ZCKJ4046	0.455
				ISO M20 x 1.5	ZCKJ4046H29	0.455
Plug-in body						
2 step 1 from the left AND 1 from the right	Double-pole 2 CO staggered, snap action		-	ISO M20 x 1.5	ZCKJ41046H29	0.465

(1) ⊕: head assuring positive opening operation.

Limit switches

XC Standard range, industrial format EN 50041

Metal, conforming to CENELEC EN 50041, XCKJ

Fixed or plug-in body

Adaptable sub-assemblies for low temperature applications (- 40°C)

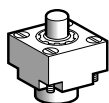

ZCKE616

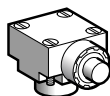

ZCKE636

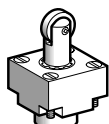

ZCKE626

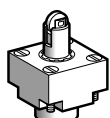

ZCKE676

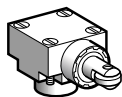

ZCKE646

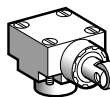

ZCKE656

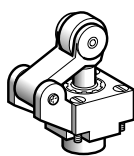

ZCKE216

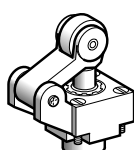

ZCKE236

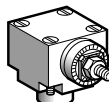

ZCKE056

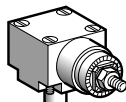

ZCKE096

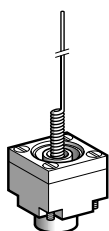

ZCKE066

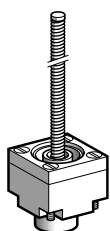

ZCKE086

Plunger heads

Type of operator	Compatible bodies	Maximum actuation speed	Positive operation (1)	Reference	Weight kg	
For actuation on end						
End plunger metal	ZCKJ●, ZCKJ●●	0.5 m/s	⊕	ZCKE616	0.140	
Side plunger metal	ZCKJ●, ZCKJ●●, except ZCKJ4 and J41	0.5 m/s	⊕	ZCKE636	0.200	
For actuation by 30° cam						
Roller plunger steel	ZCKJ●, ZCKJ●●	1 m/s	⊕	ZCKE626	0.155	
End reinforced roller plunger steel	ZCKJ●, ZCKJ●●	1 m/s	⊕	ZCKE676	0.155	
Side roller plunger steel	Horizontal	ZCKJ●, ZCKJ●●, except ZCKJ4 and J41	0.6 m/s	⊕	ZCKE646	0.205
	Vertical	ZCKJ●, ZCKJ●●, except ZCKJ4 and J41	0.6 m/s	⊕	ZCKE656	0.205
Roller lever plunger (1 direction of actuation)	Thermoplastic	ZCKJ●, ZCKJ●●	1.5 m/s	⊕	ZCKE216	0.185
	Steel	ZCKJ●, ZCKJ●●	1.5 m/s	⊕	ZCKE236	0.195

Rotary heads (without operating lever)

Type	Compatible bodies	Maximum actuation speed	Positive operation (1)	Reference	Weight kg
Spring return, for actuation from left AND right or from left OR right (see page 25)	ZCKJ●, ZCKJ●●	1.5 m/s by 30° cam	⊕	ZCKE056	0.165
Stay put, for actuation from left AND right (see page 25)	ZCKJ1, J11 ZCKJ2, J21	0.5 m/s	–	ZCKE096	0.190

Multi-directional heads

Type of operator	Compatible bodies	Maximum actuation speed	Positive operation (1)	Reference	Weight kg
For actuation by any moving part					
"Cat's whisker"	ZCKJ●, ZCKJ●●, except ZCKJ4 and ZCKJ41	1 m/s in any direction	–	ZCKE066	0.115
Spring rod	ZCKJ●, ZCKJ●●, except ZCKJ4 and ZCKJ41	0.5 m/s in any direction	–	ZCKE086	0.125

(1) ⊕: head assuring positive opening operation.

Limit switches

XC Standard range, industrial format EN 50041

Metal, conforming to CENELEC EN 50041, XCKJ

Fixed or plug-in body

Adaptable sub-assemblies for low temperature applications (- 40°C)



ZCKY1●

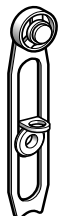

ZCKY4●



ZCKY51

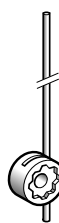

ZCKY5●

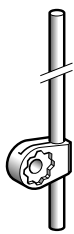

ZCKY59



ZCKY81

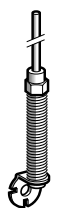

ZCKY91

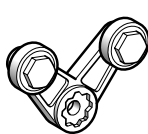

ZCKY71



ZCKY61

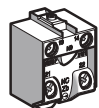

XE2SP21●1

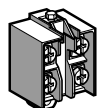

XE2NP21●1

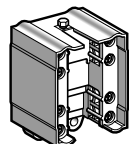

XES P20●1

Operating levers for rotary heads

Description		Positive operation (1)	Reference	Weight kg
For actuation by 30° cam				
Roller lever (2)	Thermoplastic	⊕	ZCKY11	0.025
	Steel	⊕	ZCKY13	0.035
	Steel, ball bearing mounted	⊕	ZCKY14	0.030
Variable length roller lever (3)	Thermoplastic	-	ZCKY41	0.030
	Steel	-	ZCKY43	0.040

For actuation by any moving part

Square rod (2)	∅ 3 mm steel, L = 125 mm	-	ZCKY51	0.025
Round rod (2)	∅ 3 mm steel, L = 125 mm	-	ZCKY53	0.025
	∅ 3 mm glass fibre, L = 125 mm	-	ZCKY52	0.020
	∅ 6 mm thermoplastic, L = 200 mm	-	ZCKY59	0.030
Spring lever (3)		-	ZCKY81	0.020
Spring-metal rod lever (3)		-	ZCKY91	0.025

For actuation by specific cam (only for operation with head ZCKE096)

Forked arm with rollers (2)	1 track	-	ZCKY71	0.035
	2 track	-	ZCKY61	0.035

2-pole and double-pole contact blocks

Type of contact	Scheme	For body	Positive operation (1)	Reference	Weight kg
NC + NO snap action		ZCKJ1	⊕	XE2SP2151	0.020
NC + NO break before make, slow break		ZCKJ5	⊕	XE2NP2151	0.020
2 CO simultaneous, snap action		ZCKJ2	-	XESP2021	0.045
2 CO staggered, snap action		ZCKJ4	-	XESP2031	0.045
NC + NO make before break, slow break		ZCKJ6	⊕	XE2NP2161	0.020
NC + NC simultaneous, slow break		ZCKJ7	⊕	XE2NP2141	0.020
NO + NO simultaneous, slow break		ZCKJ8	-	XE2NP2131	0.020
NC + NC snap action		ZCKJ9	⊕	XE2SP2141	0.020

(1) ⊕: NC contact with positive opening operation or sub-assembly assuring positive opening operation.

(2) Adjustable throughout 360° in 5° steps, or in 45° steps by reversing the lever or its mounting.

(3) Adjustable throughout 360° in 5° steps.

Limit switches

XC Standard range, industrial format EN 50041

Metal, conforming to CENELEC EN 50041, XCKJ

Fixed or plug-in body

Adaptable sub-assemblies for high temperature applications (+ 120°C)

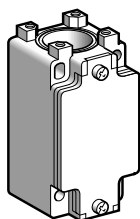

ZCKJ

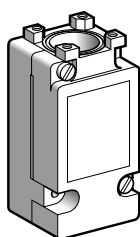

ZCKJ15

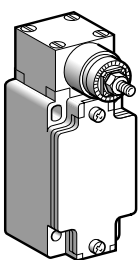

ZCKJ4045

Bodies with contacts		For plunger or rotary head				
Type	With contact block	Scheme	Positive operation (1)	Cable entry	Reference	Weight kg
Fixed bodies						
1 step	2-pole NC + NO snap action (XE2SP2151)		⊕	Pg 13.5	ZCKJ1	0.310
				ISO M20 x 1.5	ZCKJ1H29	0.310
				1/2" NPT	ZCKJ1H7	0.310
	Double-pole 2 CO simultaneous, snap action (XESP20215)		-	Pg 13.5	ZCKJ25	0.310
				ISO M20 x 1.5	ZCKJ25H29	0.310
				1/2" NPT	ZCKJ25H7	0.310
	2-pole NC + NO break before make, slow break (XE2NP2151)		⊕	Pg 13.5	ZCKJ5	0.310
				ISO M20 x 1.5	ZCKJ5H29	0.310
				1/2" NPT	ZCKJ5H7	0.310
2-pole NO + NC make before break, slow break (XE2NP2161)		⊕	Pg 13.5	ZCKJ6	0.310	
			ISO M20 x 1.5	ZCKJ6H29	0.310	
			1/2" NPT	ZCKJ6H7	0.310	
2-pole NC + NC simultaneous, slow break (XE2NP2141)		⊕	Pg 13.5	ZCKJ7	0.310	
			ISO M20 x 1.5	ZCKJ7H29	0.310	
			1/2" NPT	ZCKJ7H7	0.310	
2-pole NO + NO simultaneous, slow break (XE2NP2131)		-	Pg 13.5	ZCKJ8	0.310	
			ISO M20 x 1.5	ZCKJ8H29	0.310	
			1/2" NPT	ZCKJ8H7	0.310	
2-pole NC + NC snap action (XE2SP2141)		⊕	Pg 13.5	ZCKJ9	0.310	
			ISO M20 x 1.5	ZCKJ9H29	0.310	
2 step	Double-pole 2 CO staggered, snap action (XESP20315)		-	Pg 13.5	ZCKJ45	0.310
Plug-in bodies						
1 step	Single-pole CO snap action		-	Pg 13.5	ZCKJ115	0.300
				ISO M20 x 1.5	ZCKJ115H29	0.300
Double-pole 2 CO simultaneous, snap action		-	Pg 13.5	ZCKJ215	0.300	
			ISO M20 x 1.5	ZCKJ215H29	0.300	
			1/2" NPT	ZCKJ215H7	0.300	
2 step	Double-pole 2 CO staggered, snap action		-	Pg 13.5	ZCKJ415	0.300
Bodies with contacts		With spring return rotary head (without operating lever)				
Type	With contact block	Scheme	Positive operation (1)	Cable entry	Reference	Weight kg
Fixed body						
2 step 1 from the left AND 1 from the right	Double-pole 2 CO staggered, snap action		-	Pg 13.5	ZCKJ4045	0.455
				ISO M20 x 1.5	ZCKJ4045H29	0.455
				1/2" NPT	ZCKJ4045H7	0.455

(1) ⊕: head assuring positive opening operation.

Limit switches

XC Standard range, industrial format EN 50041

Metal, conforming to CENELEC EN 50041, XCKJ

Fixed or plug-in body

Adaptable sub-assemblies for high temperature applications (+ 120°C)

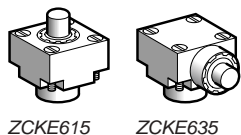

ZCKE615 ZCKE635

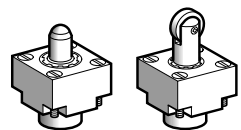

ZCKE665 ZCKE625

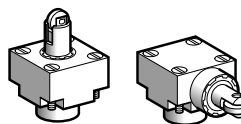

ZCKE675 ZCKE645

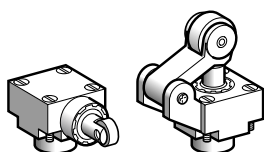

ZCKE655 ZCKE235

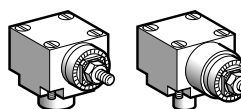

ZCKE055 ZCKE095

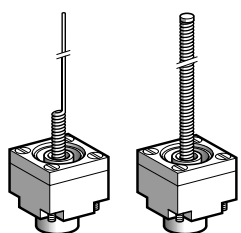

ZCKE065 ZCKE085

Plunger heads

Type of operator	Compatible bodies	Maximum actuation speed	Positive operation (1)	Reference	Weight kg
For actuation on end					
End plunger	Metal	ZCKJ1, J2, J4, ZCKJ115, J215, J415, ZCKJ5, J6, J7, J8, J9	0.5 m/s	⊕	ZCKE615 0.140
Side plunger	Metal	ZCKJ1, J2, ZCKJ115, J215, ZCKJ5, J6, J7, J8, J9	0.5 m/s	⊕	ZCKE635 0.200
For actuation by 30° cam					
End ball bearing plunger	Steel	ZCKJ1, J2, J4, ZCKJ115, J215, J415, ZCKJ5, J6, J7, J8, J9	0.1 m/s	⊕	ZCKE665 0.150
End roller plunger	Steel	ZCKJ1, J2, J4, ZCKJ115, J215, J415, ZCKJ5, J6, J7, J8, J9	1 m/s	⊕	ZCKE625 0.155
End reinforced roller plunger	Steel	ZCKJ1, J2, J4, ZCKJ115, J215, J415, ZCKJ5, J6, J7, J8, J9	1 m/s	⊕	ZCKE675 0.155
Side roller plunger	Steel Horizontal	ZCKJ1, J2, ZCKJ115, J215, ZCKJ5, J6, J7, J8, J9	0.6 m/s	⊕	ZCKE645 0.205
	Steel Vertical	ZCKJ1, J2, ZCKJ115, J215, ZCKJ5, J6, J7, J8, J9	0.6 m/s	⊕	ZCKE655 0.205
Roller lever plunger (1 direction of actuation)	Steel	ZCKJ1, J2, J4, ZCKJ115, J215, J415, ZCKJ5, J6, J7, J8, J9	1.5 m/s	⊕	ZCKE235 0.195
	Thermoplastic	ZCKJ1, J2, J4, ZCKJ115, J215, J415, ZCKJ5, J6, J7, J8, J9	1.5 m/s	⊕	ZCKE215 0.185

Rotary heads (without operating lever)

Type	Compatible bodies	Maximum actuation speed	Positive operation (1)	Reference	Weight kg
Spring return, for actuation from left AND right or from left OR right (see page 25)	ZCKJ1, J2, J4, ZCKJ115, J215, ZCKJ415, ZCKJ5, J6, J7, J8, J9	1.5 m/s by 30° cam	⊕	ZCKE055	0.165
Stay put, actuation from left AND right (see page 25)	ZCKJ1, J2, ZCKJ115, J215	0.5 m/s	–	ZCKE095	0.190

Multi-directional heads

Type of operator	Compatible bodies	Maximum actuation speed	Positive operation (1)	Reference	Weight kg
For actuation by any moving part					
“Cat’s whisker”	ZCKJ1, J2, ZCKJ115, J215, ZCKJ5, J6, J7, J8, J9	1 m/s in any direction	–	ZCKE065	0.115
Spring rod	ZCKJ1, J2, ZCKJ115, J215, ZCKJ5, J6, J7, J8, J9	0.5 m/s in any direction	–	ZCKE085	0.125

(1) ⊕: head assuring positive opening operation.

Limit switches

XC Standard range, industrial format EN 50041

Metal, conforming to CENELEC EN 50041, XCKJ

Fixed or plug-in body

Adaptable sub-assemblies for high temperature applications (+ 120°C)



ZCKY1●

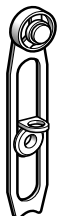

ZCKY43



ZCKY51

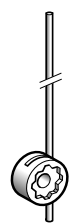

ZCKY5●

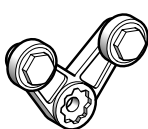

ZCKY715



ZCKY615



XE2SP21●1

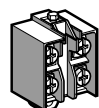

XE2NP21●1

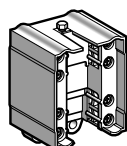

XESP20●15

Operating levers for rotary heads

Description		Positive operation (1)	Reference	Weight kg
For actuation by 30° cam				
Roller lever (2)	Thermoplastic	⊕	ZCKY115	0.025
	Steel	⊕	ZCKY13	0.035
	Steel, ball bearing mounted	⊕	ZCKY14	0.030
Variable length roller lever (3)	Thermoplastic	–	ZCKY415	0.030
	Steel	–	ZCKY43	0.040
For actuation by any moving part				
Square rod (2)	∅ 3 mm steel, L = 125 mm	–	ZCKY51	0.025
Round rod (2)	∅ 3 mm steel, L = 125 mm	–	ZCKY53	0.025
	∅ 3 mm glass fibre, L = 125 mm	–	ZCKY52	0.020

For actuation by specific cam (only for operation with head ZCKE095)

Forked arm with rollers (2)	1 track	–	ZCKY715	0.035
thermoplastic	2 track	–	ZCKY615	0.035

2-pole and double-pole contact blocks

Type of contact	Scheme	For bodies	Positive operation (1)	Reference	Weight kg
NC + NO snap action		ZCKJ1	⊕	XE2SP2151	0.020
NC + NO break before make, slow break		ZCKJ5	⊖	XE2NP2151	0.020
2 CO simultaneous, snap action		ZCKJ25	–	XESP20215	0.045
2 CO staggered, snap action		ZCKJ45	–	XESP20315	0.045
NC + NO make before break, slow break		ZCKJ6	⊖	XE2NP2161	0.020
NC + NC simultaneous, slow break		ZCKJ7	⊖	XE2NP2141	0.020
NO + NO simultaneous, slow break		ZCKJ8	–	XE2NP2131	0.020
NC + NC snap action		ZCKJ9	⊕	XE2SP2141	0.020

(1) ⊕: NC contact with positive opening operation or sub-assembly assuring positive opening operation.

(2) Adjustable throughout 360° in 5° steps, or in 45° steps by reversing the lever or its mounting.

(3) Adjustable throughout 360° in 5° steps.

Limit switches

XC Standard range

Product reference index

D									
DE9RA1012	96	XCKJ161H29	144	XCKN2721P20	106	XCKT2106P16	90	XCMD25F2L1	28
	108	XCKJ167D	148	XCKN2745P20	107	XCKT2110P16	90	XCMD25G1L1	28
DE9RA1212	139	XCKJ167H29	144	XCKN2902P20	106	XCKT2111P16	90	XCMH2102L1	70
DE9RA2012	139	XCKJ50511H29	144	XCKN2903P20	106	XCKT2118P16	91	XCMH2102L2	70
		XCKJ50513H29	144	XCKN2910P20	106	XCKT2121P16	90	XCMH2102L3	70
		XCKJ50541H29	144	XCKN2918P20	107	XCKT2145P16	91	XCMH2102L5	70
X		XCKJ50559H29	144	XCKN2921P20	106	XCMD2101C12	49	XCMH2102L6	70
XCKD2101G11	96	XCKJ561H29	144	XCKN2945P20	107	XCMD2101L1	49	XCMH2102L7	70
XCKD2101P16	96	XCKJ567H29	144	XCKN2949P20	107	XCMD2101M12	49	XCMH2102L8	70
XCKD2102M12	88	XCKL102	118	XCKP2101G11	96	XCMD2102AM4	54	XCMH2102L9	70
XCKD2102P16	84	XCKL106	118	XCKP2101P16	96	XCMD2102C12	36	XCMH2102LA1	70
XCKD2106M12	89	XCKL110	118	XCKP2102M12	82	XCMD2102L1	28	XCMH2103L1	70
XCKD2106P16	85	XCKL115	118	XCKP2102P16	78	XCMD2102M12	36	XCMH2103L2	70
XCKD2110M12	88	XCKL121	118	XCKP2106M12	83	XCMD2106C12	37	XCMH2103L3	70
XCKD2110P16	84	XCKL506	118	XCKP2106P16	79	XCMD2106L1	29	XCMH2103L5	70
XCKD2111M12	88	XCKL515	118	XCKP2110M12	82	XCMD2106M12	37	XCMH2103L8	70
XCKD2111P16	84	XCKL521	118	XCKP2110P16	78	XCMD2110AM4	54	XCMH2106L1	72
XCKD2118M12	89	XCKM102H29	116	XCKP2111M12	82	XCMD2110C12	36	XCMH2106L2	72
XCKD2118P16	85	XCKM106H29	116	XCKP2111P16	78	XCMD2110L1	28	XCMH2107L1	72
XCKD2121M12	88	XCKM110H29	116	XCKP2118M12	83	XCMD2110M12	36	XCMH2107L2	72
XCKD2121P16	84	XCKM115H29	116	XCKP2118P16	79	XCMD2111C12	36	XCMH2107L3	72
XCKD2127M12	88	XCKM121H29	116	XCKP2121M12	82	XCMD2111L1	28	XCMH2110L1	70
XCKD2127P16	84	XCKM502H29	116	XCKP2121P16	78	XCMD2111M12	36	XCMH2110L2	70
XCKD2128M12	88	XCKM506H29	116	XCKP2127M12	82	XCMD2115AM4	54	XCMH2110L3	70
XCKD2128P16	84	XCKM510H29	116	XCKP2127P16	78	XCMD2115C12	37	XCMH2110LA1	70
XCKD2139P16	85	XCKM515H29	116	XCKP2128M12	82	XCMD2115L1	29	XCMH2115L1	71
XCKD2145M12	89	XCKM521H29	116	XCKP2128P16	78	XCMD2115M12	37	XCMH2115L1L0	71
XCKD2145P16	85	XCKML102	120	XCKP2139P16	79	XCMD2116C12	37	XCMH2115L2	71
XCKD2149M12	89	XCKML102H29	120	XCKP2145M12	83	XCMD2116L1	29	XCMH2115L2L0	71
XCKD2149P16	85	XCKML110	120	XCKP2145P16	79	XCMD2116M12	37	XCMH2115L3	71
XCKD21H0P16	85	XCKML110H29	120	XCKP2149M12	83	XCMD2117C12	37	XCMH2115L3L0	71
XCKD21H2M12	89	XCKML115	120	XCKP2149P16	79	XCMD2117L1	29	XCMH2115L8	71
XCKD21H2P16	85	XCKML115H29	120	XCKP21H0P16	79	XCMD2117M12	37	XCMH2115LA1	71
XCKD2502P16	84	XCKML121	120	XCKP21H2P16	79	XCMD2124C12	36	XCMH211AL05	70
XCKD2506P16	85	XCKML121H29	120	XCKP2502P16	78	XCMD2124L1	28	XCMH211AL1	70
XCKD2510P16	84	XCKML502	120	XCKP2510P16	78	XCMD2124M12	36	XCMH2121L1	70
XCKD2511P16	84	XCKML502H29	120	XCKP2511P16	78	XCMD2145C12	37	XCMH2121L1R0	71
XCKD2518P16	85	XCKML515	120	XCKP2518P16	79	XCMD2145L1	29	XCMH2121L2	70
XCKD2521P16	84	XCKN2102P20	106	XCKP2521P16	78	XCMD2145M12	37	XCMH2121L5	70
XCKD2527P16	84	XCKN2103P20	106	XCKP2527P16	78	XCMD21F0C12	36	XCMH2145L1	72
XCKD2528P16	84	XCKN2106P20	107	XCKP2528P16	78	XCMD21F0L1	28	XCMH2145L2	72
XCKD2539P16	85	XCKN2108P20	107	XCKP2539P16	79	XCMD21F0M12	36	XCMH2159L1	72
XCKD2545P16	85	XCKN2110P20	106	XCKP2545P16	79	XCMD21F2C12	36	XCMH2159L2	72
XCKD25H2P16	85	XCKN2118P20	107	XCKS101H29	132	XCMD21F2L1	28	XCMH21F0L1	71
XCKJ10511D	148	XCKN2121P20	106	XCKS102H29	132	XCMD21F2M12	36	XCMH21F0L2	71
XCKJ10511H29	144	XCKN2127P20	106	XCKS131H29	132	XCMD21G1C12	36	XCMH21F2L1	71
XCKJ10513A	150	XCKN2139P20	107	XCKS133H29	132	XCMD21G1L1	28	XCMH21F2L2	71
XCKJ10513D	148	XCKN2145P20	107	XCKS139H29	132	XCMD21G1M12	36	XCMH2902L1	70
XCKJ10513H29	144	XCKN2149P20	107	XCKS141H29	132	XCMD2502AM4	54	XCMH2902L5	70
XCKJ10541A	150	XCKN2502P20	106	XCKS143H29	132	XCMD2502L1	28	XCMH2903L1	70
XCKJ10541D	148	XCKN2503P20	106	XCKS149H29	132	XCMD2506L1	29	XCMH2910L1	70
XCKJ10541H29	144	XCKN2510P20	106	XCKS159H29	132	XCMD2510AM4	54	XCMH2910L2	70
XCKJ10559D	148	XCKN2518P20	107	XCKS501H29	132	XCMD2510L1	28	XCMH2910L3	70
XCKJ10559H29	144	XCKN2521P20	106	XCKS502H29	132	XCMD2511L1	28	XCMV2102D44	53
XCKJ110511H29	146	XCKN2527P20	106	XCKS531H29	132	XCMD2515AM4	54	XCMV2102M12	55
XCKJ110513H29	146	XCKN2545P20	107	XCKS539H29	132	XCMD2515L1	29	XCMV2110D44	53
XCKJ110541H29	146	XCKN2549P20	107	XCKS541H29	132	XCMD2516L1	29	XCMV2110M12	55
XCKJ110559H29	146	XCKN2702P20	106	XCKS543H29	132	XCMD2517L1	29	XCMV2115D44	53
XCKJ1161H29	146	XCKN2710P20	106	XCKS559H29	132	XCMD2545L1	29	XCMV2115M12	55
XCKJ1167H29	146	XCKN2718P20	107	XCKT2102P16	90	XCMD25F0L1	28	XCMV2502D44	53
XCKJ161D	148								

Limit switches

XC Standard range

Product reference index

XCMV2502M12	55	XE2NP2151	97	XZCP1264L10	40	ZCE10	30	ZCEH0	79
XCMV2510D44	53		126		148		38		83
XCMV2510M12	55		139	XZCP1264L2	40		57		85
XCMV2515D44	53		158		148		58		89
XCMV2515M12	55		166		40		60		91
XCMZ06	49		169	XZCP1264L5	148		62	ZCEH2	79
XCMZ07	49	XE2NP2161	97	XZCP1764L10	150		78		83
	96		126	XZCP1764L2	150		82		85
XCNR2102P20	112		139	XZCP1764L5	150		84		89
XCNR2110P20	112		158				88		91
XCNR2118P20	112		166	Z			90	ZCKD01	133
XCNR2121P20	112		169	ZCD21	94	ZCE106	58	ZCKD02	116
XCNR2502P20	112	XE2NP3131	97	ZCD25	94		57		118
XCNR2518P20	112	XE2NP3141	97	ZCD26	94		60		133
XCNR2702P20	112	XE2NP3151	97	ZCD27	94		62	ZCKD06	118
XCNR2710P20	112	XE2NP3161	97		85	ZCE11	30		116
XCNR2721P20	112	XE2SP2141	97	ZCD28	94		38	ZCKD10	118
XCNR2902P20	112		126	ZCD29	94		57		116
XCNR2910P20	112		139	ZCD29M12	88		58	ZCKD15	118
XCNR2918P20	112		158		89		60		116
XCNR2921P20	112		166	ZCD31	94		62	ZCKD21	118
XCNR2927P20	112		169	ZCD35	94		78		116
XCNT2102P16	108	XE2SP2151	97	ZCD37	94		82	ZCKD31	133
XCNT2110P16	108		126	ZCD39	94		84	ZCKD39	133
XCNT2118P16	108		139	ZCDEP16	85		88	ZCKD41	133
XCNT2121P16	108		158	ZCE01	85		90	ZCKD49	133
XCPR2102P20	100		166	ZCE016	57	ZCE21	78	ZCKD59	133
XCPR2110P20	100		169		59		82	ZCKE05	144
XCPR2118P20	100	XE2SP3151	97		61		84	ZCKE055	168
XCPR2119P20	100	XE3NP2141	97		63		88	ZCKE056	165
XCPR2121P20	100		126	ZCE02	30		90	ZCKE065	168
XCPR2127P20	100		158		38	ZCE24	30	ZCKE066	165
XCPR2502P20	100	XE3NP2151	97		57		38	ZCKE085	168
XCPR2510P20	100		126		58		57	ZCKE086	165
XCPR2518P20	100		158		60		58	ZCKE095	168
XCPR2519P20	100	XE3SP2141	97		62		60	ZCKE096	165
XCPR2521P20	100		126		78		62	ZCKE096	165
XCPR2527P20	100		139		82	ZCE27	78	ZCKE215	168
XCPR2902P20	100		158		84		82	ZCKE216	165
XCPR2910P20	100	XE3SP2151	97		88		84	ZCKE235	168
XCPR2918P20	100		126		90		88	ZCKE236	165
XCPR2921P20	100		139	ZCE026	58	ZCE28	78	ZCKE61	144
XCTR2102P16	102		158		57		82	ZCKE615	168
XCTR2110P16	102	XESP2021	158		60		84	ZCKE616	165
XCTR2121P16	102		166		62		88	ZCKE625	168
XCTR2502P16	102	XESP20215	169	ZCE05	49	ZCEF0	30	ZCKE626	165
XCTR2521P16	102	XESP2031	158		96		38	ZCKE635	168
			166	ZCE06	31		57	ZCKE636	165
XE2NP2131	97	XESP20315	169		39		58	ZCKE645	168
	126	XESP3021	139		57		60	ZCKE646	165
	139	XZCP1164L10	40		58		62	ZCKE655	168
	158		148		60	ZCEF2	30	ZCKE656	165
	166		157		62		38	ZCKE665	168
	169	XZCP1164L2	40		79		57	ZCKE667	144
			148		83		58	ZCKE675	168
			157		85		60	ZCKE676	165
XE2NP2141	97	XZCP1164L5	40		89	ZCEG1	30	ZCKJ01	155
	126		148		90		38	ZCKJ0121	159
	139		157				57	ZCKJ02	155
	158	XZCP1169L10	40				58	ZCKJ04	155
	166		40				60		
	169	XZCP1169L2	40				62		
		XZCP1169L5	40						

Limit switches

XC Standard range

Product reference index

ZCKJ1	154	ZCKJ4H29	154	ZCKJD39	154	ZCKY11	144	ZCMD21	46
	164		164	ZCKJD39H29	154		166	ZCMD21AM4	58
	167	ZCKJ4H7	154	ZCKJ39H7	154	ZCKY115	169		59
ZCKJ11	155		164	ZCKL1	124	ZCKY13	144	ZCMD21C12	38
	164	ZCKJ5	154	ZCKL1H7	124	ZCKY14	166		39
			164	ZCKL5	124		169	ZCMD21L08R12	38
ZCKJ1121	156		167	ZCKL5H7	124	ZCKY41	144		39
ZCKJ1121H29	156	ZCKJ521	156	ZCKL6	124		144	ZCMD21L1	47
ZCKJ115	167	ZCKJ521H29	156	ZCKL7	124		144	ZCMD21L2	47
ZCKJ115H29	167	ZCKJ5D	157	ZCKL7H7	124		144	ZCMD21L5	47
ZCKJ11H29	155	ZCKJ5H29	154	ZCKL8	124		166	ZCMD21M12	39
	164		164	ZCKL8H7	124	ZCKY415	169		42
ZCKJ11H7	155		167	ZCKLD31	125	ZCKY43	166		43
	164	ZCKJ5H7	154	ZCKLD31H7	125		169	ZCMD25	46
ZCKJ120	156		164	ZCKLD37	125	ZCKY51	166	ZCMD25AM4	58
ZCKJ121	156		167	ZCKLD39	125		169		59
ZCKJ121H29	156	ZCKJ6	154	ZCKM1	124	ZCKY52	166	ZCMD25L1	47
ZCKJ134	156		164	ZCKM1H29	124		169	ZCMD25L2	47
ZCKJ1D	157		167	ZCKM1H7	124	ZCKY53	166	ZCMD25L5	47
ZCKJ1H29	154	ZCKJ6D	157	ZCKM5	124		169	ZCMD29	46
	164	ZCKJ6H29	154	ZCKM5H29	124	ZCKY59	144	ZCMD29AM4	58
	167		164	ZCKM5H7	124		166		59
ZCKJ1H7	154	ZCKJ6H7	154	ZCKM6	124	ZCKY61	166	ZCMD29C12	38
	164		167	ZCKM6H29	124	ZCKY615	169		39
	167		164	ZCKM7	124	ZCKY71	166	ZCMD29L1	47
ZCKJ2	154	ZCKJ7	154	ZCKM7H29	124	ZCKY715	169	ZCMD29L2	47
	164		164	ZCKM7H7	124	ZCKY81	166		47
ZCKJ21	155		167	ZCKM8	124	ZCKY91	166	ZCMD37	46
	164	ZCKJ7D	157	ZCKM8H29	124	ZCKZ020	159	ZCMD37L1	47
ZCKJ215	167	ZCKJ7H29	154	ZCKM9	124	ZCKZ021	159	ZCMD37L2	47
ZCKJ215H29	167		164	ZCKM9H29	124	ZCKZ034	159	ZCMD37L5	47
ZCKJ215H7	167	ZCKJ7H7	154	ZCKMD31	125	ZCMC21E2	48	ZCMD39	46
ZCKJ21H29	155		164	ZCKMD31H29	125	ZCMC21E3	48	ZCMD39L1	47
	164		167	ZCKMD35	125	ZCMC21E5	48	ZCMD39L2	47
ZCKJ21H7	155	ZCKJ8	154	ZCKMD35H29	125	ZCMC21L1	48	ZCMD39L5	47
	164		164	ZCKMD37	125	ZCMC21L10	48	ZCMD41L1	47
ZCKJ25	167	ZCKJ8D	157	ZCKMD37H29	125	ZCMC21L2	48	ZCMD41L2	47
ZCKJ25H29	167	ZCKJ8H29	154	ZCKMD39	125	ZCMC21L3	48	ZCMD41L5	47
ZCKJ25H7	167		164	ZCKMD39H29	125	ZCMC21L5	48	ZCMD4D	46
ZCKJ2H29	154	ZCKJ8H7	154	ZCKMD39H7	125	ZCMC21L7	48	ZCMD4DL1	47
	164		167	ZCKS1	138	ZCMC21T1	48	ZCMD4DL2	47
ZCKJ2H7	154	ZCKJ9	154	ZCKS1H29	138	ZCMC21T2	48	ZCMD4DL5	47
	164		164	ZCKS2	138	ZCMC21T5	48	ZCMD61	46
ZCKJ4	154		167	ZCKS2H29	138	ZCMC25L1	48	ZCMD61C12	49
	164	ZCKJ902	159	ZCKS404	138	ZCMC25L10	48	ZCMD65	46
ZCKJ404	155	ZCKJ906	159	ZCKS404H29	138	ZCMC25L2	48	ZCMD69C12	49
ZCKJ4045	167	ZCKJ9H29	154	ZCKS5	138	ZCMC25L3	48	ZCMD81L1	47
ZCKJ4045H29	167		164	ZCKS5H29	138	ZCMC25L5	48	ZCMD81L2	47
ZCKJ4045H7	167	ZCKJ906	159	ZCKS6	138	ZCMC25L7	48	ZCMD81L5	47
ZCKJ4046	164	ZCKJ9H29	154	ZCKS6H29	138	ZCMC29L1	48	ZCMV21D44	56
ZCKJ4046H29	164		164	ZCKS7	138	ZCMC29L10	48		59
ZCKJ404H29	155	ZCKJD31	154	ZCKS7H29	138	ZCMC29L2	48	ZCMV21M12	60
ZCKJ404H7	155	ZCKJD31H29	154	ZCKS8	138	ZCMC29L3	48		61
ZCKJ404H7	155	ZCKJD31H7	154	ZCKS8H29	138	ZCMC29L5	48	ZCMV21v	61
ZCKJ41	155	ZCKJD35	154	ZCKS9	138	ZCMC29L7	48	ZCMV25D44	56
	164	ZCKJD35H29	154	ZCKS9H29	138	ZCMC37L5	48		57
ZCKJ4104	155	ZCKJD37	154	ZCKSD31	138	ZCMC39L2	48	ZCMV25M12	60
ZCKJ41046H29	164	ZCKJD37H29	154	ZCKSD31H29	138	ZCMC39L5	48		61
ZCKJ4104H29	155	ZCKJD37H7	154	ZCKSD39	138	ZCMC4DL1	48	ZCMV29D44	56
ZCKJ4104H7	155	ZCKJD37H7	154	ZCKSD39H29	138	ZCMC4DL2	48		57
ZCKJ415	167					ZCMC4DL5	48		
ZCKJ41H29	155								
	164								
ZCKJ45	167								

ZCMV29M12	60	ZCY45	31
	61		39
ZCMV41L03	62		57
	63		58
ZCP21	94		60
ZCP21D44	94		62
ZCP25	94		79
ZCP26	94		83
ZCP27	94		85
ZCP28	94		89
ZCP29	94		91
ZCP29M12	82	ZCY49	79
	83		83
ZCP31	94		85
ZCP37	94		89
ZCP39	94		
ZCPED44	94		
ZCPEP16	78		
	79		
ZCT21G11	95		
ZCT21N12	95		
ZCT21P16	95		
ZCT25G11	95		
ZCT25N12	95		
ZCT25P16	95		
ZCT26G11	95		
ZCT26P16	95		
ZCT27G11	95		
ZCT27N12	95		
ZCT27P16	95		
ZCT28G11	95		
ZCT28N12	95		
ZCT28P16	95		
ZCY15	31		
	39		
	57		
	58		
	60		
	62		
ZCY16	31		
	39		
	57		
	58		
	60		
	62		
ZCY17	31		
	39		
	57		
	58		
	60		
	62		
ZCY18	85		
	89		
	79		
	83		
	91		
ZCY39	85		
	89		
	79		
	83		
	91		

По вопросам продаж и поддержки обращайтесь:

Алматы (727)345-47-04
Ангарск (3955)60-70-56
Архангельск (8182)63-90-72
Астрахань (8512)99-46-04
Барнаул (3852)73-04-60
Белгород (4722)40-23-64
Благовещенск (4162)22-76-07
Брянск (4832)59-03-52
Владивосток (423)249-28-31
Владикавказ (8672)28-90-48
Владимир (4922)49-43-18
Волгоград (844)278-03-48
Вологда (8172)26-41-59
Воронеж (473)204-51-73
Екатеринбург (343)384-55-89

Иваново (4932)77-34-06
Ижевск (3412)26-03-58
Иркутск (395)279-98-46
Казань (843)206-01-48
Калининград (4012)72-03-81
Калуга (4842)92-23-67
Кемерово (3842)65-04-62
Киров (8332)68-02-04
Коломна (4966)23-41-49
Кострома (4942)77-07-48
Краснодар (861)203-40-90
Красноярск (391)204-63-61
Курск (4712)77-13-04
Курган (3522)50-90-47
Липецк (4742)52-20-81

Магнитогорск (3519)55-03-13
Москва (495)268-04-70
Мурманск (8152)59-64-93
Набережные Челны (8552)20-53-41
Новокузнецк (3843)20-46-81
Ноябрьск (3496)41-32-12
Новосибирск (383)227-86-73
Омск (3812)21-46-40
Орел (4862)44-53-42
Оренбург (3532)37-68-04
Пенза (8412)22-31-16
Петрозаводск (8142)55-98-37
Псков (8112)59-10-37
Пермь (342)205-81-47

Ростов-на-Дону (863)308-18-15
Рязань (4912)46-61-64
Самара (846)206-03-16
Санкт-Петербург (812)309-46-40
Саратов (845)249-38-78
Севастополь (8692)22-31-93
Саранск (8342)22-96-24
Симферополь (3652)67-13-56
Смоленск (4812)29-41-54
Сочи (862)225-72-31
Ставрополь (8652)20-65-13
Сургут (3462)77-98-35
Сыктывкар (8212)25-95-17
Тамбов (4752)50-40-97
Тверь (4822)63-31-35

Тольятти (8482)63-91-07
Томск (3822)98-41-53
Тула (4872)33-79-87
Тюмень (3452)66-21-18
Ульяновск (8422)24-23-59
Улан-Удэ (3012)59-97-51
Уфа (347)229-48-12
Хабаровск (4212)92-98-04
Чебоксары (8352)28-53-07
Челябинск (351)202-03-61
Череповец (8202)49-02-64
Чита (3022)38-34-83
Якутск (4112)23-90-97
Ярославль (4852)69-52-93

Россия +7(495)268-04-70

Казахстан +(727)345-47-04

Беларусь +(375)257-127-884

Узбекистан +998(71)205-18-59

Киргизия +996(312)96-26-47

эл.почта: tuq@nt-rt.ru || сайт: <https://telemecanique.nt-rt.ru>