

Концевые выключатели ХСЕ, ХСЈ

Технические характеристики

По вопросам продаж и поддержки обращайтесь:

Алматы (727)345-47-04
Ангарск (3955)60-70-56
Архангельск (8182)63-90-72
Астрахань (8512)99-46-04
Барнаул (3852)73-04-60
Белгород (4722)40-23-64
Благовещенск (4162)22-76-07
Брянск (4832)59-03-52
Владивосток (423)249-28-31
Владикавказ (8672)28-90-48
Владимир (4922)49-43-18
Волгоград (844)278-03-48
Вологда (8172)26-41-59
Воронеж (473)204-51-73
Екатеринбург (343)384-55-89

Иваново (4932)77-34-06
Ижевск (3412)26-03-58
Иркутск (395)279-98-46
Казань (843)206-01-48
Калининград (4012)72-03-81
Калуга (4842)92-23-67
Кемерово (3842)65-04-62
Киров (8332)68-02-04
Коломна (4966)23-41-49
Кострома (4942)77-07-48
Краснодар (861)203-40-90
Красноярск (391)204-63-61
Курск (4712)77-13-04
Курган (3522)50-90-47
Липецк (4742)52-20-81

Магнитогорск (3519)55-03-13
Москва (495)268-04-70
Мурманск (8152)59-64-93
Набережные Челны (8552)20-53-41
Нижний Новгород (831)429-08-12
Новокузнецк (3843)20-46-81
Ноябрьск (3496)41-32-12
Новосибирск (383)227-86-73
Омск (3812)21-46-40
Орел (4862)44-53-42
Оренбург (3532)37-68-04
Пенза (8412)22-31-16
Петрозаводск (8142)55-98-37
Псков (8112)59-10-37
Пермь (342)205-81-47

Ростов-на-Дону (863)308-18-15
Рязань (4912)46-61-64
Самара (846)206-03-16
Санкт-Петербург (812)309-46-40
Саратов (845)249-38-78
Севастополь (8692)22-31-93
Саранск (8342)22-96-24
Симферополь (3652)67-13-56
Смоленск (4812)29-41-54
Сочи (862)225-72-31
Ставрополь (8652)20-65-13
Сургут (3462)77-98-35
Сыктывкар (8212)25-95-17
Тамбов (4752)50-40-97
Тверь (4822)63-31-35

Тольятти (8482)63-91-07
Томск (3822)98-41-53
Тула (4872)33-79-87
Тюмень (3452)66-21-18
Ульяновск (8422)24-23-59
Улан-Удэ (3012)59-97-51
Уфа (347)229-48-12
Хабаровск (4212)92-98-04
Чебоксары (8352)28-53-07
Челябинск (351)202-03-61
Череповец (8202)49-02-64
Чита (3022)38-34-83
Якутск (4112)23-90-97
Ярославль (4852)69-52-93

Россия +7(495)268-04-70

Казахстан +(727)345-47-04

Беларусь +(375)257-127-884

Узбекистан +998(71)205-18-59

Киргизия +996(312)96-26-47

эл.почта: tuq@nt-rt.ru || сайт: <https://telemecanique.nt-rt.ru>

Limit switches XCE and XCJ ranges

- **General**
 - General page 2
 - Applications examples page 2
 - Contact blocks operation page 3
 - Utilization categories IEC 60947-5-1 page 4
 - Setting up and mounting advice page 5
 - European standards page 6
 - American standards page 7
 - Operating heads selection page 8
 - Limit switches selection guide page 9

- **XCE limit switches for medium duty applications**
 - Presentation and general characteristics page 10
 - References and complementary characteristics pages 11 to 13
 - Operating diagrams pages 11 to 13
 - Dimensions pages 11, 14 and 15

- **XCJ limit switches for light to medium duty applications**
 - Presentation and general characteristics page 16
 - References and complementary characteristics pages 17 and 18
 - Operating diagrams pages 17 and 18
 - Dimensions pages 17 and 19

- **Product reference index** page 20

Limit switches

XC range

General

Electromechanical detection

Limit switches are used in all automated installations and also in a wide variety of applications, due to the numerous advantages inherent to their technology. They transmit data to the logic processing system regarding:

- presence/absence,
- passage,
- positioning,
- end of travel.

Simple to install switches, offering many advantages

■ From an electrical viewpoint:

- galvanic separation of circuits,
- models suitable for low power switching, combined with good electrical durability,
- very good short-circuit withstand in coordination with appropriate fuses,
- total immunity to electromagnetic interference,
- high rated operational voltage.

■ From a mechanical viewpoint:

- N/C contacts with positive opening operation,
- high resistance to the different ambient conditions encountered in industry,
- high repeat accuracy, up to 0.01 mm on the tripping points,
- simple visible operation.

Mechanical endurance

■ Major factors affecting the mechanical endurance of a limit switch:

- operating speed and frequency,
- operating travel (percentage of total travel),
- cam angle,
- environment (presence of abrasive dust, corrosive substances, etc).

Applications examples

Roller plunger

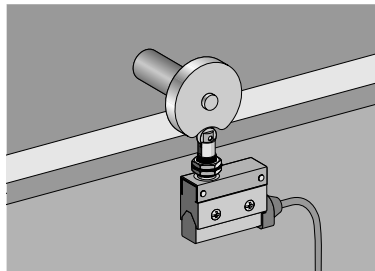

End plunger

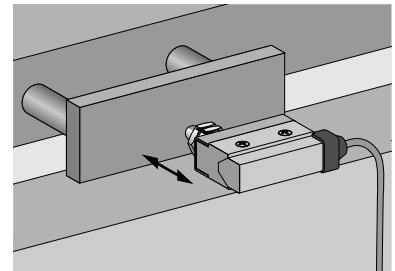

Rotary style head

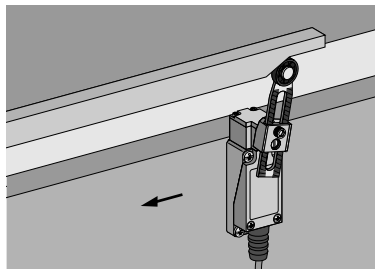

Multidirectional head

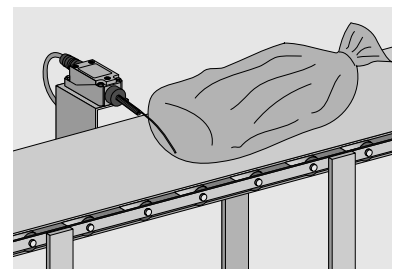

Contact blocks operation

Example : 1 N/C + 1 N/O

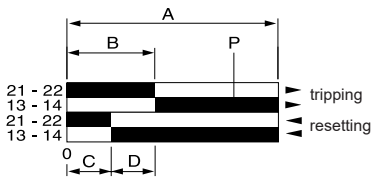

Linear movement (plunger)

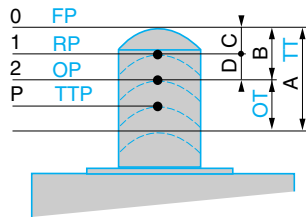

Rotary movement

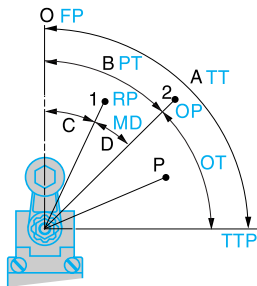

Example : 1 N/C + 1 N/O break before make

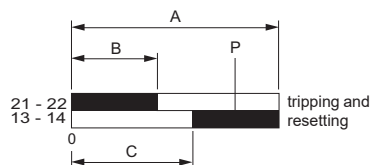

Linear movement (plunger)

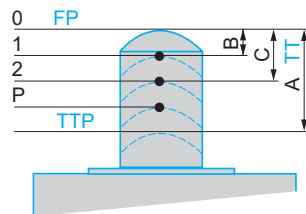

Rotary movement

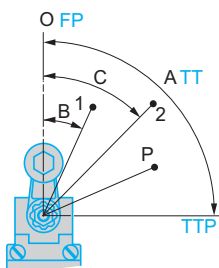

Snap action contacts

Linear movement (plunger)

European terminology	Terminology according to JIS C 4508
A Maximum travel	TT Total travel
B Tripping travel	–
C Resetting travel	–
D Differential travel	–
P Point from which positive opening is assured	–
A-B No specific term	OT Over Travel
1 Resetting point	RP Release Position
2 Tripping point	OP Operation Position
0 No specific term	FP Free Position
– No specific term	TTP Total Travel Position

Rotary movement

European terminology	Terminology according to JIS C 4508
A Maximum travel	TT Total travel
B Tripping travel	PT Pre-Travel
C Resetting travel	–
D Differential travel	MD Movement Differential
P Point from which positive opening is assured	–
A-B No specific term	OT Over Travel
1 Resetting point	RP Release Position
2 Tripping point	OP Operation Position
0 No specific term	FP Free Position
– No specific term	TTP Total Travel Position

Slow break contacts

Linear movement (plunger)

European terminology	Terminology according to JIS C 4508
A Maximum travel	TT Total travel
B Tripping and Resetting travel of N/C contact	–
C Tripping and Resetting travel of N/O contact	–
P Point from which positive opening is assured	–
1 Tripping and Resetting point of N/C contact	–
2 Tripping and Resetting point of N/O contact	–
0 No specific term	FP Free Position
– No specific term	TTP Total Travel Position

Rotary movement

European terminology	Terminology according to JIS C 4508
A Maximum travel	TT Total travel
B Tripping and Resetting travel of N/C contact	–
C Tripping and Resetting travel of N/O contact	–
P Point from which positive opening is assured	–
1 Tripping and Resetting point of N/C contact	–
2 Tripping and Resetting point of N/O contact	–
0 No specific term	FP Free Position
– No specific term	TTP Total Travel Position

Limit switches

XC range

Contact ratings

Utilization categories IEC 60947-5-1

Kind of current	Category	Typical application	$T_{0.95}$ (DC) (1) COS φ (AC)
Alternating current	AC-12	Control of resistive loads and solid state loads with isolation by opto couplers	0.9
	AC-13	Control of solid state loads with transformer isolation	0.65
	AC-14	Control of small electromagnetic loads (≤ 72 VA)	0.3
	AC-15	Control of electromagnetic loads (> 72 VA)	0.3
Direct current	DC-12	Control of resistive loads and solid state loads with isolation by opto couplers	1 ms
	DC-13	Control of electromagnets	300 ms maximum
	DC-14	Control of electromagnetic loads having economy resistors in circuit	15 ms

(1) $T_{0.95}$ = time to reach 95 % of the steady state current.

Contact rating designation IEC 60947-5-1

Designation	Utilization category	Conventional therm. current	Rated operational current I_e at rated operating voltage U_e					
			120 V	240 V	380 V	480 V	500 V	600 V
A150	AC-15	10 A	6 A	–	–	–	–	–
A300	AC-15	10 A	6 A	3 A	–	–	–	–
A600	AC-15	10 A	6 A	3 A	1.9 A	1.5 A	1.4 A	1.2 A
B150	AC-15	5 A	3 A	–	–	–	–	–
B300	AC-15	5 A	3 A	1.5 A	–	–	–	–
B600	AC-15	5 A	3 A	1.5 A	0.95 A	0.75 A	0.72 A	0.6 A
C150	AC-15	2.5 A	1.5 A	–	–	–	–	–
C300	AC-15	2.5 A	1.5 A	0.75 A	–	–	–	–
C600	AC-15	2.5 A	1.5 A	0.75 A	0.47 A	0.375 A	0.35 A	0.3 A
D150	AC-14	1.0 A	0.6 A	–	–	–	–	–
D300	AC-14	1.0 A	0.6 A	0.3 A	–	–	–	–
E150	AC-14	0.5 A	0.3 A	–	–	–	–	–

Designation	Utilization category	Conventional therm. current	Rated operational current I_e at rated operating voltage U_e				
			125 V	250 V	440 V	500 V	600 V
N150	DC-13	10 A	2.2 A	–	–	–	–
N300	DC-13	10 A	2.2 A	1.1 A	–	–	–
N600	DC-13	10 A	2.2 A	1.1 A	0.63 A	0.55 A	0.4 A
P150	DC-13	5 A	1.1 A	–	–	–	–
P300	DC-13	5 A	1.1 A	0.55 A	–	–	–
P600	DC-13	5 A	1.1 A	0.55 A	0.31 A	0.27 A	0.2 A
Q150	DC-13	2.5 A	0.55 A	–	–	–	–
Q300	DC-13	2.5 A	0.55 A	0.27 A	–	–	–
Q600	DC-13	2.5 A	0.55 A	0.27 A	0.15 A	0.13 A	0.1 A
R150	DC-13	1.0 A	0.22 A	–	–	–	–
R300	DC-13	1.0 A	0.22 A	0.1 A	–	–	–

Limit switches

XC range

Setting up and mounting advice

Setting up

Reverse mounting of the operating lever (for limit switches XCE)

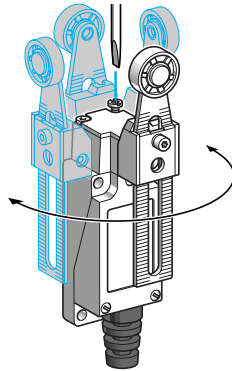

Mounting advice

Sweep of connecting cable

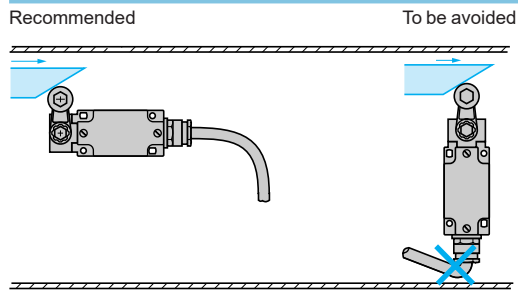

Position of cable-gland

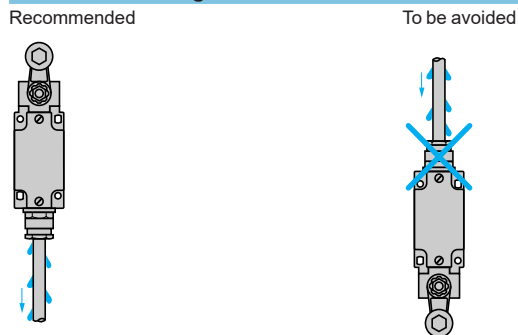

Type of cam

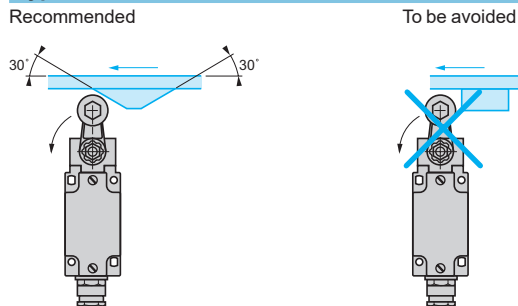

Mounting and fixing of limit switches

XCJ110C, XCJ102C and XCJ103C



Limit switches

XC range

Degrees of protection provided by enclosures



European standards

Degrees of protection against the penetration of solid bodies, water and personnel access to live parts

The European standard EN 60529 dated October 1991, IEC publication 529 (2nd edition - November 1989), defines a coding system (IP code) for indicating the degree of protection provided by electrical equipment enclosures against accidental direct contact with live parts and against the ingress of solid foreign objects or water. This standard does not apply to protection against the risk of explosion or conditions such as humidity, corrosive gasses, fungi or vermin.

IP●● code

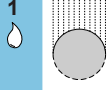
- The IP code comprises 2 characteristic numerals (e.g. IP 55)
- Any characteristic numeral which is unspecified is replaced by an X (e.g. IP XX)

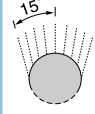
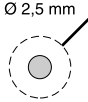
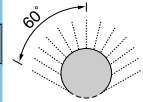
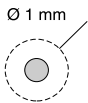
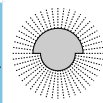
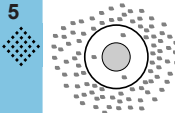
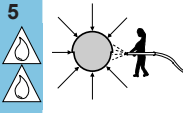
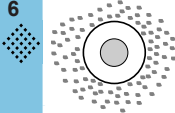
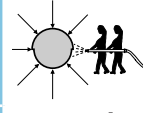
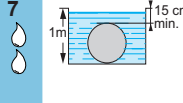
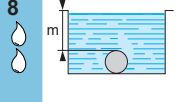
1 st characteristic numeral: corresponds to protection of the equipment against penetration of solid objects and protection of personnel against direct contact with live parts.		2 nd characteristic numeral: corresponds to protection of the equipment against penetration of water with harmful effects.	
	Protection of the equipment	Protection of personnel	
0	Non-protected	Non-protected	0 Non-protected
1	Ø 50 mm  Protected against the penetration of solid objects having a diameter greater than or equal to 50 mm.	Protected against direct contact with the back of the hand (accidental contacts).	1  Protected against vertical dripping water, (condensation)
2	Ø 12,5 mm  Protected against the penetration of solid objects having a diameter greater than or equal to 12.5 mm.	Protected against direct finger contact.	2  Protected against dripping water at an angle of up to 15°.
3	Ø 2,5 mm  Protected against the penetration of solid objects having a diameter greater than or equal to 2.5 mm.	Protected against direct contact with a Ø 2.5 mm tool.	3  Protected against rain at an angle of up to 60°.
4	Ø 1 mm  Protected against the penetration of solid objects having a diameter > 1 mm.	Protected against direct contact with a Ø 1 mm wire.	4  Protected against splashing water in all directions.
5	 Dust protected (no harmful deposits).	Protected against direct contact with a Ø 1 mm wire.	5  Protected against water jets in all directions.
6	 Dust tight.	Protected against direct contact with a Ø 1 mm wire.	6  Protected against powerful jets of water and waves.
			7  Protected against the effects of temporary immersion.
			8  Protected against the effects of prolonged immersion under specified conditions.

Limit switches

XC range

Degrees of protection provided by enclosures

American standards

Standard UL 50 - Table 6.1 - Enclosures types, defines a coding system for indicating the protection provided by electrical equipment enclosures against the ingress of solid foreign objects and fluids.

Type	Intended use and description
1	Indoor use primarily to provide a degree of protection against limited amounts of falling dirt.
2	Indoor use primarily to provide a degree of protection against limited amounts of falling water and dirt.
3	Outdoor use primarily to provide a degree of protection against rain, sleet, wind blown dust and damage from external ice formation.
3R	Outdoor use primarily to provide a degree of protection against rain, sleet, and damage from external ice formation.
3S	Outdoor use primarily to provide a degree of protection against rain, sleet, wind blown dust and provide for operation of external mechanisms when ice laden.
4	Indoor or outdoor use primarily to provide a degree of protection against rain, sleet, wind blown dust and provide for operation of external mechanisms when ice laden.
4X	Indoor or outdoor use primarily to provide a degree of protection against corrosion, wind blown dust and rain, splashing water, hose-directed water, and damage from external ice formation.
5	Indoor use primarily to provide a degree of protection against settling airborne dust, falling dirt, and dripping noncorrosive liquids.
6	Indoor or outdoor use primarily to provide a degree of protection against hose-directed water, and the entry of water during occasional temporary submersion at a limited depth and damage from external ice formation.
6P	Indoor or outdoor use primarily to provide a degree of protection against hose-directed water, the entry of water during prolonged submersion at a limited depth and damage from external ice formation.
12, 12K	Indoor use primarily to provide a degree of protection against limited circulation dust, falling dirt, and dripping noncorrosive liquids.
13	Indoor use primarily to provide a degree of protection against dust, spraying of water, oil and noncorrosive coolant.















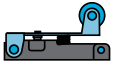

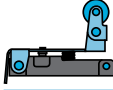

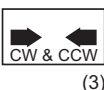

Limit switches

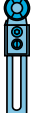
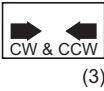
XC range

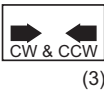
Operating heads

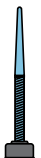
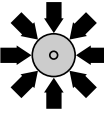
Operating heads selection

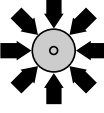
5 points to consider...

	Direction of operation	Operating speed (1)	Positivity (2)	Risk of overtravel damage	Target type
Plunger style					
	↓	0.5 m/s	Yes	Very high	
	↔	0.85 m/s	Yes	High	
Lever and roller lever plunger style					
	→	0.85 m/s	Yes	Medium	
	→	0.85 m/s	Yes	Medium	
	→ or ↓	0.5 m/s	No	High	
Rotary style					
		1 m/s	Yes (with non flexible levers only)	Low	
		1 m/s	Yes (with non flexible levers only)	Low	
		1 m/s	Yes (with non flexible levers only)	Low	
Multidirectional style					
		0.5...1 m/s	No	Lowest	
		0.5...1 m/s	No	Lowest	

(1) These values are indicative only. For precise information relating to a particular device, refer to the appropriate technical characteristics.
 (2) Only when combined with a positive opening contact.
 (3) CW = clockwise, CCW = counter clockwise.

Applications

Medium duty:
small compactors, wood working, metal working, food processing...

Light duty:
injection moulding, assembly, metal working, packaging...



Enclosure (body)	
Conforming to standards	
Conformities	
Body dimensions in mm (w x h x d)	
Head	
Contact blocks	1 C/O snap action - Form C 1 NO + 1NC snap action - Form Za
Degree of protection	
Cabling	Screw terminal Pre-cabled Connector
Type references	
Pages	

Zinc alloy (cover: plastic)
IEC 60947-5-1
CE, CCC
28 x 64 x 25
Linear, rotary or multi-directional
–
•
IP 65
Flexible rubber cable gland suitable for cable Ø 6...9 mm
–
–
XCE
10 to 15

Plastic (cover: zinc alloy)
IEC 60947-5-1
CE, CCC
54 x 42 x 21
Linear
•
–
IP 40, IK 04
Flexible rubber cable gland suitable for cable Ø 8.5...10.5 mm
–
–
XCJ
16 to 19

Limit switches

XC range

For medium duty applications, XCE

XCE (1 NO + 1 NC form Za)

With head for linear movement (plunger) operators

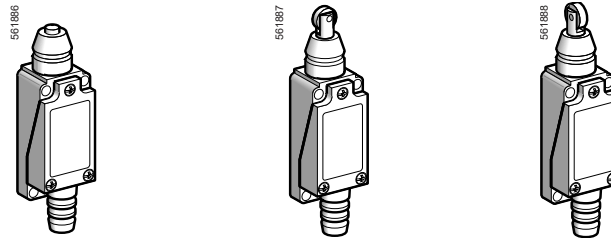

Page 11

With head for rotary movement (lever) operators

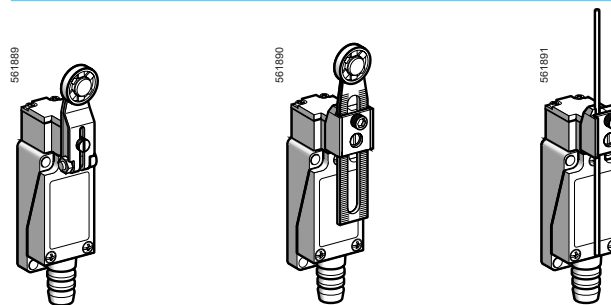

Page 12

With head for multi-directional operators

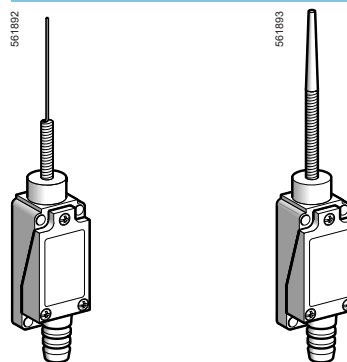

Page 13

Environment

Conforming to standards	IEC 60947-5-1
Certifications	CE, CCC
Ambient air temperature	For operation : - 25...+ 70 °C, for storage: -40...+ 70 °C
Vibration resistance	Conforming to IEC 60068-2-6 10...55 Hz, 3 mm double amplitude
Shock resistance	Conforming to IEC 60068-2-27 30 gn, 11 ms, in the free position
Degree of protection	Conforming to IEC 60529 IP 65
Materials	Body and head: metal, cover: plastic
Mechanical durability	10 x 10⁵ operations
Cable entry	Flexible rubber cable gland suitable for cable Ø 6...9 mm
Tightening torques	Body (M4 screws) 2.4...3.0 N.m / 21.24...26.55 lb-in
	Cover 0.5...0.6 N.m / 4.42...5.31 lb-in
	Head (rotary type) 0.3...0.4 N.m / 2.65...3.54 lb-in
	Roller lever (rotary type) 2.4...3.0 N.m / 21.24...26.55 lb-in



Contact block characteristics

Rated operational characteristics	~ AC (Ue = 240 V, Ie = 3 A, Ith = 10 A); --- DC (Ue = 220 V, Ie = 0.3 A)
Rated insulation voltage	Ui=300V, pollution degree 3 complies with IEC 60947
Insulation resistance	> 100 mΩ at 500 V
Operating frequency	120 operations per minute
Electrical endurance	8 x 10 ⁵ operations
Contact resistance	≤ 25 mΩ
Cabling	Screw terminals, torque range 0.6...1.1 N.m / 5.31...8.85 lb-in Maximum clamping capacity 0.75...1.5 mm ² per terminal

Limit switches

XC range

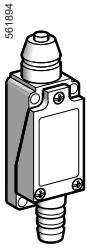
For medium duty applications, XCE

Type of operating head			
Plunger			
			
Type of operator	Steel end plunger	Steel roller plunger for lateral cam movement	Steel roller plunger for traverse cam movement

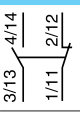
References (1)			
1 NO + 1 NC (form Za)		XCE110C	XCE102C
Weight (kg)		0.110	0.126

(1) All products are supplied in individual packaging. They are also available in a bulk pack of 10 products. To order the bulk packed versions, add the suffix **TQ** at the end of product reference. Example **XCE110CTQ**. Obviously the indivisible order quantity for this version is 10.

Complementary characteristics not shown under general characteristics (page 10)	
Switch actuation	On end
Operating force (maxi.)	9 N
Release force (mini.)	1.5 N
Operating frequency	120 operations per minute
Maximum actuation speed	0.5 m/s
Minimum actuation speed	5 mm/s
Mechanical durability	10 x 10 ⁶ operations (For XCE102C and XCE103C, actuation by 30° cam: 1 million operations)
Cabling	Flexible rubber cable gland suitable for cable Ø 6...9 mm

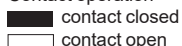
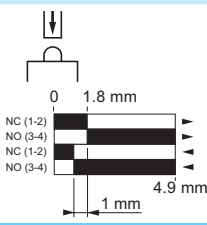
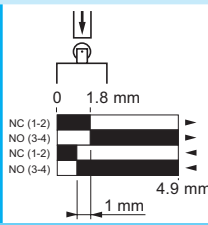
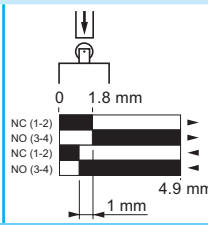
Operating diagrams			
Type of actuation			
Operating diagrams			
Contact operation			
			
			

Dimensions in mm

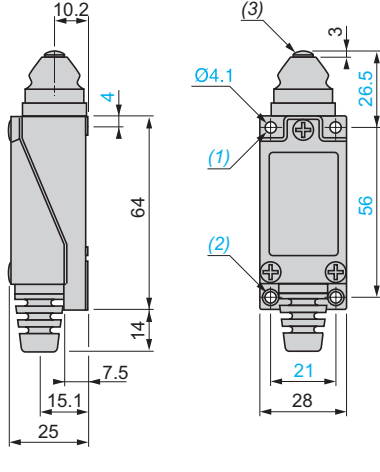
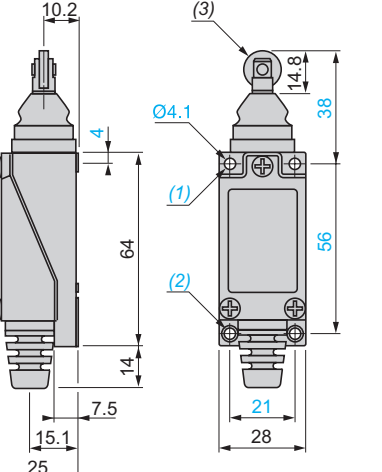
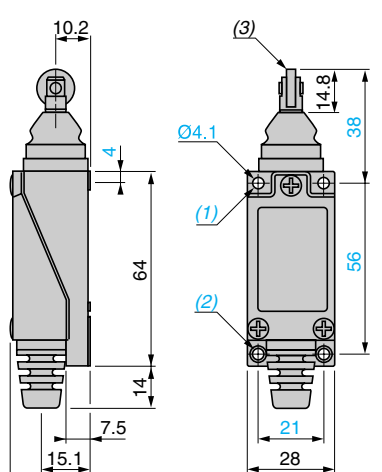
XCE110C	XCE102C	XCE103C
		

- (1) 2 holes M5 tapped 7 in depth.
 - (2) 2 M5 tapped holes.
 - (3) Stainless steel plunger Ø 7.
- (1) 2 holes M5 tapped 7 in depth.
 - (2) 2 M5 tapped holes.
 - (3) Stainless steel roller Ø 12.5 x 3.8.
- (1) 2 holes M5 tapped 7 in depth.
 - (2) 2 M5 tapped holes.
 - (3) Stainless steel roller Ø 12.5 x 3.8.

Limit switches

XC range

For medium duty applications, XCE

Type of operating head

Rotary

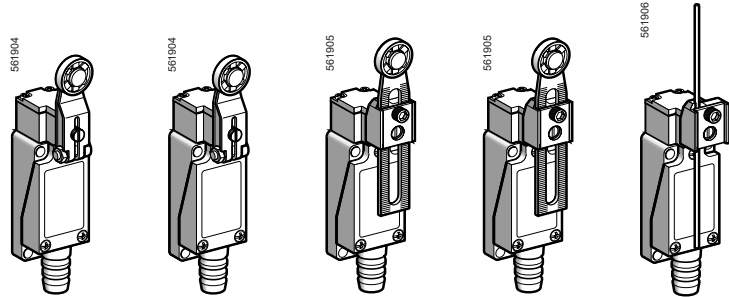

Type of operator	Thermoplastic roller lever	Steel roller lever	Variable length thermoplastic roller lever	Variable length steel roller lever	Round rod Ø 3 mm steel rod
------------------	----------------------------	--------------------	--	------------------------------------	----------------------------

References (1)

1 NO + 1 NC (form Za)		XCE118C	XCE119C	XCE145C	XCE146C	XCE154C
Weight (kg)		0.152	0.159	0.175	0.181	0.164



Complementary characteristics not shown under general characteristics (page 10)

Switch actuation	By 30° cam	By any moving part
Operating force (maxi.)	7.5 N	
Release force (mini.)	0.5 N	
Operating frequency	120 operations per minute	
Maximum actuation speed	1 m/s	
Minimum actuation speed	9 mm/s for rotary type 5 mm/s for multi-directional type	
Mechanical durability	10 x 10 ⁶ operations	
Cabling	Flexible rubber cable gland suitable for cable Ø 6...9 mm Maximum clamping capacity 0.75...1.5 mm ² per terminal	

Operating diagrams

Type of actuation

Operating diagrams

Contact operation
 contact closed
 contact open

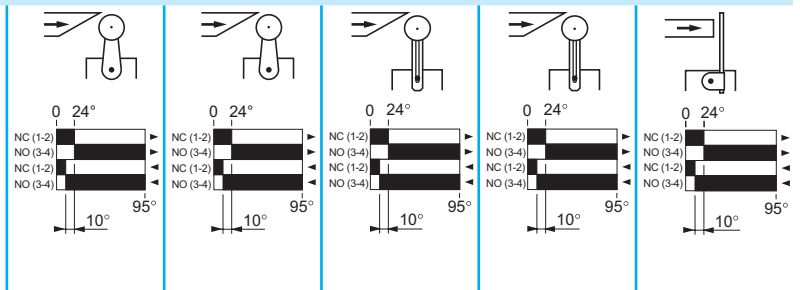

(1) All products are supplied in individual packaging. They are also available in a bulk pack of 10 products. To order the bulk packed versions, add the suffix **TQ** at the end of product reference. Example **XCE118CTQ**. Obviously the indivisible order quantity for this version is 10.

Limit switches

XC range

For medium duty applications, XCE

Type of operating head
Multi-directional

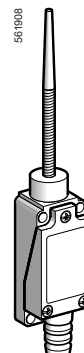
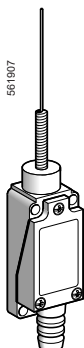

Type of operator

"Cat's whisker"

Spring rod lever with thermoplastic end

References (1)

1 NO + 1 NC
(form Za)



XCE106C

XCE181C

Weight (kg)

0.109

0.108

Complementary characteristics not shown under general characteristics (page 10)

Switch actuation

By any moving part

Operating force (maxi.)

1.5 N

Release force (mini.)

0.04 N

Operating frequency

120 operations per minute

Maximum actuation speed

1 m/s

Mechanical durability

4 x 10⁶ operations

Cabling

Flexible rubber cable gland suitable for cable Ø 6...9 mm
Maximum clamping capacity 1.5 mm² per terminal

Operating diagrams

Type of actuation

Operating diagrams

Contact operation

■ contact closed

□ contact open

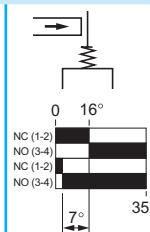
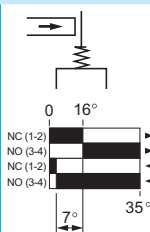

(1) All products are supplied in individual packaging. They are also available in a bulk pack of 10 products. To order the bulk packed versions, add the suffix **TQ** at the end of product reference. Example **XCE181CTQ**. Obviously the indivisible order quantity for this version is 10.

Limit switches

XC range

For medium duty applications, XCE

Dimensions in mm

XCE118C, XCE119C

XCE145C, XCE146C

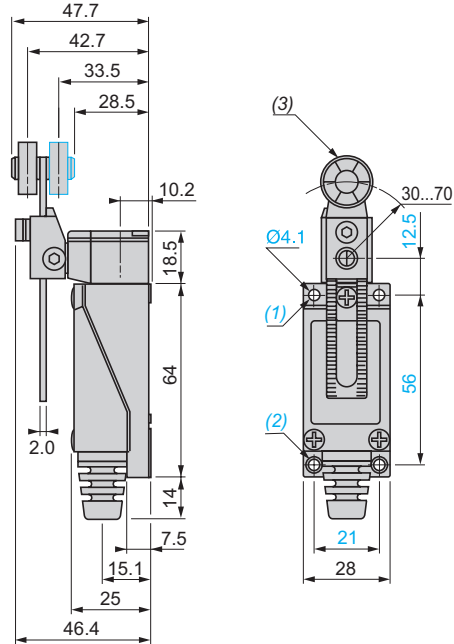
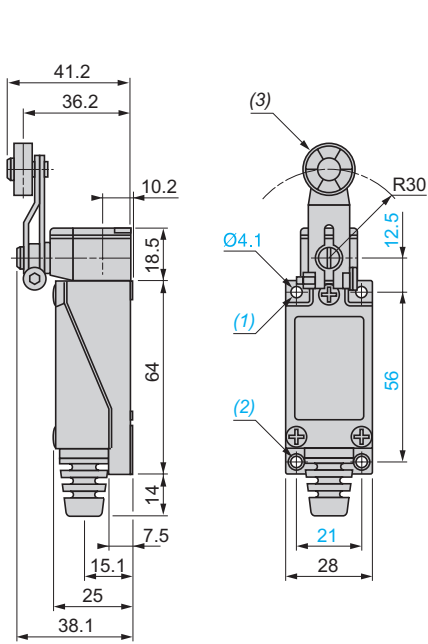

- (1) 2 holes M5 tapped 7 in depth.
- (2) 2 M5 tapped holes.
- (3) Nylon and metal roller Ø 18 x 7 (roller can be rotated and locked in any position through 360°).

- (1) 2 holes M5 tapped 7 in depth.
- (2) 2 M5 tapped holes.
- (3) Nylon and metal roller Ø 18 x 7.

XCE154C

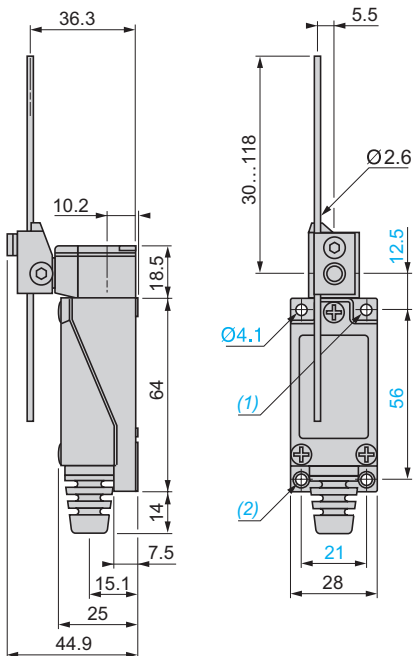

- (1) 2 holes M5 tapped 7 in depth.
- (2) 2 M5 tapped holes.

Dimensions in mm

XCE106C

XCE181C

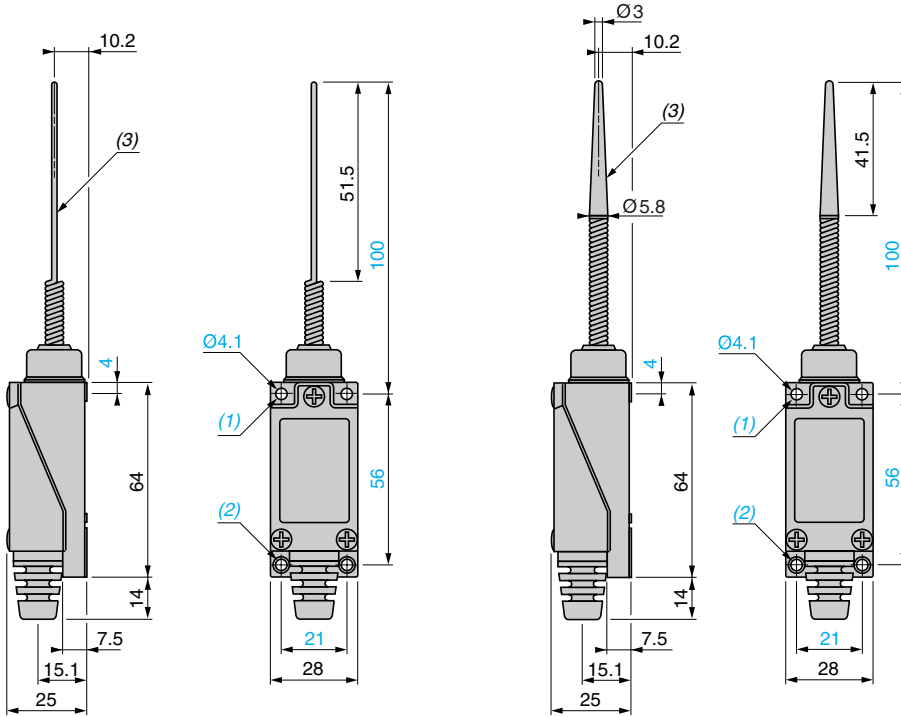

- (1) 2 holes M5 tapped 7 in depth.
- (2) 2 M5 tapped holes.
- (3) Stainless steel wire Ø 1.2.

- (1) 2 holes M5 tapped 7 in depth.
- (2) 2 M5 tapped holes.
- (3) Nylon rod.

Limit switches

XC range

For light to medium duty applications, XCJ

XCJ (single-pole contact 1 C/O form C)

With head for linear movement (plunger) operators, fixing by head or body

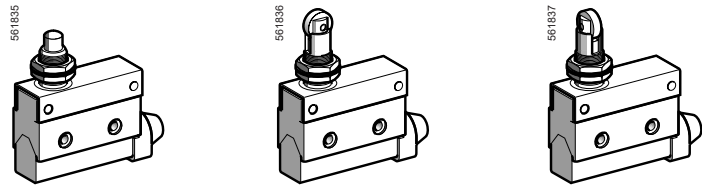

Page 17

With head for linear movement (lever plunger) operators, fixing by body

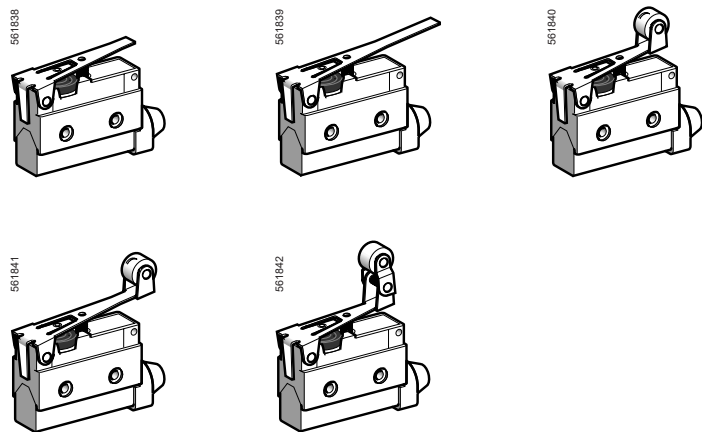

Page 18

Environnement

Conforming to standards	IEC 60947-5-1
Certifications	CE, CCC
Ambient air temperature	For operation: -25...+70 °C, for storage: -40...+70 °C
Vibration resistance	Conforming to IEC 60068-2-6 10...55 Hz XCJ110, XCJ102 and XCJ103C: 3.0 mm double amplitude XCJ125, XCJ126 and XCJ127C: 1.5 mm double amplitude XCJ121 and XCJ128C: 0.7 mm double amplitude
Shock resistance	Conforming to IEC 60068-2-27 10 gn, 11 ms, in the free position
Degree of protection	Conforming to IEC 60529 IP 40 IK 04
Materials	Body: plastic, head: metal
Mechanical durability	10 x 10⁶ operations
Cable entry	Flexible rubber cable gland suitable for cable Ø 8.5...10.5 mm
Head mounting	Torque range for XCE110C, XCJ102C and XCJ103C: 2.9...4.9 N.m / 25.66...43.66 lb-in
Body mounting	Mounting torque range (M4 screws): 1.2...1.5 N.m / 10.62...13.27 N.m



Contact block characteristics

Rated operational characteristics	~ AC (U _e = 240 V, I _e = 10 A), I _{th} = 10 A --- DC (U _e = 220 V, I _e = 0.3 A)
Insulation resistance	> 100 mΩ at --- 500 V
Dielectric withstand voltage	~ 1000 V, 50/60 Hz for 1 minute between non-continuous terminals ~ 2000 V, 50/60 Hz between current carrying and non-current carrying parts and between each terminal and ground. Double isolation, CE Class II conforming to IEC 60947-5-1
Operating frequency	120 operations per minute
Electrical endurance	> 8 x 10 ⁵ operations (~ 220 V, 10 A, P.F. = 1)
Contact resistance	≤ 25 mΩ
Cabling	M3.5 screw terminals (use cable lug with flexible cable) Torque range: 0.8...1.2 N.m / 7.08...10.62 lb-in

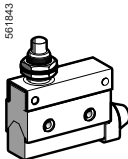
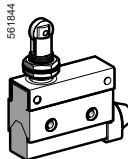
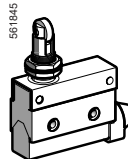

Limit switches

XC range

For light to medium duty applications, XCJ

Type of operating head			
	Plunger (fixing by head or body)		
			
Type of operator	Steel end plunger	Steel roller plunger for lateral cam movement	Steel roller plunger for traverse cam movement
References			
Single pole 1 C/O (form C)		XCJ110C	XCJ102C
Weight (kg)		0.081	0.086
			0.088
Complementary characteristics not shown under general characteristics (page 16)			
Switch actuation	On end		
Operating force (max.)	4 N		
Release force (min.)	0.98 N		
Operating frequency	120 operations per minute		
Actuation speed	0.01 mm/s...50 cm/s (at pin plunger)		
Mechanical durability	10 x 10 ⁶ operations (for XCJ102C and XCJ103C, actuation by 30° cam: 4 million operations)		
Cabling	M3.5 screw terminals (use cable lug with flexible cable) Torque range: 0.8...1.2 N.m / 7.08...10.62 lb-in		

Operating diagrams

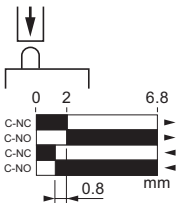
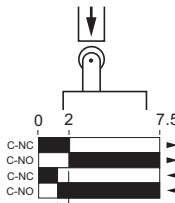
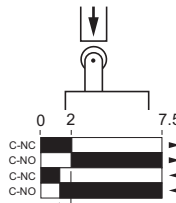
Type of actuation			
Operating diagrams			
Contact operation			
	contact closed		
	contact open		
			

Dimensions in mm

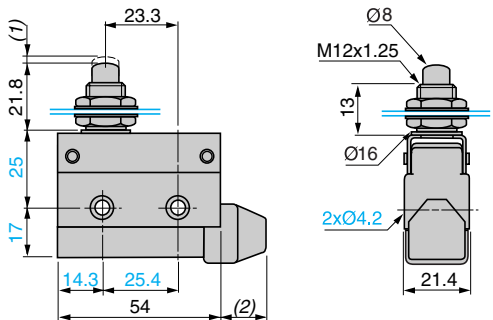
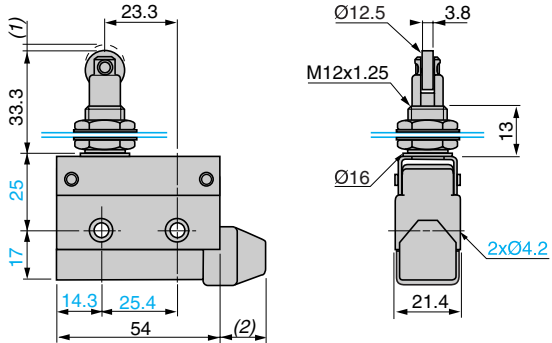
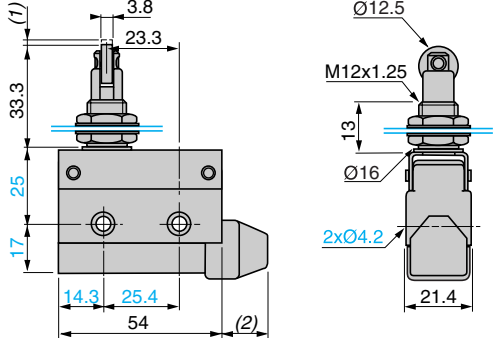
XCJ110C	XCJ102C
 <p>(1) 2 max. (2) 16.5 max.</p>	 <p>(1) 2 max. (2) 16.5 max.</p>
XCJ103C	
 <p>(1) 2 max. (2) 16.5 max.</p>	

Limit switches

XC range

For light to medium duty applications, XCJ

Type of operating head

Plunger (fixing by body)

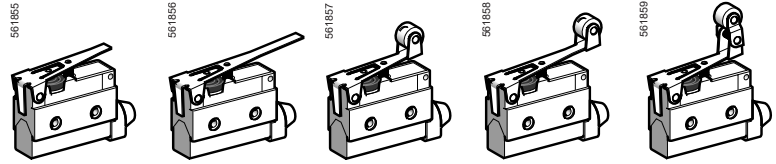

Type of operator

Short flat lever plunger	Long flat lever plunger	Short flat roller lever plunger	Long flat roller lever plunger	Short flat roller lever plunger, one way operation
--------------------------	-------------------------	---------------------------------	--------------------------------	--

References

Single pole 1 C/O (form C)		XCJ125C	XCJ126C	XCJ127C	XCJ128C	XCJ121C
Weight (kg)		0.052	0.053	0.057	0.057	0.059

Complementary characteristics not shown under general characteristics (page 16)

Switch actuation	On end		By 30° cam		
Operating force (maxi.)	1.9 N	1.3 N	2.3 N	1.6 N	2.4 N
Release force (mini.)	0.59 N	0.39 N	0.78 N	0.49 N	0.98 N
Operating frequency	120 operations per minute				
Actuation speed	0.01 mm/s...50 cm/s (at pin plunger)				
Mechanical durability	10 x 10 ⁶ operations				
Cabling	M3.5 screw terminals (use cable lug with flexible cable) Torque range: 0.8...1.2 N.m / 7.08...10.62 lb-in				

Operating diagrams

Type of actuation

Operating diagrams
Contact operation

 ■ contact closed
 □ contact open

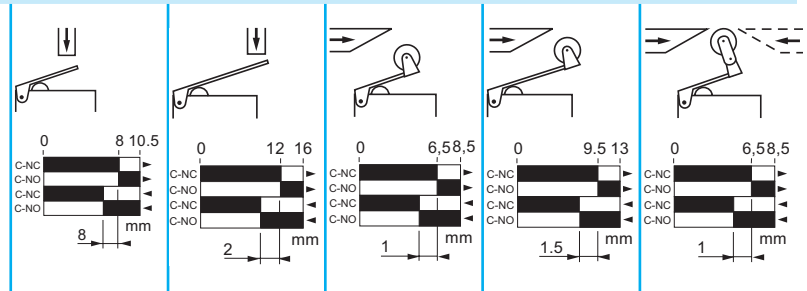

Dimensions in mm

XCJ125C

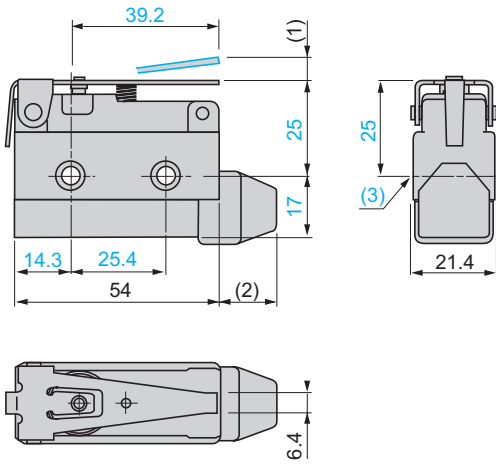

- (1) 8.5 max.
- (2) 16.5 max.
- (3) 2 x Ø 4.2

XCJ127C

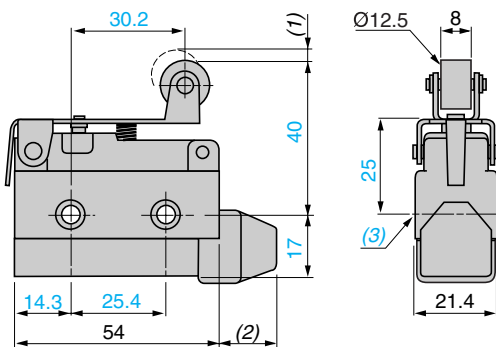

- (1) 6.5 max.
- (2) 16.5 max.
- (3) 2 x Ø 4.2

XCJ121C

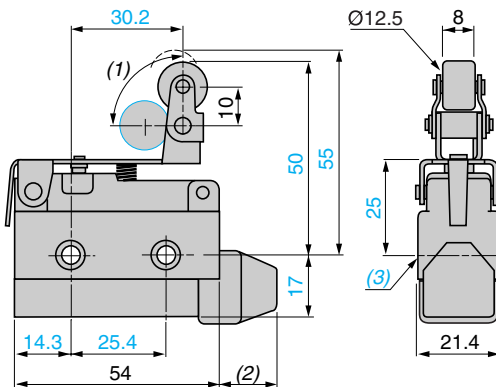

- (1) 90° max.
- (2) 16.5 max.
- (3) 2 x Ø 4.2

XCJ126C

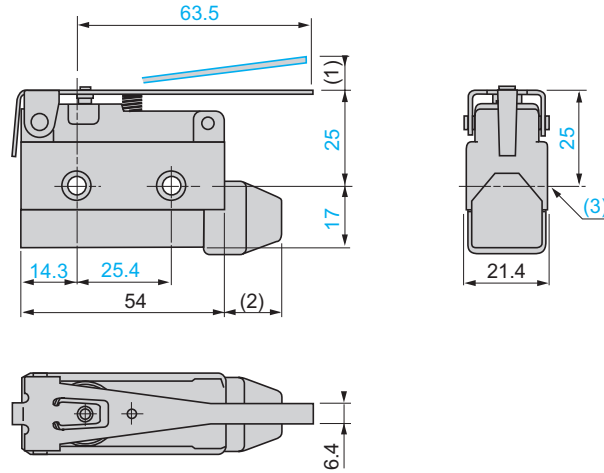

- (1) 13.5 max.
- (2) 16.5 max.
- (3) 2 x Ø 4.2

XCJ128C

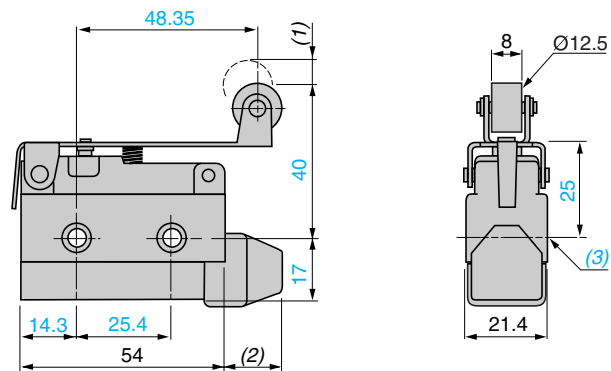

- (1) 11 max.
- (2) 16.5 max.
- (3) 2 x Ø 4.2

X	
XCE110C	11
XCE102C	11
XCE103C	11
XCE118C	12
XCE119C	12
XCE145C	12
XCE146C	12
XCE154C	12
XCE106C	13
XCE181C	13
XCJ110C	17
XCJ102C	17
XCJ103C	17
XCJ125C	18
XCJ126C	18
XCJ127C	18
XCJ128C	18
XCJ121C	18

По вопросам продаж и поддержки обращайтесь:

Алматы (727)345-47-04
Ангарск (3955)60-70-56
Архангельск (8182)63-90-72
Астрахань (8512)99-46-04
Барнаул (3852)73-04-60
Белгород (4722)40-23-64
Благовещенск (4162)22-76-07
Брянск (4832)59-03-52
Владивосток (423)249-28-31
Владикавказ (8672)28-90-48
Владимир (4922)49-43-18
Волгоград (844)278-03-48
Вологда (8172)26-41-59
Воронеж (473)204-51-73
Екатеринбург (343)384-55-89

Иваново (4932)77-34-06
Ижевск (3412)26-03-58
Иркутск (395)279-98-46
Казань (843)206-01-48
Калининград (4012)72-03-81
Калуга (4842)92-23-67
Кемерово (3842)65-04-62
Киров (8332)68-02-04
Коломна (4966)23-41-49
Кострома (4942)77-07-48
Краснодар (861)203-40-90
Красноярск (391)204-63-61
Курск (4712)77-13-04
Курган (3522)50-90-47
Липецк (4742)52-20-81

Магнитогорск (3519)55-03-13
Москва (495)268-04-70
Мурманск (8152)59-64-93
Набережные Челны (8552)20-53-41
Новокузнецк (3843)20-46-81
Ноябрьск (3496)41-32-12
Новосибирск (383)227-86-73
Омск (3812)21-46-40
Орел (4862)44-53-42
Оренбург (3532)37-68-04
Пенза (8412)22-31-16
Петрозаводск (8142)55-98-37
Псков (8112)59-10-37
Пермь (342)205-81-47

Ростов-на-Дону (863)308-18-15
Рязань (4912)46-61-64
Самара (846)206-03-16
Санкт-Петербург (812)309-46-40
Саратов (845)249-38-78
Севастополь (8692)22-31-93
Саранск (8342)22-96-24
Симферополь (3652)67-13-56
Смоленск (4812)29-41-54
Сочи (862)225-72-31
Ставрополь (8652)20-65-13
Сургут (3462)77-98-35
Сыктывкар (8212)25-95-17
Тамбов (4752)50-40-97
Тверь (4822)63-31-35

Тольятти (8482)63-91-07
Томск (3822)98-41-53
Тула (4872)33-79-87
Тюмень (3452)66-21-18
Ульяновск (8422)24-23-59
Улан-Удэ (3012)59-97-51
Уфа (347)229-48-12
Хабаровск (4212)92-98-04
Чебоксары (8352)28-53-07
Челябинск (351)202-03-61
Череповец (8202)49-02-64
Чита (3022)38-34-83
Якутск (4112)23-90-97
Ярославль (4852)69-52-93

Россия +7(495)268-04-70

Казахстан +(727)345-47-04

Беларусь +(375)257-127-884

Узбекистан +998(71)205-18-59

Киргизия +996(312)96-26-47

эл.почта: tuq@nt-rt.ru || сайт: <https://telemecanique.nt-rt.ru>