

Концевые выключатели специального назначения ХС

Технические характеристики

По вопросам продаж и поддержки обращайтесь:

Алматы (727)345-47-04
Ангарск (3955)60-70-56
Архангельск (8182)63-90-72
Астрахань (8512)99-46-04
Барнаул (3852)73-04-60
Белгород (4722)40-23-64
Благовещенск (4162)22-76-07
Брянск (4832)59-03-52
Владивосток (423)249-28-31
Владикавказ (8672)28-90-48
Владимир (4922)49-43-18
Волгоград (844)278-03-48
Вологда (8172)26-41-59
Воронеж (473)204-51-73
Екатеринбург (343)384-55-89

Иваново (4932)77-34-06
Ижевск (3412)26-03-58
Иркутск (395)279-98-46
Казань (843)206-01-48
Калининград (4012)72-03-81
Калуга (4842)92-23-67
Кемерово (3842)65-04-62
Киров (8332)68-02-04
Коломна (4966)23-41-49
Кострома (4942)77-07-48
Краснодар (861)203-40-90
Красноярск (391)204-63-61
Курск (4712)77-13-04
Курган (3522)50-90-47
Липецк (4742)52-20-81

Магнитогорск (3519)55-03-13
Москва (495)268-04-70
Мурманск (8152)59-64-93
Набережные Челны (8552)20-53-41
Нижний Новгород (831)429-08-12
Новокузнецк (3843)20-46-81
Ноябрьск (3496)41-32-12
Новосибирск (383)227-86-73
Омск (3812)21-46-40
Орел (4862)44-53-42
Оренбург (3532)37-68-04
Пенза (8412)22-31-16
Петрозаводск (8142)55-98-37
Псков (8112)59-10-37
Пермь (342)205-81-47

Ростов-на-Дону (863)308-18-15
Рязань (4912)46-61-64
Самара (846)206-03-16
Санкт-Петербург (812)309-46-40
Саратов (845)249-38-78
Севастополь (8692)22-31-93
Саранск (8342)22-96-24
Симферополь (3652)67-13-56
Смоленск (4812)29-41-54
Сочи (862)225-72-31
Ставрополь (8652)20-65-13
Сургут (3462)77-98-35
Сыктывкар (8212)25-95-17
Тамбов (4752)50-40-97
Тверь (4822)63-31-35

Тольятти (8482)63-91-07
Томск (3822)98-41-53
Тула (4872)33-79-87
Тюмень (3452)66-21-18
Ульяновск (8422)24-23-59
Улан-Удэ (3012)59-97-51
Уфа (347)229-48-12
Хабаровск (4212)92-98-04
Чебоксары (8352)28-53-07
Челябинск (351)202-03-61
Череповец (8202)49-02-64
Чита (3022)38-34-83
Якутск (4112)23-90-97
Ярославль (4852)69-52-93

Россия +7(495)268-04-70

Казахстан +(727)345-47-04

Беларусь +(375)257-127-884

Узбекистан +998(71)205-18-59

Киргизия +996(312)96-26-47

эл.почта: tuq@nt-rt.ru || сайт: <https://telemecanique.nt-rt.ru>

Limit switches XC Special range

- **Selection guide**page 2

- **Limit switches XC range: general**
 - Presentation and terminologypage 16
 - Contact blockspage 17
 - Mountingpage 19
 - Setting-uppage 20
 - Reminder of standardspage 22

- **For very severe applications, XC2J**
 - Presentation and characteristicspage 24
 - Complete switches, fixed bodypage 26
 - Variable composition: fixed or plug-in bodypage 28
 - Adaptable sub-assembliespage 30
 - For low temperature applications (- 40 °C)page 36
 - For high temperature applications (+ 120 °C)page 39

- **For hoisting and mechanical handling applications, XCR and XCKMR
For conveyor belt shift monitoring, XCRT**
 - Presentation and characteristicspage 42
 - Switches XCR and XCKMRpage 46
 - Switches XCRTpage 48

- **Subminiature format and microswitches**
 - Generalpage 56
 - DIN 41635 B format, sealedpage 58
 - DIN 41635 A formatpage 60
 - Sealed design, pre-cabledpage 62

- **Overtravel limit switches, XF9**
 - Presentationpage 64
 - Characteristicspage 65
 - Referencespage 66
 - Dimensionspage 67

- **Reference index**page 68

Limit switches

XC Standard range

| Design/Applications | Miniature format | Miniature format for mobile equipments | Compact format, CENELEC EN 50047 |
|---------------------|-------------------|--|----------------------------------|
| | Metal, pre-cabled | Metal, pre-cabled | Plastic, 1 cable entry |



| | | | |
|---|---|--|--|
| Enclosure | Metal | Metal | Plastic, double insulated |
| Modularity | Head, body and connection modularity | Head and body modularity | Head, body and cable entry modularity |
| Conformity/Certifications | CE, UL, CSA, CCC, EAC | CE, UL, CSA | CENELEC EN 50047 UL, CSA, CCC, EAC |
| Body dimensions (w x h x d) in mm | 30 x 50 x 16 | 30 x 50 x 20.5 | 31 x 65 x 30 |
| Head | Linear movement (plunger) Rotary movement (lever) Rotary movement, multidirectional Same heads for ranges XCMD, XCMV, XCKD, XCKP and XCKT | | |
| Contact blocks | | | |
| 2 electrically separate contacts | <ul style="list-style-type: none"> • snap action with positive opening operation • slow break with positive opening operation | <ul style="list-style-type: none"> • • | <ul style="list-style-type: none"> • • |
| 2 same polarity contacts | <ul style="list-style-type: none"> – snap action – slow break | <ul style="list-style-type: none"> – – | <ul style="list-style-type: none"> – – |
| 3 electrically separate contacts | <ul style="list-style-type: none"> • snap action with positive opening operation • slow break with positive opening operation | <ul style="list-style-type: none"> – – | <ul style="list-style-type: none"> • • |
| 4 electrically separate contacts | <ul style="list-style-type: none"> • snap action with positive opening operation – slow break with positive opening operation | <ul style="list-style-type: none"> – – | <ul style="list-style-type: none"> – – |
| 4 contacts (2 x 2 same polarity contacts) | <ul style="list-style-type: none"> – snap action | <ul style="list-style-type: none"> • | <ul style="list-style-type: none"> – |
| Degree of protection IP/IK | IP 66, IP 67, IP 68, IK 06 | IP 66, IP 67, IP 69, IK 04, IK 06 depending on model | IP 66, IP 67, IK 04, |
| Operating temperature | - 25 °C... + 70 °C, -40 °C depending on heads | | |
| Raccordement Screw terminals | – | – | 1 entry for ISO M16 or M20, Pg 11, Pg 13.5 cable gland or 1/2" NPT, PF 1/2 |
| Pre-cabled | Ø 7.5 PVR, CEI, halogen free, depending on model | Ø 6.4 PVR | – |
| Connector | Integral or remote M12 or remote 7/8"-16UN | M12, Deutsch DT04-4P or AMP Superseal 1.5 | M12 |
| Type reference | XCMD | XCMV | XCKP |
| Pages | Please refer to our catalogue "Limit switches XC Standard" | | |

| Compact format, CENELEC EN 50047 | | Compact format, with reset | |
|----------------------------------|----------------------|----------------------------|--------------------------|
| Plastic, 2 cable entries | Metal, 1 cable entry | Plastic, 1 cable entry | Plastic, 2 cable entries |



| | | | |
|--|--|--|--|
| Plastic, double insulated | Metal | Plastic, double insulated | |
| Head and body modularity | Head, body and connection modularity | – | |
| CENELEC EN 50047, UL, CSA, CCC, EAC | | CE, UL, CSA, EAC | |
| 58 x 51 x 30 | 31 x 65 x 30 | 31 x 65 x 30 | 58 x 51 x 30 |
| Linear movement (plunger) Rotary movement (lever) Rotary movement, multidirectional Same heads for ranges XCMD, XCMV, XCKD, XCKP and XCKT | | Linear movement (plunger) Rotary movement (lever) | |
| • | • | • | • |
| • | • | • | • |
| – | – | – | – |
| – | – | – | – |
| • | • | – | – |
| • | • | – | – |
| – | – | – | – |
| – | – | – | – |
| – | – | – | – |
| IP 66, IP 67, IK 04 | IP 66, IP 67, IK 06 | IP 66, IP 67, IK 04 | |
| - 25 °C... + 70 °C | | | |
| 2 entries for ISO M16 or Pg 11 cable gland or 1/2" NPT (using adaptor) | 1 entry for ISO M16 or M20, Pg 11, Pg 13.5 cable gland or 1/2" NPT, PF 1/2 | 1 entry for ISO M20 or Pg 13.5 cable gland or 1/2" NPT | 2 entries for ISO M16 or Pg 11 cable gland or 1/2" NPT (using adaptor) |
| – | – | – | – |
| – | M12 | – | – |
| XCKT | XCKD | XCPR | XCTR |
| Please refer to our catalogue "Limit switches XC Standard" | | | |

Limit switches

XC Standard range

| Design | "Classic" format | | Industrial EN 50041 format | | | | | | | | | | | | | | | | | | | | | | | | | | | | | | | | | | | | | | | | | | | | | | | | | | | | | | | | | | | | | | | | | | | | | | | |
|---|---|--|--|--|---|--|--|--|--|---|---|---|---|---|--|---|---|---|---------------------------|--------------------------|---|---|---|---|---------------|---|---|---|---|--------------|---|---|---|---|----------------------------------|---|---|---|---|---|---|---|---|---|--|---|---|---|---|----------------------------------|---|---|---|---|---|---|---|---|---|--|---|---|---|---|---|---|---|---|---|---------------|--|--|--|--|
| | Metal, 3 cable entries | Metal, 1 cable entry | Plastic, 1 cable entry | Metal, 1 cable entry or connector | | | | | | | | | | | | | | | | | | | | | | | | | | | | | | | | | | | | | | | | | | | | | | | | | | | | | | | | | | | | | | | | | | | | | | |
| | | | | | | | | | | | | | | | | | | | | | | | | | | | | | | | | | | | | | | | | | | | | | | | | | | | | | | | | | | | | | | | | | | | | | | | | | | |
| Enclosure | Metal | | Plastic, double insulated | Metal | | | | | | | | | | | | | | | | | | | | | | | | | | | | | | | | | | | | | | | | | | | | | | | | | | | | | | | | | | | | | | | | | | | | | | |
| Modularity | Head, body and operator modularity | | | | | | | | | | | | | | | | | | | | | | | | | | | | | | | | | | | | | | | | | | | | | | | | | | | | | | | | | | | | | | | | | | | | | | | | | |
| Conformity/Certifications | CE, UL, CSA, CCC, EAC | CE, UL, CSA, EAC | CENELEC EN 50041 UL, CSA, CCC, EAC | | | | | | | | | | | | | | | | | | | | | | | | | | | | | | | | | | | | | | | | | | | | | | | | | | | | | | | | | | | | | | | | | | | | | | | |
| Body dimensions (w x h x d) in mm | 63 x 64 x 30 | 52 x 72 x 30 | 40 x 72.5 x 36 | 40 x 77 x 44 42.5 x 84 x 36 | | | | | | | | | | | | | | | | | | | | | | | | | | | | | | | | | | | | | | | | | | | | | | | | | | | | | | | | | | | | | | | | | | | | | | |
| Head | Linear movement (plunger) Rotary movement (lever) Rotary movement, multidirectional | | | | | | | | | | | | | | | | | | | | | | | | | | | | | | | | | | | | | | | | | | | | | | | | | | | | | | | | | | | | | | | | | | | | | | | | | |
| Contact blocks | <table border="1"> <tr> <td>2 electrically separate contacts</td> <td>•</td> <td>•</td> <td>•</td> <td>•</td> </tr> <tr> <td>• snap action with positive opening operation</td> <td>•</td> <td>•</td> <td>•</td> <td>•</td> </tr> <tr> <td>• slow break with positive opening operation</td> <td>•</td> <td>•</td> <td>•</td> <td>•</td> </tr> <tr> <td>2 same polarity contacts</td> <td>–</td> <td>–</td> <td>–</td> <td>•</td> </tr> <tr> <td>• snap action</td> <td>–</td> <td>–</td> <td>–</td> <td>–</td> </tr> <tr> <td>• slow break</td> <td>•</td> <td>•</td> <td>•</td> <td>•</td> </tr> <tr> <td>3 electrically separate contacts</td> <td>•</td> <td>•</td> <td>•</td> <td>•</td> </tr> <tr> <td>• snap action with positive opening operation</td> <td>•</td> <td>•</td> <td>•</td> <td>•</td> </tr> <tr> <td>• slow break with positive opening operation</td> <td>–</td> <td>–</td> <td>–</td> <td>–</td> </tr> <tr> <td>4 electrically separate contacts</td> <td>–</td> <td>–</td> <td>–</td> <td>–</td> </tr> <tr> <td>• snap action with positive opening operation</td> <td>–</td> <td>–</td> <td>–</td> <td>–</td> </tr> <tr> <td>• slow break with positive opening operation</td> <td>–</td> <td>–</td> <td>–</td> <td>–</td> </tr> <tr> <td>4 contacts (2 x 2 same polarity contacts)</td> <td>–</td> <td>–</td> <td>•</td> <td>•</td> </tr> <tr> <td>• snap action</td> <td></td> <td></td> <td></td> <td></td> </tr> </table> | | | | 2 electrically separate contacts | • | • | • | • | • snap action with positive opening operation | • | • | • | • | • slow break with positive opening operation | • | • | • | • | 2 same polarity contacts | – | – | – | • | • snap action | – | – | – | – | • slow break | • | • | • | • | 3 electrically separate contacts | • | • | • | • | • snap action with positive opening operation | • | • | • | • | • slow break with positive opening operation | – | – | – | – | 4 electrically separate contacts | – | – | – | – | • snap action with positive opening operation | – | – | – | – | • slow break with positive opening operation | – | – | – | – | 4 contacts (2 x 2 same polarity contacts) | – | – | • | • | • snap action | | | | |
| 2 electrically separate contacts | • | • | • | • | | | | | | | | | | | | | | | | | | | | | | | | | | | | | | | | | | | | | | | | | | | | | | | | | | | | | | | | | | | | | | | | | | | | | | |
| • snap action with positive opening operation | • | • | • | • | | | | | | | | | | | | | | | | | | | | | | | | | | | | | | | | | | | | | | | | | | | | | | | | | | | | | | | | | | | | | | | | | | | | | | |
| • slow break with positive opening operation | • | • | • | • | | | | | | | | | | | | | | | | | | | | | | | | | | | | | | | | | | | | | | | | | | | | | | | | | | | | | | | | | | | | | | | | | | | | | | |
| 2 same polarity contacts | – | – | – | • | | | | | | | | | | | | | | | | | | | | | | | | | | | | | | | | | | | | | | | | | | | | | | | | | | | | | | | | | | | | | | | | | | | | | | |
| • snap action | – | – | – | – | | | | | | | | | | | | | | | | | | | | | | | | | | | | | | | | | | | | | | | | | | | | | | | | | | | | | | | | | | | | | | | | | | | | | | |
| • slow break | • | • | • | • | | | | | | | | | | | | | | | | | | | | | | | | | | | | | | | | | | | | | | | | | | | | | | | | | | | | | | | | | | | | | | | | | | | | | | |
| 3 electrically separate contacts | • | • | • | • | | | | | | | | | | | | | | | | | | | | | | | | | | | | | | | | | | | | | | | | | | | | | | | | | | | | | | | | | | | | | | | | | | | | | | |
| • snap action with positive opening operation | • | • | • | • | | | | | | | | | | | | | | | | | | | | | | | | | | | | | | | | | | | | | | | | | | | | | | | | | | | | | | | | | | | | | | | | | | | | | | |
| • slow break with positive opening operation | – | – | – | – | | | | | | | | | | | | | | | | | | | | | | | | | | | | | | | | | | | | | | | | | | | | | | | | | | | | | | | | | | | | | | | | | | | | | | |
| 4 electrically separate contacts | – | – | – | – | | | | | | | | | | | | | | | | | | | | | | | | | | | | | | | | | | | | | | | | | | | | | | | | | | | | | | | | | | | | | | | | | | | | | | |
| • snap action with positive opening operation | – | – | – | – | | | | | | | | | | | | | | | | | | | | | | | | | | | | | | | | | | | | | | | | | | | | | | | | | | | | | | | | | | | | | | | | | | | | | | |
| • slow break with positive opening operation | – | – | – | – | | | | | | | | | | | | | | | | | | | | | | | | | | | | | | | | | | | | | | | | | | | | | | | | | | | | | | | | | | | | | | | | | | | | | | |
| 4 contacts (2 x 2 same polarity contacts) | – | – | • | • | | | | | | | | | | | | | | | | | | | | | | | | | | | | | | | | | | | | | | | | | | | | | | | | | | | | | | | | | | | | | | | | | | | | | | |
| • snap action | | | | | | | | | | | | | | | | | | | | | | | | | | | | | | | | | | | | | | | | | | | | | | | | | | | | | | | | | | | | | | | | | | | | | | | | | | |
| Degree of protection IP/IK | IP 66, IK 06 | | IP 65, IK 03 | IP 66, IK 07 | | | | | | | | | | | | | | | | | | | | | | | | | | | | | | | | | | | | | | | | | | | | | | | | | | | | | | | | | | | | | | | | | | | | | | |
| Operating temperature | - 25°C... + 70°C | | - 25°C... + 70°C - 40°C or + 120°C depending on model | | | | | | | | | | | | | | | | | | | | | | | | | | | | | | | | | | | | | | | | | | | | | | | | | | | | | | | | | | | | | | | | | | | | | | | |
| Connection | <table border="1"> <tr> <td>Screw terminals (entry for cable gland)</td> <td>3 entries for ISO M20, Pg 11 cable gland or 1/2" NPT</td> <td>1 entry incorporating cable gland or tapped 1/2" NPT</td> <td>1 entry for ISO M20, Pg 13.5 cable gland or 1/2" NPT</td> <td>1 entry for ISO M20, Pg 13.5 cable gland or 1/2" NPT</td> </tr> <tr> <td>Pre-cabled</td> <td colspan="4">–</td> </tr> <tr> <td>Connector</td> <td colspan="3">–</td> <td>Integral M12 or 7/8"-16UN</td> </tr> </table> | | | | Screw terminals (entry for cable gland) | 3 entries for ISO M20, Pg 11 cable gland or 1/2" NPT | 1 entry incorporating cable gland or tapped 1/2" NPT | 1 entry for ISO M20, Pg 13.5 cable gland or 1/2" NPT | 1 entry for ISO M20, Pg 13.5 cable gland or 1/2" NPT | Pre-cabled | – | | | | Connector | – | | | Integral M12 or 7/8"-16UN | | | | | | | | | | | | | | | | | | | | | | | | | | | | | | | | | | | | | | | | | | | | | | | | | | | | | | | |
| Screw terminals (entry for cable gland) | 3 entries for ISO M20, Pg 11 cable gland or 1/2" NPT | 1 entry incorporating cable gland or tapped 1/2" NPT | 1 entry for ISO M20, Pg 13.5 cable gland or 1/2" NPT | 1 entry for ISO M20, Pg 13.5 cable gland or 1/2" NPT | | | | | | | | | | | | | | | | | | | | | | | | | | | | | | | | | | | | | | | | | | | | | | | | | | | | | | | | | | | | | | | | | | | | | | |
| Pre-cabled | – | | | | | | | | | | | | | | | | | | | | | | | | | | | | | | | | | | | | | | | | | | | | | | | | | | | | | | | | | | | | | | | | | | | | | | | | | |
| Connector | – | | | Integral M12 or 7/8"-16UN | | | | | | | | | | | | | | | | | | | | | | | | | | | | | | | | | | | | | | | | | | | | | | | | | | | | | | | | | | | | | | | | | | | | | | |
| Type reference | XCKM | XCKL | XCKS | XCKJ | | | | | | | | | | | | | | | | | | | | | | | | | | | | | | | | | | | | | | | | | | | | | | | | | | | | | | | | | | | | | | | | | | | | | | |
| Pages | Please refer to our catalogue "Limit switches XC Standard" | | | | | | | | | | | | | | | | | | | | | | | | | | | | | | | | | | | | | | | | | | | | | | | | | | | | | | | | | | | | | | | | | | | | | | | | | |

Limit switches

XC Basic range

| Design | Miniature format | Compact format EN 50047 | | Compact format, with reset knob | | | | | | | | | | | | | | | | | | | | | | | | | | | | | | | | | | | | | | | | | | | | | |
|-----------------------------------|---|---|--|---|---|---|---|--|---|---|---|---|---|---|---|---|---|---|---|---|---|---|---|---|---|---|---|---|---|---|---|---|---|---|---|---|---|---|---|---|---|---|---|---|---|---|---|---|---|
| | Plastic, pre-cabled | Plastic, 1 cable entry | Plastic, 2 cable entries | Plastic, 1 cable entry | | | | | | | | | | | | | | | | | | | | | | | | | | | | | | | | | | | | | | | | | | | | | |
| | | | | | | | | | | | | | | | | | | | | | | | | | | | | | | | | | | | | | | | | | | | | | | | | | |
| Enclosure | Plastic, double insulated | | | | | | | | | | | | | | | | | | | | | | | | | | | | | | | | | | | | | | | | | | | | | | | | |
| Modularity | – | | | | | | | | | | | | | | | | | | | | | | | | | | | | | | | | | | | | | | | | | | | | | | | | |
| Conformity/Certifications | CE, cULus, CCC | CE, UL, CSA, CCC, EAC | CENELEC EN 50047, UL, CSA, CCC, EAC | | | | | | | | | | | | | | | | | | | | | | | | | | | | | | | | | | | | | | | | | | | | | | |
| Body dimensions (w x h x d) in mm | 30 x 50 x 16 | 30 x 50 x 16 | 31 x 65 x 30 | 59 x 51 x 30 31 x 65 x 30 | | | | | | | | | | | | | | | | | | | | | | | | | | | | | | | | | | | | | | | | | | | | | |
| Head | Linear movement (plunger) Rotary movement (lever) Rotary movement, multidirectional | | | | | | | | | | | | | | | | | | | | | | | | | | | | | | | | | | | | | | | | | | | | | | | | |
| Contact blocks | <table border="1"> <tr> <td>•</td> <td>•</td> <td>•</td> <td>•</td> <td>•</td> </tr> <tr> <td>–</td> <td>–</td> <td>•</td> <td>•</td> <td>•</td> </tr> <tr> <td>•</td> <td>–</td> <td>–</td> <td>–</td> <td>–</td> </tr> <tr> <td>–</td> <td>–</td> <td>–</td> <td>•</td> <td>–</td> </tr> <tr> <td>–</td> <td>–</td> <td>•</td> <td>–</td> <td>•</td> </tr> <tr> <td>–</td> <td>–</td> <td>–</td> <td>–</td> <td>–</td> </tr> <tr> <td>–</td> <td>–</td> <td>–</td> <td>–</td> <td>–</td> </tr> <tr> <td>–</td> <td>–</td> <td>–</td> <td>–</td> <td>–</td> </tr> <tr> <td>–</td> <td>–</td> <td>–</td> <td>–</td> <td>–</td> </tr> </table> | | | | • | • | • | • | • | – | – | • | • | • | • | – | – | – | – | – | – | – | • | – | – | – | • | – | • | – | – | – | – | – | – | – | – | – | – | – | – | – | – | – | – | – | – | – | – |
| • | • | • | • | • | | | | | | | | | | | | | | | | | | | | | | | | | | | | | | | | | | | | | | | | | | | | | |
| – | – | • | • | • | | | | | | | | | | | | | | | | | | | | | | | | | | | | | | | | | | | | | | | | | | | | | |
| • | – | – | – | – | | | | | | | | | | | | | | | | | | | | | | | | | | | | | | | | | | | | | | | | | | | | | |
| – | – | – | • | – | | | | | | | | | | | | | | | | | | | | | | | | | | | | | | | | | | | | | | | | | | | | | |
| – | – | • | – | • | | | | | | | | | | | | | | | | | | | | | | | | | | | | | | | | | | | | | | | | | | | | | |
| – | – | – | – | – | | | | | | | | | | | | | | | | | | | | | | | | | | | | | | | | | | | | | | | | | | | | | |
| – | – | – | – | – | | | | | | | | | | | | | | | | | | | | | | | | | | | | | | | | | | | | | | | | | | | | | |
| – | – | – | – | – | | | | | | | | | | | | | | | | | | | | | | | | | | | | | | | | | | | | | | | | | | | | | |
| – | – | – | – | – | | | | | | | | | | | | | | | | | | | | | | | | | | | | | | | | | | | | | | | | | | | | | |
| Degree of protection IP/IK | IP 66, IP 67, IK 04 | IP 65, IK 04 | | | | | | | | | | | | | | | | | | | | | | | | | | | | | | | | | | | | | | | | | | | | | | | |
| Operating temperature | - 25°C... + 70 °C | | | | | | | | | | | | | | | | | | | | | | | | | | | | | | | | | | | | | | | | | | | | | | | | |
| Connection | <table border="1"> <tr> <td>–</td> <td>–</td> <td>1 entry for ISO M20 or Pg 11 cable gland Other cable entries: ISO M16 x 1.5 or PF 1/2 (G1/2)</td> <td>2 entries for ISO M16 or Pg 11 cable gland or 1/2" NPT (using adaptor)</td> <td>1 entry for ISO M20 or Pg 11 cable gland Other cable entries: ISO M16 x 1.5 or PF 1/2 (G1/2)</td> </tr> </table> | | | | – | – | 1 entry for ISO M20 or Pg 11 cable gland Other cable entries: ISO M16 x 1.5 or PF 1/2 (G1/2) | 2 entries for ISO M16 or Pg 11 cable gland or 1/2" NPT (using adaptor) | 1 entry for ISO M20 or Pg 11 cable gland Other cable entries: ISO M16 x 1.5 or PF 1/2 (G1/2) | | | | | | | | | | | | | | | | | | | | | | | | | | | | | | | | | | | | | | | | |
| – | – | 1 entry for ISO M20 or Pg 11 cable gland Other cable entries: ISO M16 x 1.5 or PF 1/2 (G1/2) | 2 entries for ISO M16 or Pg 11 cable gland or 1/2" NPT (using adaptor) | 1 entry for ISO M20 or Pg 11 cable gland Other cable entries: ISO M16 x 1.5 or PF 1/2 (G1/2) | | | | | | | | | | | | | | | | | | | | | | | | | | | | | | | | | | | | | | | | | | | | | |
| Type reference | XCMH | XCMN | XCKN | XCNT XCNR | | | | | | | | | | | | | | | | | | | | | | | | | | | | | | | | | | | | | | | | | | | | | |
| Pages | Please refer to our catalogue "Limit switches XC Standard" | | | | | | | | | | | | | | | | | | | | | | | | | | | | | | | | | | | | | | | | | | | | | | | | |

Limit switches XC Special range

| | | | | |
|---------------------|--------------------------|--|---|--|
| Design/Applications | Very severe applications | For hoisting and material handling applications (XCR); for conveyor belt shift monitoring (XCRT) | For hoisting and material handling applications | Subminiature format and microswitch. Applications requiring high precision and a low operating force |
| | Metal, 1 cable entry | Metal or polyester, 1 cable entry | Metal or plastic, 3 cable entries | Plastic, pre-cabled |

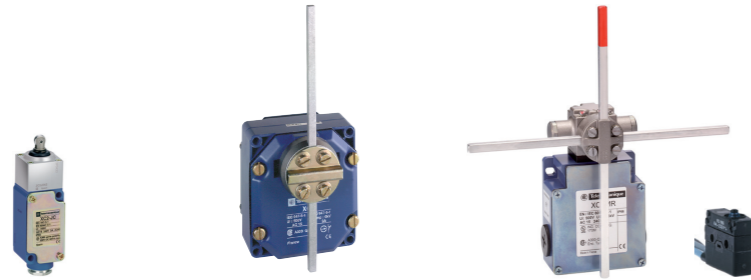

| | | | | |
|---|---|---|--|--|
| Enclosure | Metal | Metal or polyester | Metal or plastic | Polyester |
| Modularity | Head and body modularity | – | – | – |
| Conformity/Certifications | CE, UL, CSA, EAC | CE, CSA (XCR), CCC (XCR), EAC | CE, UL, CSA, CCC, EAC | CE, UL |
| Body dimensions (w x h x d) in mm | 40 x 81 x 41 | 85 x 95 x 75 | 118 x 77 x 59 (metal) 118 x 77 x 67 (plastic) | Depending on model |
| Head | Linear movement (plunger) or rotary movement (lever) | Rotary movement (lever) | Rotary movement (lever) | – |
| Contact blocks | 2 same polarity contacts snap action | – | – | • |
| 4 electrically separate contacts snap action with positive opening operation | – | • | – | – |
| slow break with positive opening operation | – | • | • | – |
| 4 contacts (2 x 2 same polarity contacts), snap action | • | • | – | – |
| Degree of protection IP/IK | IP 65, IK 08 | IP 54, IK 07 or IP 65, depending on model | IP 66, IK 07 (metal) IP 65, IK 04 (plastic) | IP 67 or IP 40 depending on model IP 00 (tags) |
| Operating temperature | - 25°C... + 70°C; - 40° C or + 120° C (XC2J depending on model) | - 25 °C... + 70 °C | - 25 °C... + 70 °C | - 40 °C... + 105 °C, - 40° C... + 125° C selon modèle |
| Connection | Screw terminals (entry for cable gland) | 1 entry with integral cable gland | 1 tapped entry for Pg 13.5 cable gland | 3 tapped entries for Pg 13.5 cable gland or tapped M20 x 1.5, depending on model |
| Type reference | XC2J | XCR XCRT | XCKMR XCKVR | XEP |
| Pages | 26 | 46 and 48 | 52 | 58 |

Overtravel limit switches XF9 range

| | |
|---------------------|---|
| Design/Applications | Overtravel limit switches for power circuits For hoisting applications |
| | Aluminium alloy case or sheet steel enclosure 2 or 3 cable entries |



| | | |
|--|--|---|
| Enclosure | Aluminium alloy case | Sheet steel enclosure |
| Reset | Manual | Manual or automatic, depending on model |
| Conformity/Certifications | CSA, IEC 60158-1, NF C 63-110, VDE 0660, IEC 947-1, IEC 60947-4 | |
| Body dimensions (w x h x d) in mm | Depending on model | |
| Head | Rotary movement | |
| Number of poles | 4 | 3 |
| Rated operational current (Ie) | For 2-pole scheme | 50 A or 130 A, depending on model |
| | For 3-pole scheme on AC-3 | 25 A or 65 A, depending on model |
| Conventional thermal current (Ithe) at θ ≤ 40 °C | For 2-pole scheme | 80 A or 160 A, depending on model |
| | For 3-pole scheme | 40 A or 80 A, depending on model |
| Rated insulation voltage (Ui) | Conforming to IEC 60158-1, IEC 947-4, VDE 0110 Group C | 500 V |
| | Conforming to CSA 22-2 n° 14 | 600 V |
| Rated breaking capacity | Conforming to IEC 60158-1 | 400 A or 1000 A, depending on model |
| | For 2-pole scheme | 180 A or 630 A, depending on model |
| Degree of protection | IP 54 | IP 43 |
| Operating temperature | - 25 °C... + 70 °C | |
| Cable entry | 2 tapped entries for n° 21 cable gland or 3 tapped entries for n° 29 cable gland, depending on model | 2 entries incorporating n° 36 plastic cable gland |
| Type reference | XF9D | XF9F |
| Pages | 66 | 66 |

Safety detection solutions

XCS safety switches

| Switch type | XCS safety limit switches | |
|--------------|--|--------------------|
| Applications | Protection of operators by stopping the machine when the gate is opened. All machines with quick rundown time. | |
| Design | Miniature format | Compact format |
| | Pre-cabled | With 1 cable entry |



| | | | |
|------------------------------|--|---|-------------|
| Case | Metal | Plastic | Metal |
| Features | - | | |
| Conformity to standards | EN/IEC 60947-5-1, EN/ISO 13849-1, EN/IEC 62061, UL 508, CSA C22-2 no. 14 | | |
| Products | Machine assemblies | | |
| EN/IEC 60204-1, EN/ISO 14119 | | | |
| Product certifications | UL, CSA, CCC, EAC | | |
| Dimensions (w x h x d) in mm | Switch | Fixings | Centers |
| | 30 x 50 x 16 | 31 x 34 x 89 | |
| | 20 | 20/22 | |
| Head | Plunger or rotary head Head adjustable in 15° steps through 360° Linear (plunger) or rotary (lever) actuation. | | |
| Contact blocks | NC contacts with positive opening operation | | |
| | 2 NC + 1 NO break before make, slow break 2 NC + 1 NO and 2 NC + 2 NO snap action | XCSD: 2 NC + 1 NO break before make, slow break or snap action XCSP: 2 NC + 1 NO snap action | |
| Degree of protection | IP 66, IP 67 and IP 68 | IP 66 and IP 67 | |
| Ambient air temperature | For operation | -25...+70 °C | |
| Connection | Screw terminals (cable entry via cable gland) | Tapped entry for Pg 13.5, ISO M20 cable gland or tapped 1/2" NPT | |
| | Pre-cabled | L = 1, 2 or 5 m | |
| Type reference | XCSM | XCSP | XCSD |
| Pages | Please refer to our catalogue "Safety switches XCS range" | | |

| XCS lever or spindle-operated safety switches | | |
|--|--|--|
| Protection of operators by stopping the machine when the operating lever (attached to hinged machine guard) is displaced by 5°. All light industrial machines fitted with hinged or rotary protective covers with small opening radius. | Protection of operators by stopping the machine when the guard hinge rotates through 5°. All light industrial machines fitted with hinged access doors. | |
| Compact format | With 1 or 2 cable entries | |



| | | |
|--|---|--|
| Plastic, double insulated | | |
| 2 types of lever: straight or elbowed (flush with rear of switch) 3 lever positions: to left, center or to right | 2 types of spindle: length 30 mm or 80 mm | |
| EN/IEC 60947-5-1, EN/ISO 13849-1, EN/IEC 62061, UL 508, CSA C22-2 no. 14, JIS C4520 | | |
| EN/IEC 60204-1, EN/ISO 14119 | | |
| UL, CSA, CCC, EAC | | |
| 30 x 87.5 x 30 | 30 x 96 x 30 | 52 x 117 x 30 |
| 20/22 | 20/22 | 20/22 or 40.3 |
| Turret head: 4 positions Rotary actuation (lever) | Turret head: 4 positions Rotary actuation (spindle) | |
| Slow break safety contacts with positive opening operation NC contacts open when lever or spindle displaced by more than 5° | | |
| 1 NC + 1 NO break before make 2 NC 1 NC + 2 NO break before make 2 NC + 1 NO break before make | 1 NC + 1 NO break before make 2 NC 1 NC + 2 NO break before make 2 NC + 1 NO break before make | 1 NC + 2 NO break before make 2 NC + 1 NO break before make 3 NC |
| IP 67 | IP 67 | |
| -25...+70 °C | | |
| 1 tapped entry for Pg 11, ISO M16 cable gland or tapped 1/2" NPT | 1 tapped entry for Pg 11, ISO M16 cable gland or tapped 1/2" NPT | 2 tapped entries for Pg 11, ISO M16 cable gland or tapped 1/2" NPT |
| - | - | - |
| XCSP | XCSPR | XCSTR |
| Please refer to our catalogue "Safety switches XCS range" | | |

Safety detection solutions

XCS safety switches

| | | |
|---------------------|--|----------------------------------|
| Switch type | XCS key-operated safety switches | |
| Applications | Protection of operators by stopping the machine when the actuating key (attached to machine guard) is withdrawn from the head of the switch. All light industrial machines with quick rundown time (1). | |
| Design | Miniature format | Compact format |
| | Pre-cabled | With 1 or 2 cable entries |



| | | | |
|-------------------------------------|--|---|--|
| Case | Plastic | | |
| Features | Without locking of actuating key. | Without locking of actuating key. Optional accessory: guard retaining device. | |
| | EN/IEC 60947-5-1, EN/ISO 13849-1, EN/IEC 62061, UL 508, CSA C22-2 no. 14 EN/IEC 60204-1, EN/ISO 14119 | | |
| Conformity to standards | Products | EN/IEC 60947-5-1, EN/ISO 13849-1, EN/IEC 62061, UL 508, CSA C22-2 no. 14 | |
| | Machine assemblies | EN/IEC 60204-1, EN/ISO 14119 | |
| Product certifications | | cULus | UL, CSA, CCC, EAC |
| Dimensions (w x h x d) in mm | Switch | 30 x 87 x 15 | 30 x 93.5 x 30 |
| | Fixings | Centers: 20/22 | Centers: 20/22 or 40.3 |
| Head | | Fixed head: 2 positions for insertion of actuating key. | Turret head: 8 positions for insertion of actuating key. |
| Contact blocks | Safety contacts actuated by the actuating key. Slow break and NC positive opening operation. | | |
| | 1 NC + 1 NO break before make 2 NC 2 NC + 1 NO break before make 3 NC | 1 NC + 1 NO slow break contacts, break before make or make before break, or snap action 2 NC slow break or snap action 2 NC + 1 NO slow break contacts, break before make, or snap action 1 NC + 2 NO slow break contacts, break before make, or snap action | 1 NC + 2 NO break before make 2 NC + 1 NO break before make 3 NC |
| | IP 67 | | |
| Degree of protection | IP 67 | | |
| Ambient air temperature | For operation | -25...+70 °C | |
| Connection | Screw terminals (cable entry via cable gland) | Tapped entry for Pg 11, ISO M16 cable gland or tapped 1/2" NPT | |
| | Pre-cabled | L = 2, 5 or 10 m | - |
| Type reference | XCSMP | XCSPA | XCSTA |
| Pages | Please refer to our catalogue "Safety switches XCS range" | | |

(1) Machine stopping time less than time taken for operator to access hazardous zone.

| | | |
|---|--|--|
| XCS key-operated safety switches | | |
| All heavy industrial machines with quick rundown time (1) | | |
| Industrial format with or without locking | | |
| With 1 cable entry, without locking | With 1 cable entry and manual locking/unlocking | |

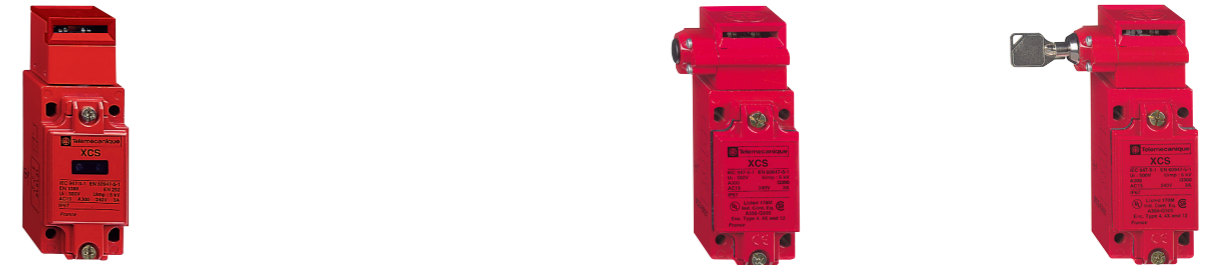

| | | | |
|-------------------------------------|--|---|--|
| Case | Metal | | |
| Features | Without locking of actuating key. | Manual locking and unlocking of actuating key by pushbutton (can be mounted on left or right-hand side of switch head). | Manual locking and unlocking of actuating key by key-operated lock (can be mounted on left or right-hand side of switch head). |
| | EN/IEC 60947-5-1, EN/ISO 13849-1, EN/IEC 62061, UL 508, CSA C22-2 no. 14 EN/IEC 60204-1, EN/ISO 14119 | | |
| Conformity to standards | Products | EN/IEC 60947-5-1, EN/ISO 13849-1, EN/IEC 62061, UL 508, CSA C22-2 no. 14 | |
| | Machine assemblies | EN/IEC 60204-1, EN/ISO 14119 | |
| Product certifications | | UL, CSA, CCC, EAC | |
| Dimensions (w x h x d) in mm | Switch | 40 x 113.5 x 44 | 52 x 113.5 x 44 |
| | Fixings | 30 x 60 | 30 x 60 |
| Head | | Turret head: 8 positions for insertion of actuating key. | Turret head: 8 positions for insertion of actuating key. |
| Contact blocks | Safety contacts actuated by the actuating key. Slow break and NC positive opening operation. | | |
| | 1 NC + 2 NO break before make 2 NC + 1 NO break before make 3 NC | 1 NC + 2 NO break before make 2 NC + 1 NO break before make 3 NC | 1 NC + 2 NO break before make 2 NC + 1 NO break before make 3 NC |
| | IP 67 | | |
| Degree of protection | IP 67 | | |
| Ambient air temperature | For operation | -25...+70 °C | |
| Connection | Screw clamp terminals. Tapped entry for Pg 13.5, ISO M20 cable gland or tapped 1/2" NPT | Screw clamp terminals. Tapped entry for Pg 13.5 cable gland, ISO M20 or tapped 1/2" NPT. | |
| | Pre-cabled | - | - |
| Type reference | XCSA | XCSB | XCSC |
| Pages | Please refer to our catalogue "Safety switches XCS range" | | |

Safety detection solutions

XCS safety switches

| | | |
|--------------|---|----------------------|
| Switch type | XCS key-operated safety switches, locking and unlocking by solenoid | |
| Applications | Protection of operators by stopping the machine when the actuating key (attached to machine guard) is withdrawn from the head of the switch. All industrial machines with long rundown time (1) | |
| Design | Slim format | |
| | With 3 cable entries | With 3 cable entries |



| | | |
|---|--|---|
| Case | Plastic | Metal |
| Features | Locking and unlocking of actuating key using a solenoid (either on energization or on de-energization). Manual unlocking (auxiliary release using special tool) of actuating key in abnormal conditions. | Locking and unlocking of actuating key by solenoid (either on energization or on de-energization). Manual unlocking (auxiliary release using key lock) of actuating key in abnormal conditions. 1 Emergency release mushroom head pushbutton (only for XCSLF●●●●4●● and XCSLF●●●●6●●). |
| Conformity to standards | EN/IEC 60947-5-1, EN/ISO 13849-1, EN/IEC 62061, UL 508 and CSA C22-2 no. 14 | |
| Products | EN/IEC 60204-1, EN/ISO 14119 | |
| Machine assemblies | UL, CSA, CCC, EAC | |
| Product certifications | 51 x 205 x 43.5 | |
| Dimensions (w x h x d or Ø) in mm | Switch | Centers |
| | Fixings | Centers |
| | 30 x 153.3 | |
| Head | Turret head: 8 positions for insertion of actuating key. | |
| Resistance to forcible withdrawal of the actuator | F _{1max} | 3000 N |
| | F _{Zh} | 2300 N |
| Contact blocks or outputs | Main safety contacts actuated by the actuating key; auxiliary contacts actuated by solenoid. Contact states given with key inserted and solenoid not energized. Slow break and NC positive opening operation | |
| | Main contacts | 1 NC + 1 NO break before make 2 NC 1 NC + 2 NO break before make 2 NC + 1 NO break before make 3 NC |
| | Auxiliary contacts | 1 NC + 1 NO break before make 2 NC 1 NC + 2 NO break before make 2 NC + 1 NO break before make 3 NC |
| Degree of protection | IP 66/IP 67 | |
| Ambient air temperature | For operation | -25...+60 °C |
| | For storage | -40...+70 °C |
| Connection | Terminals | Spring terminals, 3 cable entries. Tapped entry for ISO M20 cable gland or tapped 1/2" NPT. |
| | Connector | M23 (18 + 1 PE) |
| Type reference | XCSLE | XCSLF |
| Pages | Please refer to our catalogue "Safety switches XCS range" | |

(1) Machine stopping time greater than time taken for operator to access hazardous zone.

| | | |
|--------------|---|----------------------|
| Switch type | XCS key-operated safety switches, locking and unlocking by solenoid (continued) | |
| Applications | Protection of operators by stopping the machine when the actuating key (attached to machine guard) is withdrawn from the head of the switch. All industrial machines with long rundown time (1) | |
| Design | Rectangular | |
| | - | With 2 cable entries |



| | | |
|---|--|---|
| Case | Plastic, double insulated | Metal |
| Features | Locking and unlocking of actuator by solenoid (either on de-energization or on energization). Manual unlocking (auxiliary release using special tool) of actuating key in abnormal conditions. | Locking and unlocking of actuating key by solenoid (either on energization or on de-energization). Manual unlocking (auxiliary release using key lock) of actuating key in abnormal conditions. |
| Conformity to standards | EN/IEC 60947-5-1, EN/ISO 13849-1, UL 508, CSA C22-2 no. 14, EN/IEC 62061, EN/IEC 60947-1 | |
| Products | EN/IEC 60204-1, EN/ISO 14119 | |
| Machine assemblies | UL, CSA, CCC, EAC | UL, CSA, CCC, EAC |
| Product certifications | 110 x 93.5 x 33 | 98 x 146 x 44 |
| Dimensions (w x h x d or Ø) in mm | Switch | Centers |
| | Fixings | Centers |
| | 30 x 153.3 | 88 x 95 |
| Head | Turret head: 8 positions for insertion of actuating key | |
| Resistance to forcible withdrawal of the actuator | 650 N | 2600 N |
| | 500 N | 2000 N |
| Contact blocks or outputs | Main safety contacts actuated by the actuating key; auxiliary contacts actuated by solenoid. Slow break and NC positive opening operation | |
| | 1 NC + 1 NO break before make 1 NC + 1 NO make before break 2 NC | 1 NC + 2 NO break before make 2 NC + 1 NO break before make 3 NC |
| | 1 NC | 1 NC + 1 NO 2 NC |
| Degree of protection | IP 67 | |
| Ambient air temperature | For operation | -25...+60 °C |
| | For storage | -40...+70 °C |
| Connection | Terminals | Screw clamp terminals. 2 tapped entries for Pg 13.5 ISO M20 cable gland or tapped 1/2" NPT. |
| | Connector | - |
| Type reference | XCSLE | XCSLF |
| Pages | Please refer to our catalogue "Safety switches XCS range" | |

Safety detection solutions

XCS safety switches

| | | | |
|--|--|--|--|
| Switch type | XCSR contactless RFID safety switches | | |
| Applications | Highly tamper-proof protection of operators by stopping the machine when the gate is opened (transfer lines, assembly lines, automated equipment, machine tools, etc.). All light industrial machines fitted with access gates with imprecise guidance and/or subjected to frequent washing, shocks and vibrations. This safety switch is suitable for machine with low inertia. | | |
| Design | Rectangular format M12 connector | | |
| Case | Thermoplastic housing (Valox TM) | | |
| Features | Contactless system composed of a microprocessor-controlled switch and a transponder factory-paired with a unique code. Multiposition sensor transponder. | | |
| Assured operating sensing distance (Sao) | 15 mm | | |
| Assured release distance (Sar) | 35 mm | | |
| Type of switch | Standalone RFID switch | Daisy-chain RFID switch for direct series connection | Single RFID switch for point-to-point connection |
| Operating mode | Possible functioning without association with a safety control unit (Integrated External Device Monitoring (EDM) and Start/Restart function) Functioning in combination with a safety control unit PL=e/Cat4 - SIL 3 | | |
| Conformity to standards | Products Machine assemblies RFID protocol | | |
| Product certifications | EN/IEC 60947-5-2, EN/IEC 60947-5-3, UL 508, CSA C22.2 SIL 3 (IEC 61508), SILCL 3 (IEC 62061), PLe-Cat. 4 (EN ISO 13849-1) EN/IEC 60204-1, EN/ISO 14119 Based on ISO 15693 | | |
| Dimensions (w x h x d or Ø) in mm | CE, cULus, TÜV, FCC, EAC, IC, RCM, E2, ECOLAB | | |
| Switch | 30 x 108.3 x 15 | 30 x 118.6 x 5 | 30 x 108.3 x 15 |
| Transponder | 50 x 15 x 15 | | |
| Fixings | Centers | | |
| | Reader | | |
| | Transponder | | |
| 74...78 | 30...34 | | |
| Contact blocks or outputs | Safety output Contact states given in presence of magnet | | |
| | 2 OSSDs (Safety outputs PNP NO). OSSDs are in the ON state when the gate is closed Maximum current 400mA Maximum current 200 mA | | |
| Degree of protection | Conforming to EN/IEC 60529 Conforming to DIN 40050 | | |
| IP 65, IP 66, IP 67 | IP 69K | | |
| Ambient air temperature | For operation For storage | | |
| -25...+70 °C | -40...+85 °C | | |
| Connection | Pre-cabled Connector Conforming to EN/IEC 60947-5-2-A3 and EN/IEC 61076 | | |
| 1 M12 8-pin connector (A coding) | 2 M12 5-pin connector (A coding) | 1 M12 5-pin connector (A coding) | |
| Type reference | XCSRC•1•M12 | XCSRC•2M12 | XCSRC•0M12 |
| Pages | Please refer to our catalogue "Safety switches XCS range" | | |



| | | |
|--|---|---|
| XCS safety coded magnetic safety switches for detection without contact | | |
| Protection of operators by stopping the machine when the gate is opened All light industrial machines fitted with access gates with imprecise guidance and/or subjected to frequent washing This Safety sensor is suitable for machine with low inertia. | | |
| Miniature rectangular format | Compact rectangular format | Cylindrical format |
| Pre-cabled or M8 connector on flying lead | Pre-cabled or M12 connector on flying lead | |
| Plastic | 3 approach directions | |
| 5 mm | 8 mm | 1 approach direction |
| 15 mm | 20 mm | |
| – | | |
| – | | |
| – | | |
| EN/IEC 60947-5-1, EN/ISO 13849-1, EN/IEC 62061, UL 508 and CSA C22-2 no. 14 | | |
| EN/IEC 60204-1, EN/ISO 14119 | | |
| – | | |
| UL, CSA, EAC, ECOLAB | | |
| 16 x 51 x 7 | 25 x 88 x 13 | Ø 30, L 38.5 |
| – | | |
| 16 | 78 | – |
| – | | |
| – | | |
| 1 NC + 1 NO staggered 2 NC staggered Independent Reed-type contacts operated by coded magnet. | 1 NC + 1 NO staggered 2 NC staggered 2 NC + 1 NO (NC staggered) 1 NC + 2 NO (NO staggered) | 1 NC + 1 NO staggered 2 NC staggered |
| To be used with safety control units. | | |
| IP 66 and IP 67 for pre-cabled version, IP 67 for connector on flying lead version | | |
| – | | |
| – | | |
| -25...+85 °C | | |
| – | | |
| L = 2, 5 or 10 m | | |
| M8, on 0.15 m flying lead | M12, on 0.15 m flying lead | |
| – | – | – |
| XCSDMC | XCSDMP | XCSDMR |
| Please refer to our catalogue "Safety switches XCS range" | | |

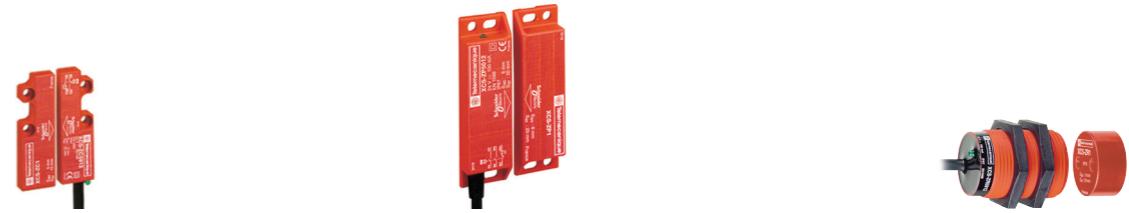

Presentation

Electromechanical detection

Limit switches are used in all automated installations and also in a wide variety of applications, due to the numerous advantages inherent to their technology. They transmit data to the logic processing system regarding:

- presence/absence,
- passing,
- positioning,
- end of travel.

Simplicity of installation, advantages

■ From an electrical viewpoint

- galvanic separation of circuits,
- models suitable for low power switching combined with good electrical durability,
- very good short-circuit withstand in coordination with appropriate fuses,
- total immunity to electromagnetic interference,
- high rated operational voltage.

■ From a mechanical viewpoint

- NC contacts with positive opening operation,
- high resistance to the different ambient conditions encountered in industry (standard tests and specific tests under laboratory conditions),
- high repeat accuracy, up to 0.01 mm on the tripping points.

Detection movements

- Linear movement (plunger)
- Rotary movement (lever)
- Multi-directional movement

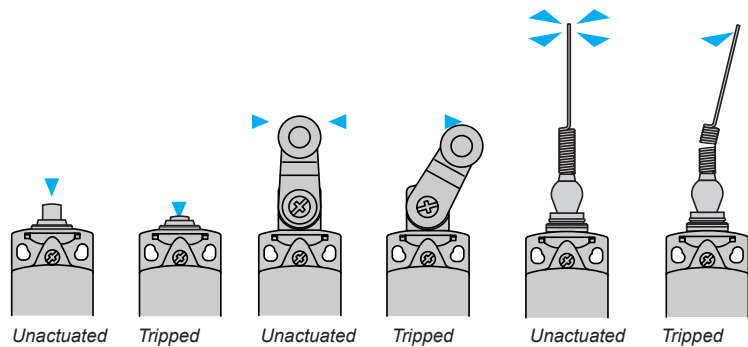

Terminology

| | |
|-----------------------------------|---|
| Rated value of a quantity | <ul style="list-style-type: none"> ■ This replaces the term “nominal value”. ■ It is the fixed value for a specific function. |
| Utilisation categories: | <ul style="list-style-type: none"> ■ AC-15 replaces AC-11: control of an electromagnet on AC, test 10 Ie/Ie. ■ AC-12: control of a resistive load on AC or static load isolated by opto-coupler. ■ DC-13 replaces DC-11: control of an electromagnet on DC, test Ie/Ie. |
| Positive opening travel | ■ Minimum travel from the initial movement of contact actuator to the position required to accomplish positive opening operation. |
| Positive opening force | ■ The force required on the contact actuator to accomplish positive opening operation. |
| Switching capacity | <ul style="list-style-type: none"> ■ I_{th} is no longer a rated value but a conventional current used for heating tests. Example: for category A300 the corresponding operational current, I_e maximum, is 6 A-120 V or 3 A-240 V, the equivalent I_{th} being 10 A. |
| Positive opening operation | <ul style="list-style-type: none"> ■ A limit switch complies to this specification when all the closed contact elements of the switch can be changed, with certainty, to the open position (no flexible link between the moving contacts and the operator of the switch, to which an actuating force is applied). ■ All limit switches incorporating either a slow break contact block or a snap action NC + NO (form Zb), NC + NO + NO, NC + NC + NO, NC + NC + NO + NO contact block are positive opening operation, in complete conformity with standard IEC 60947-5-1 Appendix K. |

Contact blocks

Snap action contacts

- Snap action contacts are characterised by different tripping and reset points (differential travel).
- The displacement speed of the moving contacts is not related to the speed of the operator.
- This feature ensures satisfactory electrical performance in applications involving low speed actuators.

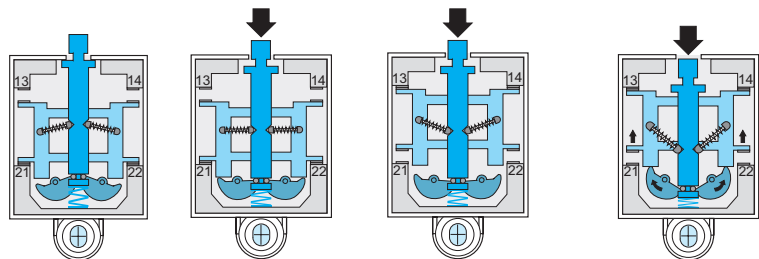

Unactuated state Approach travel Contact change of state Positive opening

Slow break contacts

- Slow break contacts are characterised by identical tripping and resetting points.
 - The displacement speed of the moving contacts is equal, or proportional, to the speed of the operator (which must not be less than 0.1 m/s = 6 m/minute).
- The opening distance is also dependent on the distance travelled by the operator.

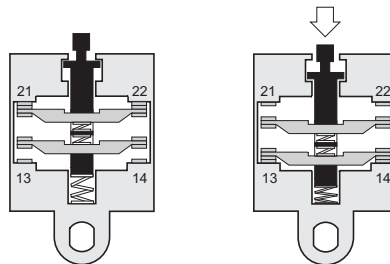

Electrical durability for normal loads

- Normally, for inductive loads, the current value is less than 0.1 A (sealed), i.e. values of 3 to 40 VA sealed and 30 to 1000 VA inrush, depending on the voltage.

For this type of application the electrical durability will exceed 10 million operating cycles.

Application example: XCKJ161 + LC1D12●●● (7 VA sealed, 70 VA inrush).

Electrical durability = 10 million operating cycles.

Switching capacity

- 1 Normal industrial PLC input type 1 (PLC: industrial programmable logic controllers)
- 2 Normal industrial PLC input type 2

3 Switching capacity conforming to IEC 60947-5-5, utilisation category AC-15, DC-13

| | | | | | |
|------|-------|-----|------|-------|-------|
| A300 | 240 V | 3 A | B300 | 240 V | 1.5 A |
|------|-------|-----|------|-------|-------|

| | | | | | |
|------|-------|--------|------|-------|--------|
| Q300 | 250 V | 0.27 A | R300 | 250 V | 0.13 A |
|------|-------|--------|------|-------|--------|

4 Switching capacity conforming to IEC 60947-5-1, utilisation category AC-15, DC-13

| | | | | | |
|------|-------|-----|------|-------|-----|
| A300 | 120 V | 6 A | B300 | 120 V | 3 A |
|------|-------|-----|------|-------|-----|

| | | | | | |
|------|-------|--------|------|-------|--------|
| Q300 | 125 V | 0.55 A | R300 | 125 V | 0.27 A |
|------|-------|--------|------|-------|--------|

Electrical durability for small loads

- The use of limit switches with programmable controllers is becoming more common.

- With small loads, limit switches offer the following levels of reliability:

- failure rate of less than 1 for 100 million operating cycles using snap action contacts (contacts XE2SP),
- failure rate of less than 1 for 20 million operating cycles using slow break contacts (contacts XE●NP and XE3SP).
- failure rate of less than 1 for 5 million operating cycles using contacts XCMD.

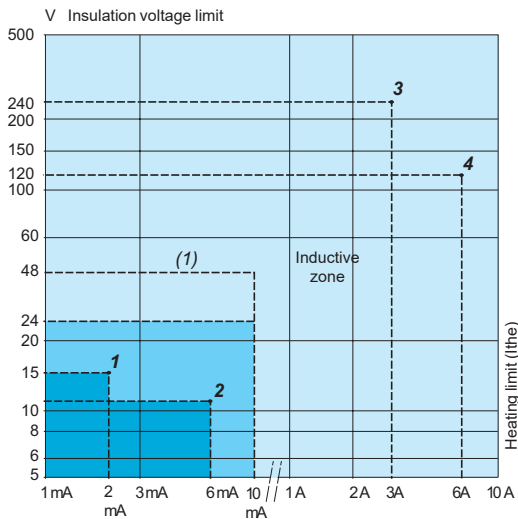

| | | Range of use |
|--|--|---------------------|
| Standard contacts | XE2SP2151, P3151 | [Blue bar] |
| | XE2NP●●●● | |
| Continuous service (frequent switching) | Contacts of XCMD | [Light blue bar] |
| | XE3●P●●●● | |
| Gold flashed contacts on resistive load | Occasional service Infrequent switching, ≤ 1 operating cycle/ day, and/or corrosive atmosphere | (1) [Dark blue bar] |

(1) Usable up to 48 V/10 mA.

Contact blocks (continued)

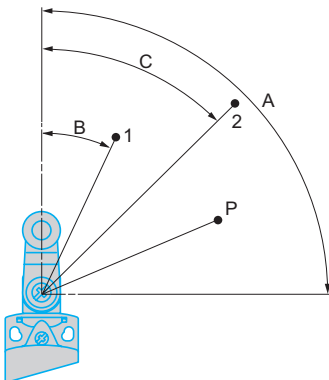
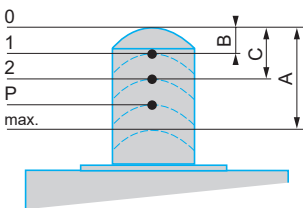
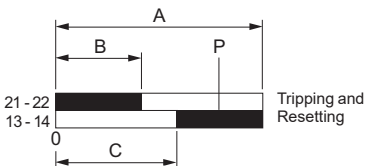
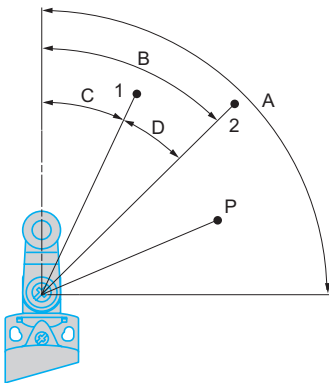
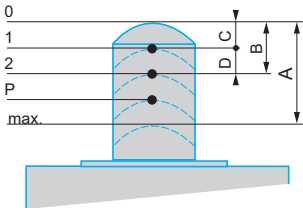
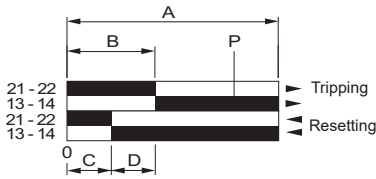

Functional diagrams of snap action contacts

■ Example: NC + NO

- A - Maximum travel of operator in millimetres or degrees.
- B - Tripping travel of contact.
- C - Resetting travel of contact.
- D - Differential travel = B - C.
- P - Point from which positive opening is assured.

□ Linear movement (plunger)

- 1 - Resetting point of contact.
- 2 - Tripping point of contact.
- A - Maximum travel of operator in millimetres.
- B - Tripping travel of contact.
- C - Resetting travel of contact.
- D - Differential travel = B - C.
- P - Point from which positive opening is assured.

□ Rotary movement (lever)

- 1 - Resetting point of contact.
- 2 - Tripping point of contact.
- A - Maximum travel of operator in degrees.
- B - Tripping travel of contact.
- C - Resetting travel of contact.
- D - Differential travel = B - C.
- P - Point from which positive opening is assured.

Functional diagrams of slow break contacts

■ Example: NC + NO break before make

- A - Maximum travel of operator in millimetres or degrees.
- B - Tripping and resetting travel of contact 21-22.
- C - Tripping and resetting travel of contact 13-14.
- P - Point from which positive opening is assured.

□ Linear movement (plunger)

- 1 - Tripping and resetting points of contact 21-22.
- 2 - Tripping and resetting points of contact 13-14.
- A - Maximum travel of operator in millimetres.
- B - Tripping and resetting travel of contact 21-22.
- C - Tripping and resetting travel of contact 13-14.
- P - Positive opening point.

□ Rotary movement (lever)

- 1 - Tripping and resetting points of contact 21-22.
- 2 - Tripping and resetting points of contact 13-14.
- A - Maximum travel of operator in degrees.
- B - Tripping and resetting travel of contact 21-22.
- C - Tripping and resetting travel of contact 13-14.
- P - Positive opening point.

Contact blocks (continued)

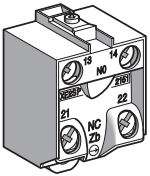

XE2•P screw clamp terminal connections

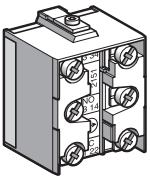

XE3•P screw clamp terminal connections

Mounting

Contact connections

- Tightening torque:
 - minimum tightening torque ensuring the nominal characteristics of the contact: 0.8 N.m,
 - maximum tightening torque without damage to the terminals: 1.2 N.m for XE2•P, 1 N.m for XE3•P.
- Connecting cable: cable preparation lengths:
 - for XE2•P, L = 22 mm,
 - for XE2•P3•••, L = 45 mm,

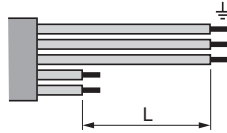

- for XE3•P, L = 14 mm, L1 = 11 mm.

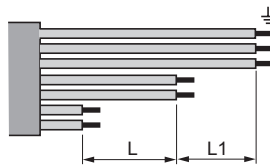

Sweep of connecting cable

- 1 Recommended
- 2 To be avoided

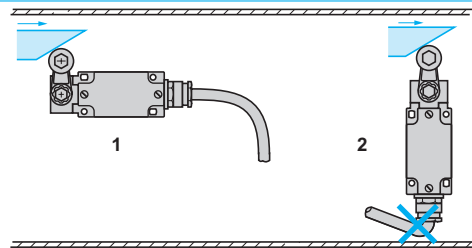

Position of cable gland

- 1 Recommended
- 2 To be avoided

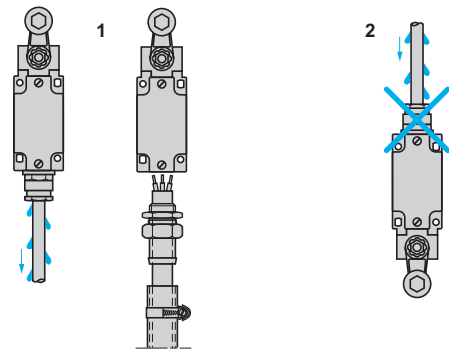

Type of cam

- 1 Recommended
- 2 To be avoided

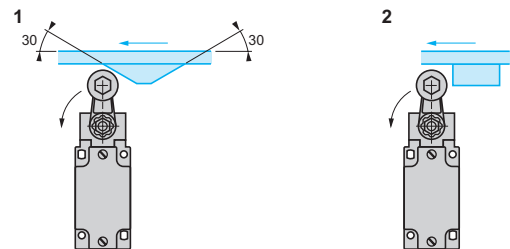

Mounting and fixing limit switches by the head

- 1 Recommended
- 2 Forbidden

XCKD, XCKP, XCKT, XCMD, XCMH and XCMN

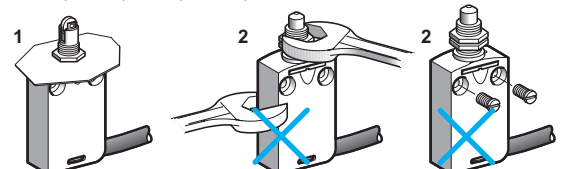

Setting-up

Tightening torque

- The minimum torque is that required to ensure correct operation of the switch.
- The maximum torque is the value which, if exceeded, will damage the switch.

| Range | Item | Torque (N.m) | | Torque (lb-in) | |
|---|--|--------------|------|----------------|-------|
| | | Min. | Max. | Min. | Max. |
| Compact design XCKD, XCKP, XCKT | Cover | 0.8 | 1.2 | 7.08 | 10.62 |
| | Fixing screw for lever on rotary head | 1 | 1.5 | 8.85 | 13.27 |
| Miniature design XCMD, XCMH, XCMN, XCMV | Fixing screw for the product | 1 | 1.5 | 8.85 | 13.27 |
| | Fixing screw for lever on rotary head | 1 | 1.5 | 8.85 | 13.27 |
| Compact design XCKN | Cover | 0.8 | 1.2 | 7.08 | 10.62 |
| | Fixing screw for lever on rotary head | 1 | 1.5 | 8.85 | 13.27 |
| Classic design XCKJ | Cover | 1 | 1.5 | 8.85 | 13.27 |
| | Fixing nut for lever on rotary head | 1 | 1.5 | 8.85 | 13.27 |
| Classic design XCKS | Cover | 0.8 | 1.2 | 7.08 | 10.62 |
| | Fixing nut for lever on rotary head ZCKD | 1 | 1.5 | 8.85 | 13.27 |
| | Fixing nut for lever on rotary head XCKS | 0.8 | 1.2 | 7.08 | 10.62 |
| | Fixing head on body | 0.8 | 1.2 | 7.08 | 10.62 |
| Classic design XCKM, XCKML, XCKL | Cover | 0.8 | 1.2 | 7.08 | 10.62 |
| | Fixing nut for lever on rotary head | 1 | 1.5 | 8.85 | 13.27 |

XCMH, XCMN

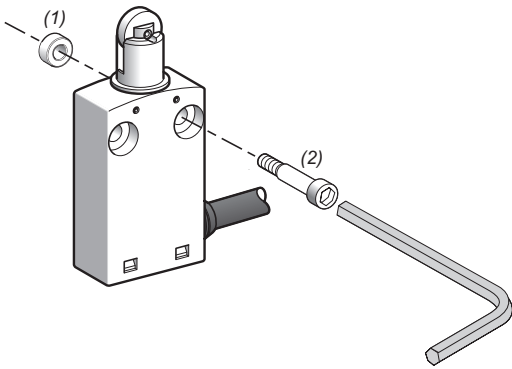

(1) 2 spacers supplied with the switch.
(2) 2 screws Ø 4mm (not included).

XCKD, XCKP, XCKT, XCMD, XCMV

- Adjustable in 3 planes:

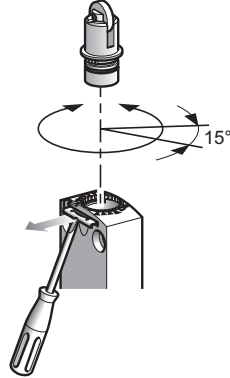

All the heads can be adjusted in 15° steps throughout 360°, in relation to the body.

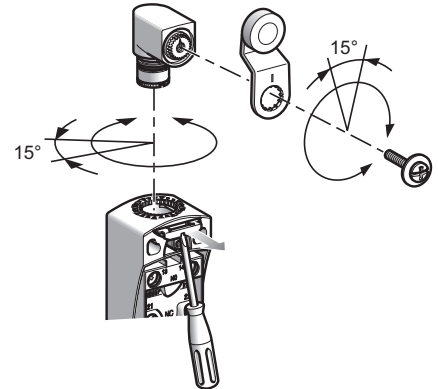

All the levers can be adjusted in 15° steps throughout 360°, in relation to the horizontal axis of the head.

XCKJ

- Adjustable throughout 360° in 5° steps, or in 45° steps by reversing the lever or its mounting.

- 1 Reversed $\alpha = 5^\circ$
- 2 Forward $\alpha = 45^\circ$

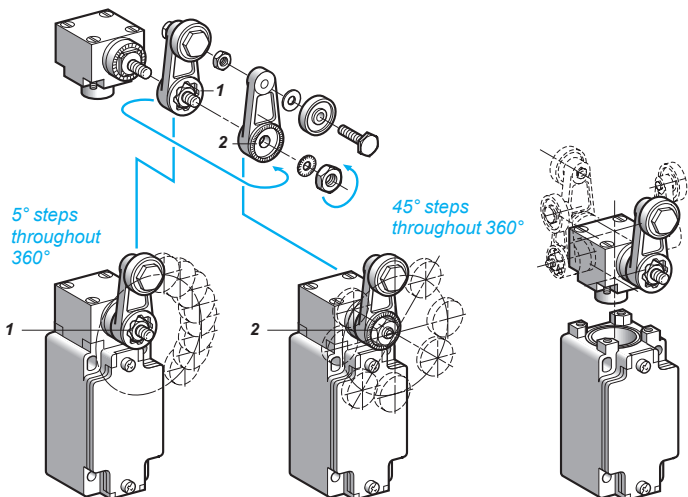

Setting-up (continued)

Direction of actuation programming

■ XC2J

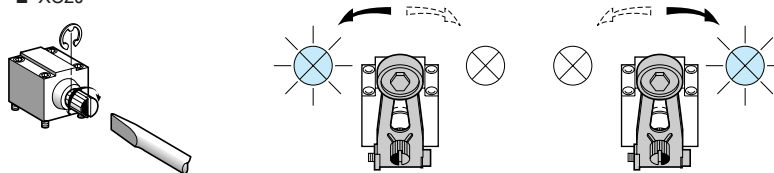

Head ZC2JE05

■ XCKJ

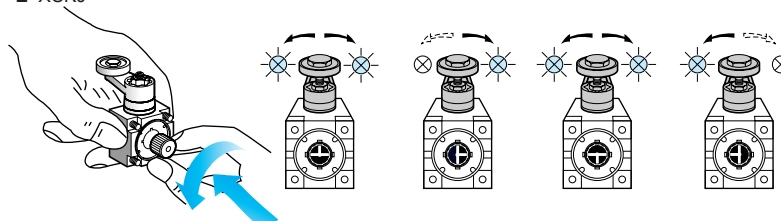

Head ZCKE05

■ XCKS

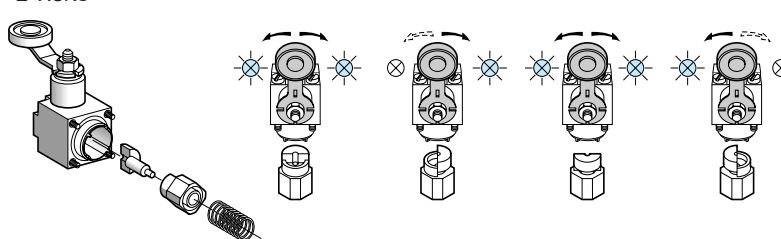

Head ZCKD05

■ XCKD, XCKP, XCKT and XCMD

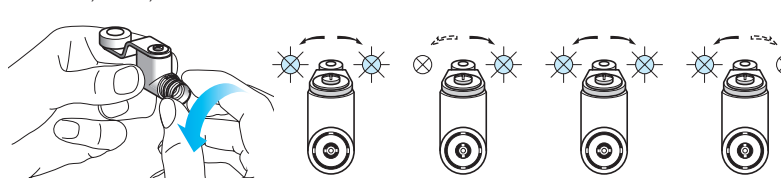

Head ZCE05

Specific cams for heads ZCKE09 and ZC2JE09

- 1 0.5 mm min.
- 2 2 mm min.

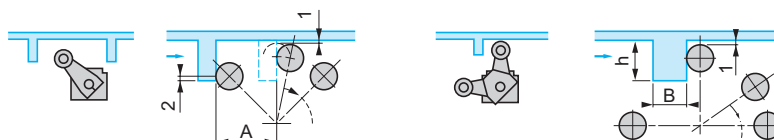

A = length of lever + 11 mm
ZCKE09: $13 < h < 18$ mm and $B = 12$ mm max.
ZC2JE09: $14 < h < 24$ mm and $B = 6$ mm max.

Reminder of the standards

The majority of Telemecanique Sensors products comply to national standards (for example French NF C standards, German DIN standards), European standards (for example CENELEC) or international standards (for example IEC). These standards rigidly stipulate the characteristic requirements of the designated products (for example IEC 60947 relating to low voltage switchgear and control gear). These products, when correctly used, enable the production of control equipment assemblies, machine control equipment or installations conforming to their own specific standards (for example IEC 60204 for the electrical equipment of industrial machines).

IEC 60947-5-1

Insulation coordination (and dielectric strength)

- The standard IEC 60664 defines 4 categories of prospective transient overvoltages. It is important for the user to select control circuit components which are able to withstand these overvoltages. To these ends, the manufacturer states the rated impulse withstand voltage (U imp) applicable to the product.

Terminal connections

- The cabling capacity, mechanical robustness and durability of the terminals, as well as the ability to resist loosening, are verified by standardised tests.
- Terminal reference marking conforms to standard IEC 60947-5-1 Appendix M.

Switching capacity

- With maximum electrical load. A single designation (A300 for example) enables indication of the contact block characteristics related to its utilisation category.

Positive opening operation (IEC 60947-5-1 Appendix K)

- For contacts used in safety applications (end of travel, emergency stop device, etc.) the assurance of positive opening is required (see IEC 60204, EN 60204) after each test, the opening of the contact being verified by testing with an impulse voltage (2500 V).

Electrical symbols for contacts



- Form Za, the 2 contacts (NO + NC) are the same polarity.



- Form Zb, the 2 contacts (NO + NC) are electrically separate.

Symbol for positive opening



- Simplified version



- Complete symbol

CENELEC EN 50047

The European standards organisation CENELEC, which has 14 member countries, has defined in this standard the first type of limit switch.

It defines 4 variants of devices (forms A, B, C, E).
Limit switches XCKP, XCKD and XCKT conform to standard EN 50047.

- (1) Minimum value
- (2) Maximum value

- A: reference axis
- H: differential travel
- P: tripping point
- E: cable entry

Form A, with roller lever

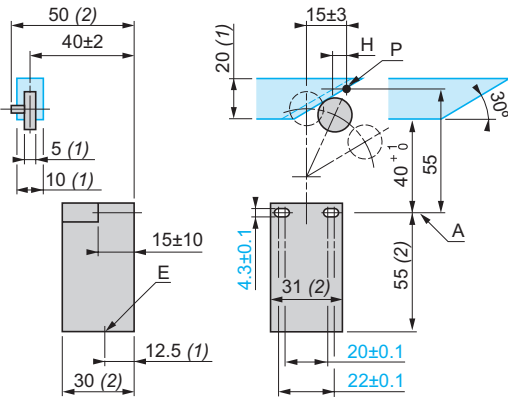

Form B, with end plunger (rounded)

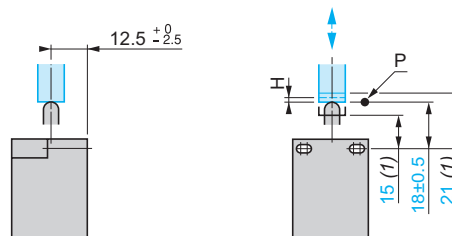

Form C, with end roller plunger

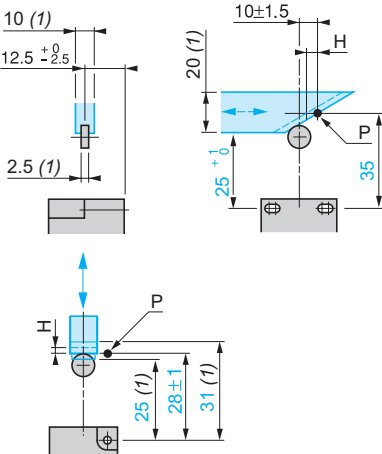

Form E, with roller lever for 1 direction of actuation

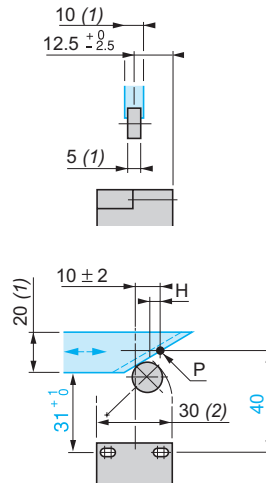

Reminder of the standards (continued)

CENELEC EN 50041

The European standards organisation CENELEC, which has 14 member countries, has defined in this standard the second type of limit switch.

It defines 6 variants of devices (forms A, B, C, D, F, G).
Limit switches XCKJ and XCKS conform to standard EN 50041.

(1) Minimum value
(2) Maximum value

A: reference axis
B: optional elongated holes
H: differential travel
P: tripping point
E: cable entry
Za: tripping zone
Sa: tripping threshold

Form A, with roller lever

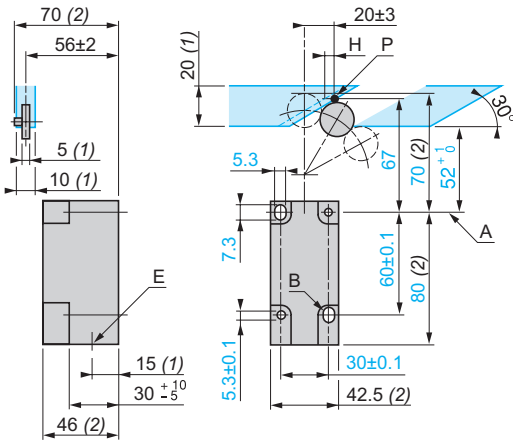

Form B, with end plunger (rounded)

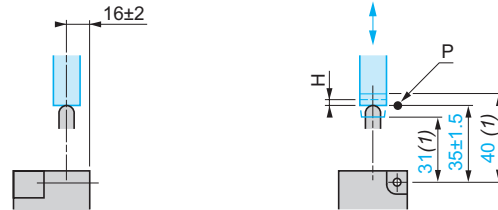

Form C, with end roller plunger

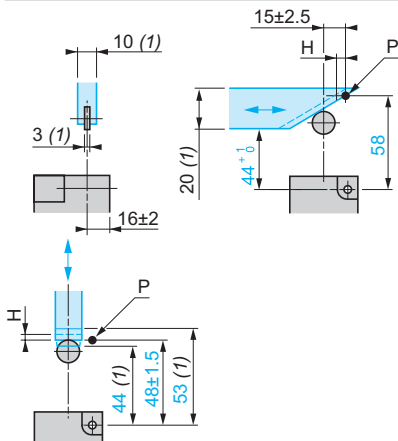

Form D, with rod lever

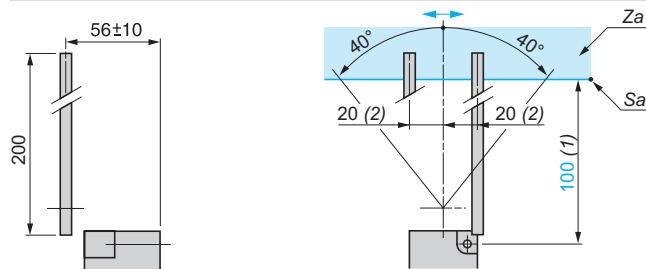

Form F, with side plunger (rounded)

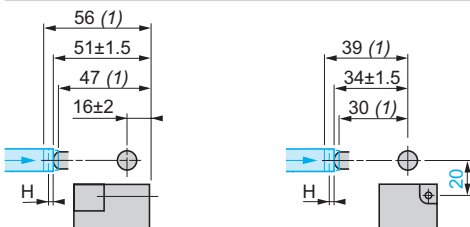

Form G, with side roller plunger

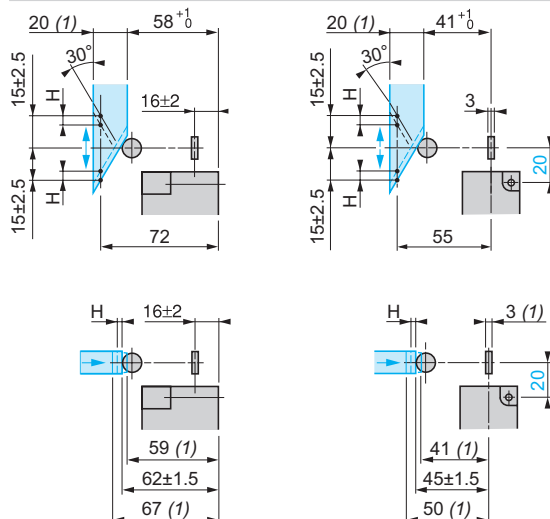

Limit switches

XC Special range

For very severe applications, XC2J

■ XC2J
with 1 cable entry

□ With head for linear movement (plunger)

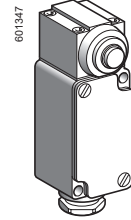
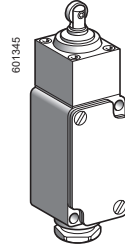
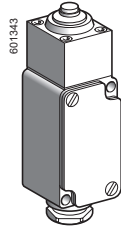

Page 26

□ With head for rotary movement (lever)

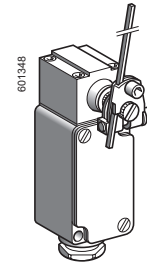
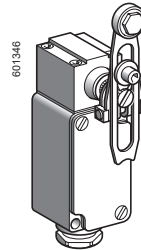
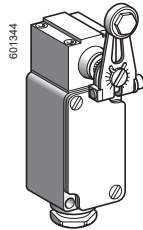

Page 26

Environment characteristics

| | | |
|----------------------------------|--------------------|---|
| Conformity to standards | Products | IEC/EN 60947-5-1, IEC 60337-1, VDE 0660-200, UL 508, CSA C22-2 n° 14 |
| | Machine assemblies | IEC/EN 60204-1, NF C 79-130 |
| Product certifications | Standard version | CSA 300 V ⋮ HD, 60 W ~ |
| | Special version | UL 250 V ~ HD Listed, CSA 300 V ~ HD, 60 W with 1/2" NPT tapped cable entry |
| Protective treatment | Standard version | "TC" |
| Ambient air temperature | For operation | - 25...+ 70°C. Special adaptable sub-assemblies: - 40°C or + 120°C |
| | For storage | - 40...+ 70°C |
| Vibration resistance | | 10 gn (10...500 Hz) conforming to IEC 60068-2-6 |
| Shock resistance | | 25 gn (18 ms) conforming to IEC 60068-2-27 |
| Electric shock protection | | Class I conforming to IEC 60536 and NF C 20-030 |
| Degree of protection | | IP 65 conforming to IEC 60529, IP 657 conforming to NF C 20-010 |
| Repeat accuracy | | 0.01 mm on the tripping points, with 1 million operating cycles for head with end plunger |
| Cable entry | | 1 entry incorporating cable gland. Clamping capacity: 6...13.5 mm |

Contact block characteristics

| | |
|--|--|
| Rated operational characteristics | ~ AC-15; A300 (Ue = 240 V, Ie = 3 A) ⋮ DC-13; Q300 (Ue = 250 V, Ie = 0.27 A), conforming to IEC 60947-5-1 Appendix A, EN 60947-5-1 |
| Rated insulation voltage | 500 V conforming to IEC 60947-5-1, group C conforming to NF C 20-040, 300 V conforming to CSA C22-2 n° 14 |
| Resistance across terminals | ≤ 25 mΩ conforming to NF C 93-050 method A or IEC 60255-7 category 3 |
| Short-circuit protection | 10 A cartridge fuse type gG (gl) |
| Connection | Screw clamp terminals XCKZ01 : clamping capacity, min: 1 x 0.5 mm ² , max: 2 x 2.5 mm ² XESP10•1 : clamping capacity, min: 1 x 0.75 mm ² , max: 2 x 1.5 mm ² |
| Minimum actuation speed | 0.001 m/minute |

- Electrical durability**
- Conforming to IEC 60947-5-1 Appendix C
 - Utilisation categories AC-15 and DC-13
 - Maximum operating rate: 3600 operating cycles/hour
 - Load factor: 0.5

XCKZ01, XESP1021, XESP1031

AC supply
50/60 Hz ~
~ inductive circuit

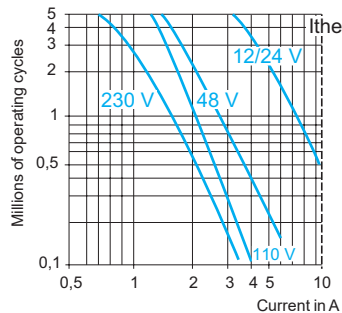

DC supply ⋮

| Voltage V | 24 | 48 | 120 |
|--|----|----|-----|
| Power broken in W for 5 million operating cycles | 10 | 7 | 4 |

Limit switches

XC Special range

For very severe applications, XC2J

Complete switches, fixed body,

1 cable entry incorporating cable gland

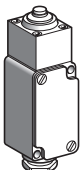
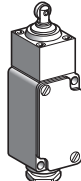
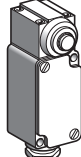
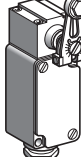
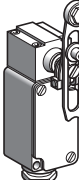
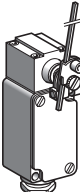

| Type of head | Plunger | | | Rotary | | |
|------------------|---|---|---|--|---|---|
| |  |  |  |  |  |  |
| Type of operator | Metal end plunger | Steel roller plunger | Metal side plunger | Thermoplastic roller lever (1) | Variable length thermoplastic roller lever (1) | Steel rod lever Ø 3 mm (1) |

(1) Adjustable throughout 360°.





References

Single-pole CO
snap action XCKZ01



| | Actuation from left AND right | | | Actuation from left OR right | | |
|-------------------|--|------------------|------------------|------------------------------|----------------------------|----------------------------|
| | ZC2JC1 + ZC2JE61 | ZC2JC1 + ZC2JE62 | ZC2JC1 + ZC2JE63 | ZC2JC1 + ZC2JE01 + ZC2JY11 | ZC2JC1 + ZC2JE01 + ZC2JY31 | ZC2JC1 + ZC2JE01 + ZC2JY51 |
| | | | | | | |
| | | | | Actuation from left OR right | | |
| | | | | ZC2JC1 + ZC2JE05 + ZC2JY11 | ZC2JC1 + ZC2JE05 + ZC2JY31 | ZC2JC1 + ZC2JE05 + ZC2JY51 |
| | | | | | | |
| Weight (kg) | 0.555 | 0.560 | 0.600 | 0.605 | 0.620 | 0.605 |
| Contact operation |  closed  open | | | (A) = cam displacement | | |

Complementary characteristics not shown under general characteristics (page 25)

| Switch actuation | On end | By 30° cam | On end | By 30° cam | By any moving part |
|--|--|---|---|--|---|
| Type of actuation |  |  |  |  |  |
| Maximum actuation speed | 0.5 m/s | | | 1.5 m/s | |
| Mechanical durability (in millions of operating cycles) | 30 | 25 | 30 | | |
| Minimum tripping force or torque | 18 N | | 26 N | With head ZC2JE01: 0.30 N.m With head ZC2JE05: 0.20 N.m | |
| Cable entry | 1 tapped entry incorporating metal cable gland. Clamping capacity 6 to 13.5 mm | | | | |
| Other versions | Switches with gold flashed contacts. Special protective treatments. Please consult our Customer Care Centre. | | | | |

Limit switches

XC Special range

For very severe applications, XC2J

Complete switches, fixed body,

1 cable entry incorporating cable gland

ZC2JC1 + ZC2JE61

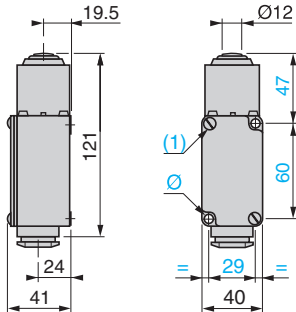

ZC2JC1 + ZC2JE62

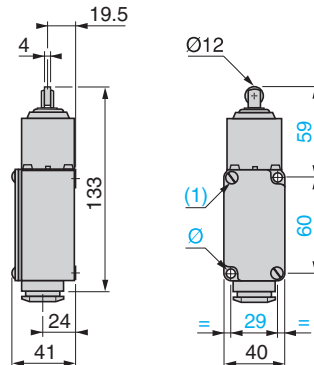

ZC2JC1 + ZC2JE63

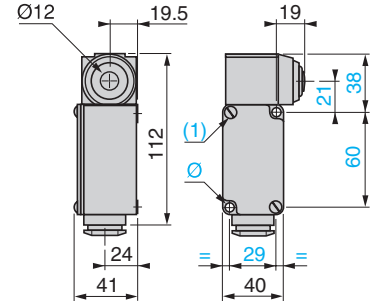

ZC2JC1 + ZC2JE0● + ZC2JY11

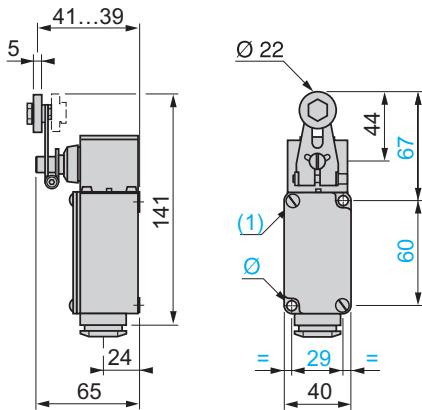

ZC2JC1 + ZC2JE0● + ZC2JY31

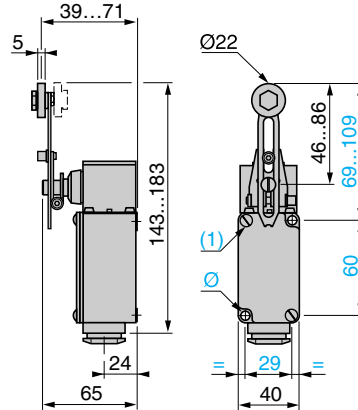

ZC2JC1 + ZC2JE0● + ZC2JY51

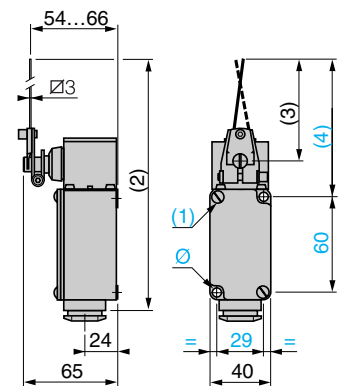

(1) Fixing from the rear: by 2 M5 screws.
Depth of thread on switch: 10 mm.

(2) 222 max.

(3) 125 max.

(4) 148 max.

Ø: Fixing from the front via 2 holes Ø 5.5.

Cable gland incorporated (all XC2JC models).

Limit switches

XC Special range

For very severe applications, XC2J

Fixed or plug-in body

Variable composition

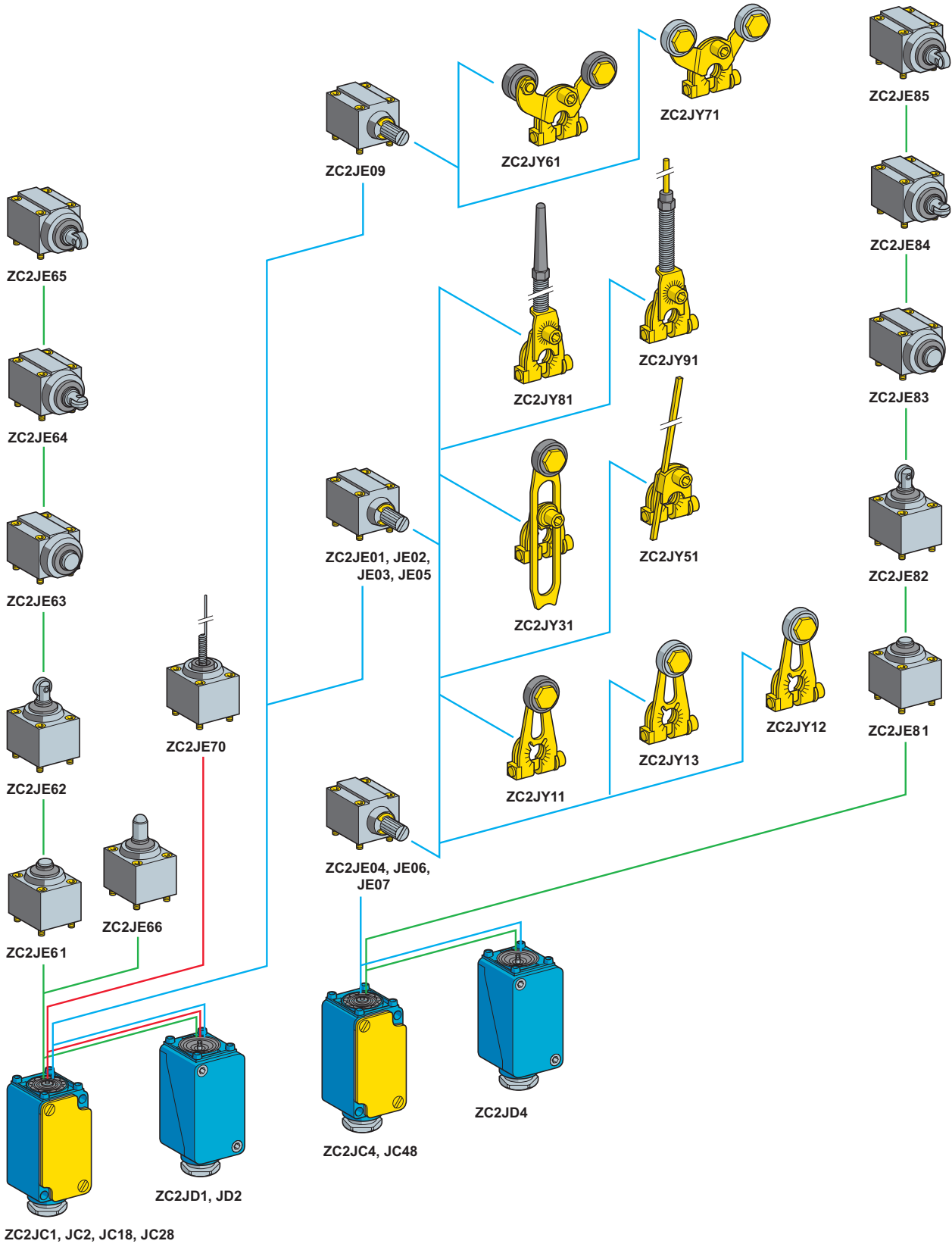

- Plunger head
- Rotary head
- Multi-directional head

Limit switches

XC Special range

For very severe applications, XC2J

Fixed or plug-in body

Adaptable sub-assemblies

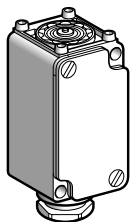

ZC2JC●

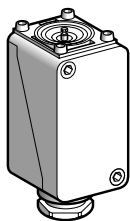

ZC2JD●

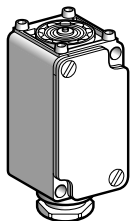

ZC2JC●8

Bodies with contacts for plunger or rotary head

| Type | With contact block | Scheme | Reference | Weight kg |
|---|---|--------|-----------|-----------|
| Fixed bodies (see operation page 34) | | | | |
| 1 step | Single-pole 1 CO snap action (XCKZ01) | | ZC2JC1 | 0.355 |
| | Double-pole 2 CO simultaneous, snap action (XESP1021) | | ZC2JC2 | 0.355 |
| 2 step | Double-pole 2 CO staggered, snap action (XESP1031) | | ZC2JC4 | 0.355 |

Plug-in bodies

| | | | | |
|---|--|--|--------|-------|
| Plug-in bodies (see operation page 34) | | | | |
| 1 step | Single-pole CO snap action | | ZC2JD1 | 0.380 |
| | Double-pole 2 CO simultaneous, snap action | | ZC2JD2 | 0.380 |
| 2 step | Double-pole 2 CO staggered, snap action | | ZC2JD4 | 0.380 |

Bodies incorporating gold flashed contacts, for plunger or rotary head

| Type | With contact block | Scheme | Reference | Weight kg |
|---|---|--------|-----------|-----------|
| Fixed bodies (see operation page 34) | | | | |
| 1 step | Single-pole 1 CO snap action (XCKZ018) | | ZC2JC18 | 0.355 |
| | Double-pole 2 CO simultaneous, snap action (XESP1028) | | ZC2JC28 | 0.360 |
| 2 step | Double-pole 2 CO staggered, snap action (XESP1038) | | ZC2JC48 | 0.360 |

Limit switches

XC Special range

For very severe applications, XC2J

Fixed or plug-in body

Adaptable sub-assemblies

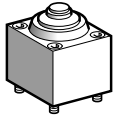

ZC2JE01

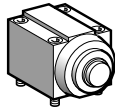

ZC2JE03

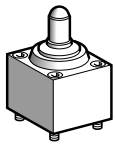

ZC2JE66

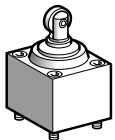

ZC2JE02

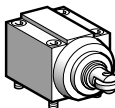

ZC2JE04

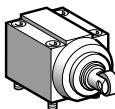

ZC2JE05

Plunger heads

| Type of operator | Compatible bodies | Maximum actuation speed | Reference | Weight kg |
|---|---|-------------------------|-----------|-----------|
| For actuation on end | | | | |
| End plunger metal | ZC2J01 ZC2J02 | 0.5 m/s | ZC2JE61 | 0.195 |
| | ZC2J04 | 0.5 m/s | ZC2JE81 | 0.195 |
| | ZC2J01 ZC2J02 | 0.5 m/s | ZC2JE63 | 0.240 |
| Side plunger metal | ZC2J04 | 0.5 m/s | ZC2JE83 | 0.240 |
| | For actuation by 30° cam | | | |
| End ball bearing plunger | ZC2J01 ZC2J02 | 0.1 m/s | ZC2JE66 | 0.205 |
| | End roller plunger steel | ZC2J01 ZC2J02 | 1 m/s | ZC2JE62 |
| Side plunger with horizontal roller steel | | ZC2J04 | 1 m/s | ZC2JE82 |
| | Side plunger with vertical roller steel | ZC2J01 ZC2J02 | 0.6 m/s | ZC2JE64 |
| Side plunger with vertical roller steel | | ZC2J04 | 0.6 m/s | ZC2JE84 |
| | Side plunger with vertical roller steel | ZC2J01 ZC2J02 | 0.6 m/s | ZC2JE65 |
| Side plunger with vertical roller steel | | ZC2J04 | 0.6 m/s | ZC2JE85 |

Limit switches

XC Special range

For very severe applications, XC2J

Fixed or plug-in body

Adaptable sub-assemblies

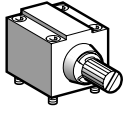

ZC2JE01

Rotary heads (without operating lever)

| Type | Compatible bodies | Maximum actuation speed | Reference | Weight kg |
|--|-------------------|-------------------------|-----------|-----------|
| Spring return (see operation page 34) | | | | |
| Actuation from left AND right | ZC2J●1 ZC2J●2 | 1.5 m/s | ZC2JE01 | 0.210 |
| | ZC2J●4 | 1.5 m/s | ZC2JE04 | 0.210 |
| Actuation from left | ZC2J●1 ZC2J●2 | 1.5 m/s | ZC2JE02 | 0.210 |
| | ZC2J●4 | 1.5 m/s | ZC2JE06 | 0.210 |
| Actuation from right | ZC2J●1 ZC2J●2 | 1.5 m/s | ZC2JE03 | 0.210 |
| | ZC2J●4 | 1.5 m/s | ZC2JE07 | 0.210 |
| Actuation from left OR right (see page 22) | ZC2J●1 ZC2J●2 | 1.5 m/s | ZC2JE05 | 0.210 |

Stay put (see page 22)

| | | | | |
|-------------------------------|------------------|---------|---------|-------|
| Actuation from left AND right | ZC2J●1 ZC2J●2 | 1.5 m/s | ZC2JE09 | 0.210 |
|-------------------------------|------------------|---------|---------|-------|

Multi-directional head (with operator)

| Type of operator | Compatible bodies | Maximum actuation speed | Reference | Weight kg |
|---|-------------------|-------------------------|-----------|-----------|
| For actuation by any moving part (see operation page 34) | | | | |
| "Cat's whisker" | ZC2J●1 ZC2J●2 | 1 m/s in any direction | ZC2JE70 | 0.190 |

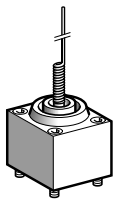

ZC2JE70

Limit switches

XC Special range

For very severe applications, XC2J

Fixed or plug-in body

Adaptable sub-assemblies



ZC2JY1

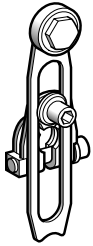

ZC2JY31

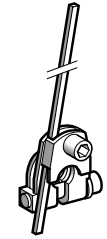

ZC2JY51

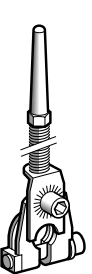

ZC2JY81

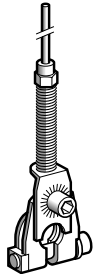

ZC2JY91

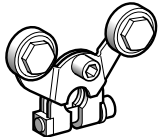

ZC2JY71

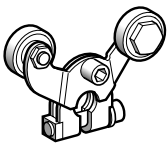

ZC2JY61

Operating levers for rotary heads

| Description | Reference | Weight kg |
|---|--|---------------|
| For actuation by 30° cam | | |
| Roller lever (1) | Thermoplastic | ZC2JY11 0.030 |
| | Steel | ZC2JY13 0.040 |
| | Steel, ball bearing mounted | ZC2JY12 0.040 |
| Variable length roller lever (1) | Thermoplastic | ZC2JY31 0.045 |
| For actuation by any moving part | | |
| Rigid rod lever | Steel \square 3 mm, L = 125 mm (1) | ZC2JY51 0.035 |
| Spring lever (1) | | ZC2JY81 0.040 |
| Spring-rod lever (1) | | ZC2JY91 0.040 |
| For actuation by specific cam (only for operation with head ZC2 JE09, see page 22) | | |
| Forked arm with rollers thermoplastic (1) | 1 track | ZC2JY71 0.055 |
| | 2 track | ZC2JY61 0.055 |
| (1) Adjustable throughout 360° | | |
| Other versions | Other operating levers for rotary heads. Please consult our Customer Care Centre. | |

Limit switches

XC Special range

For very severe applications, XC2J

Fixed or plug-in body

Adaptable sub-assemblies

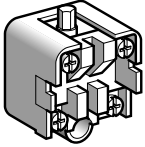

XCKZ01

Contact blocks

| Type of contact | Scheme | For body | Reference | Weight kg |
|---|--------|----------|-----------------|-----------|
| Single-pole 1 CO snap action | | ZC2JC1 | XCKZ01 | 0.050 |
| Double-pole 2 CO simultaneous, snap action | | ZC2JC2 | XESP1021 | 0.045 |
| Double-pole 2 CO staggered, snap action | | ZC2JC4 | XESP1031 | 0.045 |

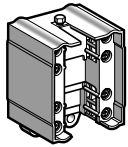

XESP1001

Contact blocks with gold flashed contacts

| Type of contact | Scheme | For body | Reference | Weight kg |
|---|--------|----------|-----------------|-----------|
| Single-pole 1 CO snap action | | ZC2JC18 | XCKZ018 | 0.050 |
| Double-pole 2 CO simultaneous, snap action | | ZC2JC28 | XESP1028 | 0.055 |
| Double-pole 2 CO staggered, snap action | | ZC2JC48 | XESP1038 | 0.055 |

Limit switches

XC Special range

For very severe applications, XC2J

Fixed or plug-in body

Adaptable sub-assemblies

Operation (function diagrams)

Heads ZC2JE61, ZC2JE66 with body

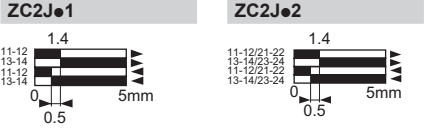

Head ZC2JE62 with body

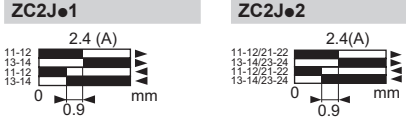

Head ZC2JE63 with body

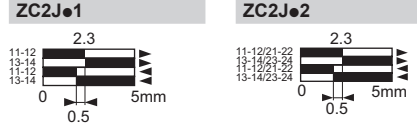

Heads ZC2JE64, ZC2JE65 with body

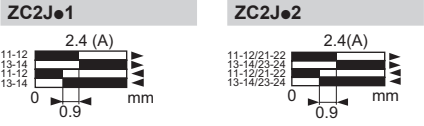

Heads ZC2JE01, ZC2JE02, ZC2JE03, ZC2JE05 with body

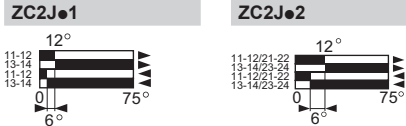

Head ZC2JE09 with body

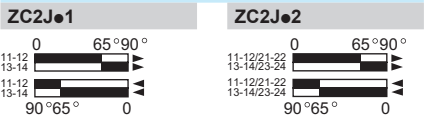

Head ZC2JE70 with body

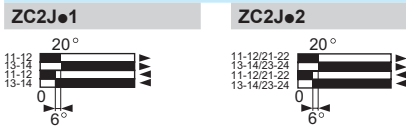

Contact operation

■ closed

□ open

(A) = cam displacement

Heads ZC2JE81, ZC2JE82 with body ZC2J•4

Unactuated

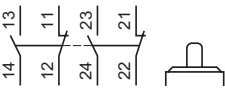

1st step

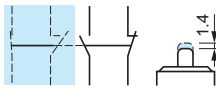

2nd step



Heads ZC2JE83, ZC2JE84, ZC2JE85 with body ZC2J•4

Unactuated

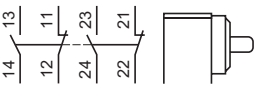

1st step

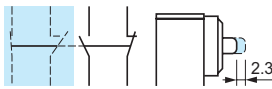

2nd step



Heads ZC2JE04 with body ZC2J•4

Unactuated

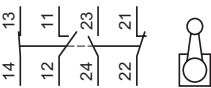

Actuated from left

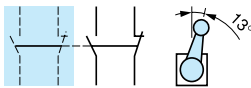

Actuated from right

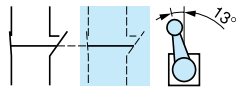

Heads ZC2JE06, ZC2JE07 with body ZC2J•4

Unactuated

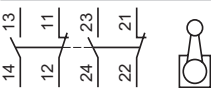

1st step

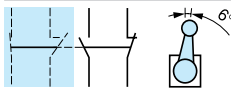

2nd step

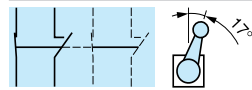

Dimensions

Fixed bodies

ZC2JC1, ZC2JC2, ZC2JC4

Plug-in bodies

ZC2JD1, ZC2JD2, ZC2JD4

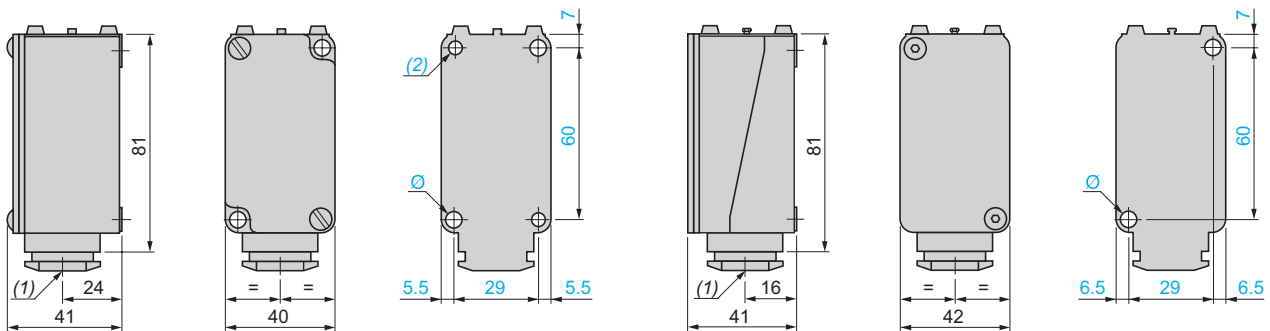

(1) Incorporated cable gland

(2) Fixing from the rear by 2 M5 screws, depth of thread on switch: 10 mm

Ø: Fixing from the front via 2 holes Ø 5.5

(1) Incorporated cable gland

Ø: Fixing from the rear by 2 M6 screws

Fixing from the front via 2 holes Ø 5.5 (remove front part of switch for access)

Limit switches

XC Special range

For very severe applications, XC2J

Fixed or plug-in body

Adaptable sub-assemblies

Plunger heads

ZC2JE61, ZC2JE81

ZC2JE66

ZC2JE62, ZC2JE82

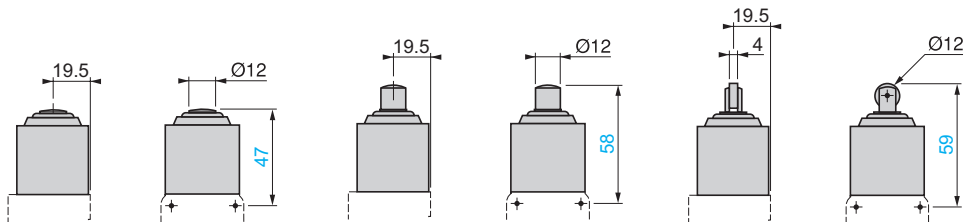

ZC2JE63, ZC2JE83 (2 position)

ZC2JE64, ZC2JE84, ZC2JE65, ZC2JE85 (2 position)

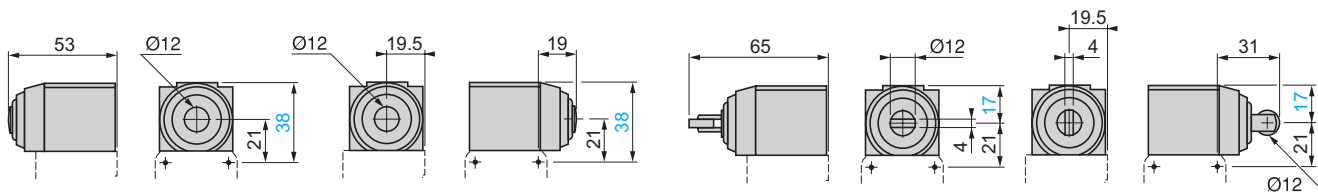

Rotary heads (ZC2JE01 to ZC2JE07) with operating lever

ZC2JY11, ZC2JY12, ZC2JY13

ZC2JY31

ZC2JY51

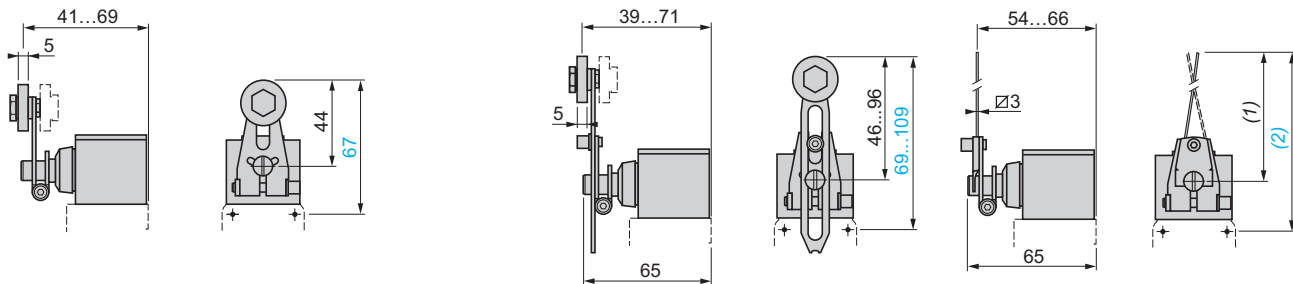

(1) 125 max.

(2) 148 max.

ZC2JY81

ZC2JY91

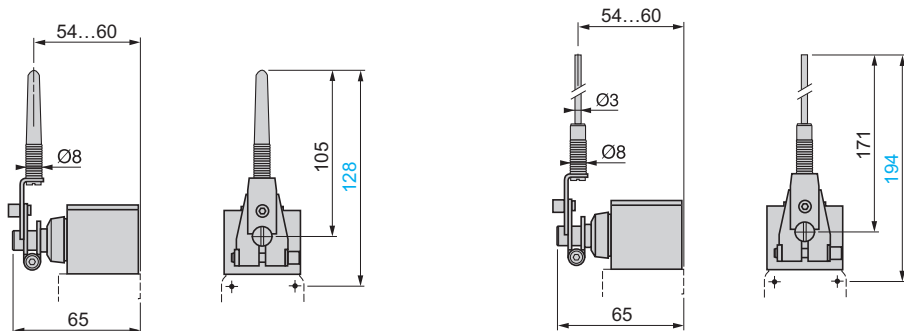

Rotary heads (ZC2JE09) with operating lever

ZC2JY61

ZC2JY71

Multi-directional heads

ZC2JE70

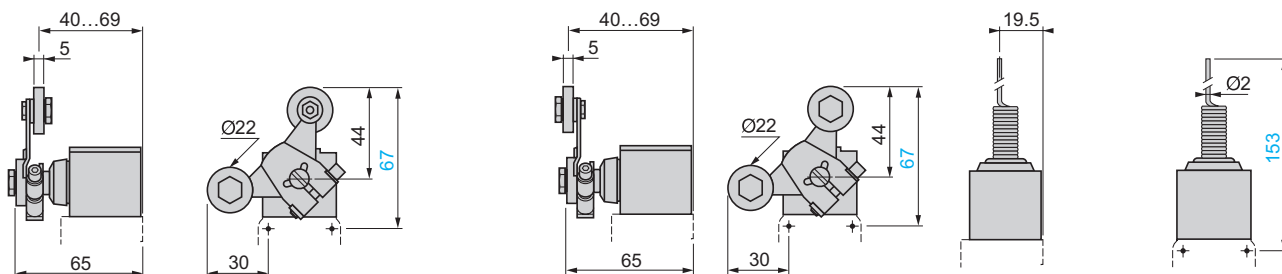

Limit switches

XC Special range

For very severe applications, XC2J

Fixed or plug-in body, adaptable sub-assemblies for low temperature applications (- 40°C)

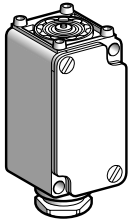

ZC2JC●6

| Bodies with contacts for plunger or rotary head | | | | |
|---|--|--------|-----------|-----------|
| Type | With contact block | Scheme | Reference | Weight kg |
| Fixed bodies | | | | |
| 1 step | Single-pole 1 CO snap action (XCK Z01) | | ZC2JC16 | 0.355 |
| | Double-pole 2 CO simultaneous, snap action (XES P1021) | | ZC2JC26 | 0.355 |
| 2 step | Double-pole 2 CO staggered, snap action (XES P1031) | | ZC2JC46 | 0.355 |

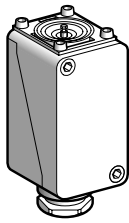

ZC2JD●6

| Plug-in bodies | | | | |
|----------------|--|--------|-----------|-----------|
| Type | With contact block | Scheme | Reference | Weight kg |
| 1 step | Single-pole CO snap action | | ZC2JD16 | 0.380 |
| | Double-pole 2 CO simultaneous, snap action | | ZC2JD26 | 0.380 |
| 2 step | Double-pole 2 CO staggered, snap action | | ZC2JD46 | 0.380 |

Plunger heads

| Type of operator | Compatible bodies | Maximum actuation speed | Reference | Weight kg |
|---|-------------------|-------------------------|-----------|-----------|
| For actuation on end | | | | |
| End plunger metal | ZC2J●16 | 0.5 m/s | ZC2JE616 | 0.195 |
| | ZC2J●26 | | | |
| | ZC2J●46 | 0.5 m/s | ZC2JE816 | 0.195 |
| Side plunger metal | ZC2J●16 | 0.5 m/s | ZC2JE636 | 0.240 |
| | ZC2J●26 | | | |
| | ZC2J●46 | 0.5 m/s | ZC2JE836 | 0.240 |
| For actuation by 30° cam | | | | |
| End ball bearing plunger | ZC2J●16 | 0.1 m/s | ZC2JE666 | 0.205 |
| | ZC2J●26 | | | |
| End roller plunger steel | ZC2J●16 | 1 m/s | ZC2JE626 | 0.200 |
| | ZC2J●26 | | | |
| | ZC2J●46 | 1 m/s | ZC2JE826 | 0.200 |
| Side plunger with horizontal roller steel | ZC2J●16 | 0.6 m/s | ZC2JE646 | 0.245 |
| | ZC2J●26 | | | |
| | ZC2J●46 | 0.6 m/s | ZC2JE846 | 0.245 |
| Side plunger with vertical roller steel | ZC2J●16 | 0.6 m/s | ZC2JE656 | 0.245 |
| | ZC2J●26 | | | |
| | ZC2J●46 | 0.6 m/s | ZC2JE856 | 0.245 |

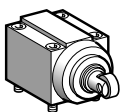

ZC2JE●56

Limit switches

XC Special range

For very severe applications, XC2J

Fixed or plug-in body, adaptable sub-assemblies for low temperature applications (- 40°C)

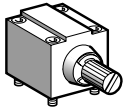

ZC2JE06

Rotary heads (without operating lever)

| Type | Compatible bodies | Maximum actuation speed | Reference | Weight kg |
|--|--------------------|-------------------------|-----------------|-----------|
| Spring return | | | | |
| Actuation from left AND right | ZC2J●16 ZC2J●26 | 1.5 m/s | ZC2JE016 | 0.210 |
| | ZC2J●46 | 1.5 m/s | ZC2JE046 | 0.210 |
| Actuation from left | ZC2J●16 ZC2J●26 | 1.5 m/s | ZC2JE026 | 0.210 |
| | ZC2J●46 | 1.5 m/s | ZC2JE066 | 0.210 |
| Actuation from right | ZC2J●16 ZC2J●26 | 1.5 m/s | ZC2JE036 | 0.210 |
| | ZC2J●46 | 1.5 m/s | ZC2JE076 | 0.210 |
| Actuation from left OR right (see page 22) | ZC2J●16 ZC2J●26 | 1.5 m/s | ZC2JE056 | 0.210 |
| Stay put (see page 22) | | | | |
| Actuation from left AND right | ZC2J●16 ZC2J●26 | 1.5 m/s | ZC2JE096 | 0.210 |

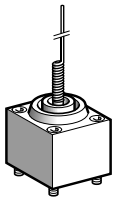

ZC2JE706

Multi-directional head (with operator)

| Type of operator | Compatible bodies | Maximum actuation speed | Reference | Weight kg |
|---|--------------------|-------------------------|-----------------|-----------|
| For actuation by any moving part | | | | |
| "Cat's whisker" | ZC2J●16 ZC2J●26 | 1 m/s in any direction | ZC2JE706 | 0.190 |

Limit switches

XC Special range

For very severe applications, XC2J

Fixed or plug-in body, adaptable sub-assemblies for low temperature applications (- 40°C)



ZC2JY1

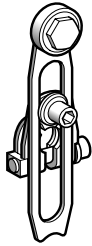

ZC2JY31

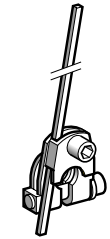

ZC2JY51

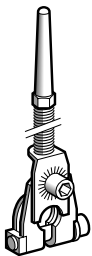

ZC2JY81

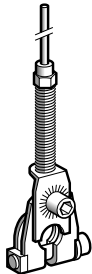

ZC2JY91

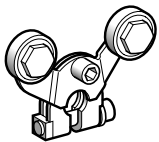

ZC2JY71

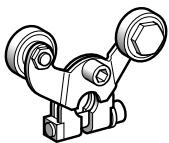

ZC2JY61

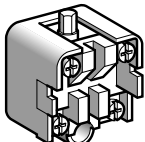

XCKZ01

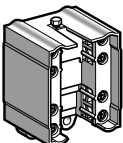

XESP10

Operating levers for rotary heads

| Description | Reference | Weight kg |
|----------------------------------|-----------------------------|---------------|
| For actuation by 30° cam | | |
| Roller lever (1) | Thermoplastic | ZC2JY11 0.030 |
| | Steel | ZC2JY13 0.040 |
| | Steel, ball bearing mounted | ZC2JY12 0.040 |
| Variable length roller lever (1) | Thermoplastic | ZC2JY31 0.045 |

For actuation by any moving part

| | | |
|----------------------|--------------------------------------|---------------|
| Rigid rod lever | Steel \square 3 mm, L = 125 mm (1) | ZC2JY51 0.035 |
| Spring lever (1) | | ZC2JY81 0.040 |
| Spring-rod lever (1) | | ZC2JY91 0.040 |

For actuation by specific cam (only for operation with head ZC2 JE096, see page 22)

| | | |
|---|---------|---------------|
| Forked arm with rollers thermoplastic (1) | 1 track | ZC2JY71 0.055 |
| | 2 track | ZC2JY61 0.055 |

Contact blocks

| Type of contact | Scheme | For body | Reference | Weight kg |
|--|--------|----------|-----------|-----------|
| Single-pole 1 CO snap action | | ZC2JC16 | XCKZ01 | 0.050 |
| Double-pole 2 CO simultaneous, snap action | | ZC2JC26 | XESP1021 | 0.045 |
| Double-pole 2 CO staggered, snap action | | ZC2JC46 | XESP1031 | 0.045 |

(1) Adjustable throughout 360°

Other versions

Other operating levers for rotary heads. Please consult our Customer Care Centre.

Limit switches

XC Special range

For very severe applications, XC2J

Fixed body, adaptable sub-assemblies for high temperature applications (+ 120°C)

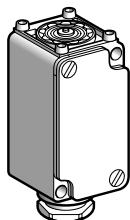

ZC2JC5

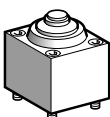

ZC2JE15

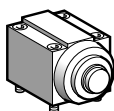

ZC2JE35

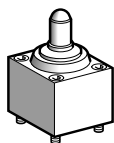

ZC2JE665

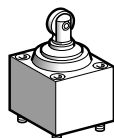

ZC2JE25

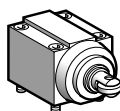

ZC2JE45

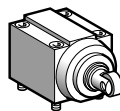

ZC2JE55

Bodies with contacts for plunger or rotary head

| Type | With contact block | Scheme | Reference | Weight kg |
|---------------------|---|--------|-----------|-----------|
| Fixed bodies | | | | |
| 1 step | Single-pole 1 CO snap action (XCK Z015) | | ZC2JC15 | 0.355 |
| | Double-pole 2 CO simultaneous, snap action (XES P10215) | | ZC2JC25 | 0.355 |
| 2 step | Double-pole 2 CO staggered, snap action (XES P10315) | | ZC2JC45 | 0.355 |

Plunger heads

| Type of operator | Compatible bodies | Maximum actuation speed | Reference | Weight kg |
|---|--------------------|-------------------------|-----------|-----------|
| For actuation on end | | | | |
| End plunger metal | ZC2JC15 ZC2JC25 | 0.5 m/s | ZC2JE615 | 0.195 |
| | ZC2JC45 | 0.5 m/s | ZC2JE815 | 0.195 |
| Side plunger metal | ZC2JC15 ZC2JC25 | 0.5 m/s | ZC2JE635 | 0.240 |
| | ZC2JC45 | 0.5 m/s | ZC2JE835 | 0.240 |
| For actuation by 30° cam | | | | |
| End ball bearing plunger | ZC2JC15 ZC2JC25 | 0.1 m/s | ZC2JE665 | 0.205 |
| End roller plunger steel | ZC2JC15 ZC2JC25 | 1 m/s | ZC2JE625 | 0.200 |
| | ZC2JC45 | 1 m/s | ZC2JE825 | 0.200 |
| Side plunger with horizontal roller steel | ZC2JC15 ZC2JC25 | 0.6 m/s | ZC2JE645 | 0.245 |
| | ZC2JC45 | 0.6 m/s | ZC2JE845 | 0.245 |
| Side plunger with vertical roller steel | ZC2JC15 ZC2JC25 | 0.6 m/s | ZC2JE655 | 0.245 |
| | ZC2JC45 | 0.6 m/s | ZC2JE855 | 0.245 |

Limit switches

XC Special range

For very severe applications, XC2J
Fixed body, adaptable sub-assemblies for high
temperature applications (+ 120°C)

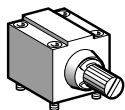

ZC2JE05

Rotary heads (without operating lever)

| Type | Compatible bodies | Maximum actuation speed | Reference | Weight kg |
|-------------------------------|--------------------|-------------------------|-----------------|-----------|
| Spring return | | | | |
| Actuation from left AND right | ZC2JC15 ZC2JC25 | 1.5 m/s | ZC2JE015 | 0.210 |
| | ZC2JC45 | 1.5 m/s | ZC2JE045 | 0.210 |
| Actuation from left | ZC2JC15 ZC2JC25 | 1.5 m/s | ZC2JE025 | 0.210 |
| | ZC2JC45 | 1.5 m/s | ZC2JE065 | 0.210 |
| Actuation from right | ZC2JC15 ZC2JC25 | 1.5 m/s | ZC2JE035 | 0.210 |
| | ZC2JC45 | 1.5 m/s | ZC2JE075 | 0.210 |

Stay put (see page 22)

| | | | | |
|-------------------------------|--------------------|---------|-----------------|-------|
| Actuation from left AND right | ZC2JC15 ZC2JC25 | 1.5 m/s | ZC2JE095 | 0.210 |
|-------------------------------|--------------------|---------|-----------------|-------|

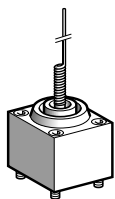

ZC2JE705

Multi-directional head (with operator)

| Type of operator | Compatible bodies | Maximum actuation speed | Reference | Weight kg |
|---|--------------------|-------------------------|-----------------|-----------|
| For actuation by any moving part | | | | |
| "Cat's whisker" | ZC2JC15 ZC2JC25 | 1 m/s in any direction | ZC2JE705 | 0.190 |

Limit switches

XC Special range

For very severe applications, XC2J
Fixed body, adaptable sub-assemblies for high temperature applications (+ 120°C)



ZC2JY1



ZC2JY51

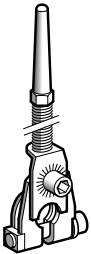

ZC2JY815

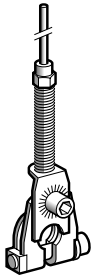

ZC2JY915

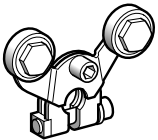

ZC2JY715

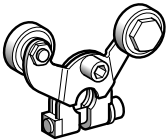

ZC2JY615

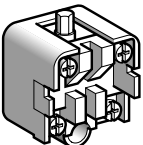

XCKZ015

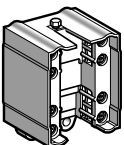

XESP10

Operating levers for rotary heads

| Description | | Reference | Weight kg |
|---|--|-----------|-----------|
| For actuation by 30° cam | | | |
| Roller lever (1) | Thermoplastic | ZC2JY115 | 0.030 |
| | Steel | ZC2JY13 | 0.040 |
| | Steel, ball bearing mounted | ZC2JY12 | 0.040 |
| Offset roller lever (1) | Thermoplastic | ZC2JY215 | 0.035 |
| Variable length roller lever (1) | Thermoplastic | ZC2JY315 | 0.035 |
| Variable length offset roller lever (1) | Thermoplastic | ZC2JY415 | 0.040 |
| For actuation by any moving part | | | |
| Rigid rod lever | Steel \varnothing 3 mm, L = 125 mm (1) | ZC2JY51 | 0.035 |
| Spring lever (1) | | ZC2JY815 | 0.040 |
| Spring-rod lever (1) | | ZC2JY915 | 0.040 |

For actuation by specific cam (only for operation with head ZC2JE095, see page 22)

| | | | |
|---|---------|----------|-------|
| Forked arm with rollers thermoplastic (1) | 1 track | ZC2JY715 | 0.055 |
| | 2 track | ZC2JY615 | 0.055 |

Contact blocks

| Type of contact | Scheme | For body | Reference | Weight kg |
|--|--------|----------|-----------|-----------|
| Single-pole 1 CO snap action | | ZC2JC15 | XCKZ015 | 0.050 |
| Double-pole 2 CO simultaneous, snap action | | ZC2JC25 | XESP10215 | 0.045 |
| Double-pole 2 CO staggered, snap action | | ZC2JC45 | XESP10315 | 0.045 |

(1) Adjustable throughout 360°

Other versions

Other operating levers for rotary heads.
Please consult our Customer Care Centre.

Limit switches

XC Special range

For hoisting and material handling applications, XCR

■ XCR

□ With head for rotary movement operators, spring return to off position

1 contact actuation position per direction

562248

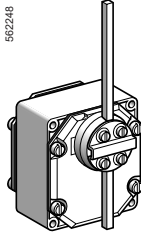

562249

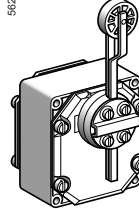

562250

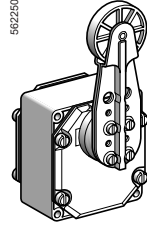

Page 46

□ With head for rotary movement operators, stay put

1 contact actuation position per direction

562251

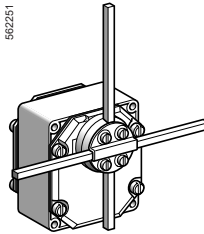

Page 46

Limit switches

XC Special range

For hoisting and material handling applications, XCKMR and XCKVR

For conveyor belt shift monitoring applications, XCRT

■ XCKMR (metal)

□ With head for rotary movement operators, stay put

4 mechanical actuation positions of 4 contacts
From 2 to 5 electrical positions depending on model

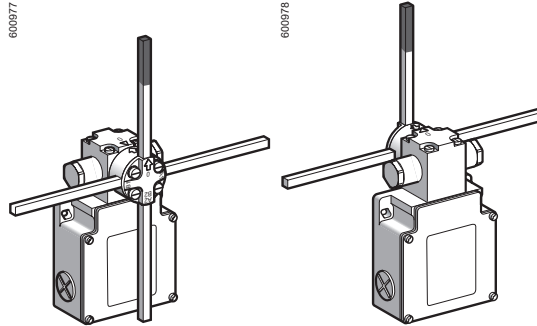

Page 52

■ XCKVR (plastic)

□ With head for rotary movement operators, stay put

4 mechanical actuation positions of 4 contacts
From 2 to 5 electrical positions depending on model

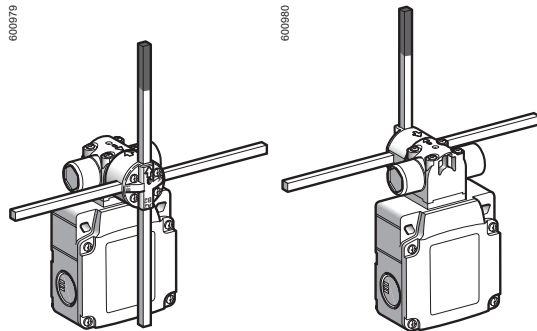

Page 52

■ XCRT

□ With head for rotary movement operators, spring return to off position

2 contact actuation positions per direction
1 contact actuated at 10°, other contact at 18°

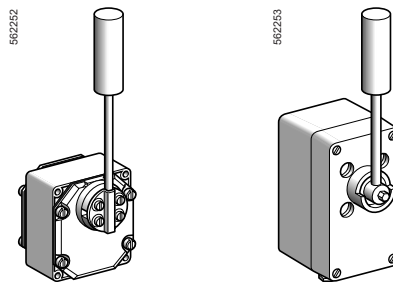

Page 48

Limit switches

XC Special range

For hoisting and material handling applications, XCR, XCKMR and XCKVR

For conveyor belt shift monitoring applications, XCRT

| Environment characteristics | | | | |
|---|---|---|---|--|
| Limit switches | | XCR and XCRT | XCKMR (metal) | XCKVR (plastic) |
| Conformity to standards | Products | EN/IEC 60947-5-1, CSA C22-2 n° 14, CCC | EN/IEC 60947-5-1, CSA C22-2 n° 14, UL 508, CCC | |
| | Machine assemblies | EN/IEC 60204-1 | | |
| Product certifications | | XCRA, B, E, F: CE, CSA, UL, CCC, EAC | CE, UL, CSA, CCC, EAC | |
| Protective treatment | Standard version | "TC" | | |
| Ambient air temperature | For operation | - 25...+ 70 °C | - 25...+ 70 °C | - 25...+ 70 °C |
| | For storage | - 40...+ 70 °C | - 40...+ 85 °C | - 40...+ 70 °C |
| Vibration resistance | Conforming to EN/IEC 60068-2-6 | 9 gn (10...500 Hz) | 25 gn (10...500 Hz) | 25 gn (10...500 Hz) |
| Shock resistance | Conforming to EN/IEC 60068-2-27 | XCRA, B, E, F: 68 gn, XCRT: 30 gn (18 ms) | 50 gn | 50 gn |
| Electric shock protection | | Class I conforming to IEC 60536 | | Class II conforming to IEC 60536 |
| Degree of protection | Conforming to EN/IEC 60529 | XCRA, B, E, F: IP 65, XCRT: IP 65 | IP 66 | IP 65 |
| Degree of protection against mechanical impacts | Conforming to IEC 62262 | IK 07 | IK 07 | IK 04 |
| Materials | Enclosure | Metal (except XCRT315: polyester) | Zamak ZP3 | (PBT + PC) - GF 30 FR (Valox) |
| | Cover | Metal (except XCRT315: polyester) | DC03 steel | (PBT + PC) - GF 30 FR (Valox) |
| | Head | Metal | Zamak ZP3 | (PBT + PC) - GF 30 FR (Valox) |
| Cable entry | | 1 tapped entry for Pg 13.5 cable gland | 3 tapped entries for Pg 13.5 cable gland or tapped M20 x 1.5 | 1 tapped entry M20 x 1.5. 2 breakout holes for ISO M20 cable gland |
| Contact block characteristics | | | | |
| Rated operational characteristics | Conforming to EN/IEC 60947-5-1 Appendix A | XCRA, B, E, F: ~ AC-15; A300 (Ue = 240 V, Ie = 3 A), Ithe = 10 A --- DC-13 ; Q300 (Ue = 250 V, Ie = 0.27 A) XCRT: ~ AC-15; B300 (Ue = 240 V, Ie = 1.5 A/ Ue = 120 V, Ie = 3 A) --- DC-13 ; R300 (Ue = 250 V, Ie = 0.1 A) | ~ AC-15 ; A300 (Ue = 240 V, Ie = 3 A), Ithe = 10 A --- DC-13 ; Q150 (Ue = 125 V, Ie = 0.55 A) | |
| Rated insulation voltage | | Ui = 500 V degree of pollution 3 conforming to EN/IEC 60947-1 Ui = 300 V conforming to UL 508, CSA C22-2 n° 14 | | |
| Rated impulse withstand voltage | | U imp = 6 kV conforming to EN/IEC 60947-1, IEC 60664 | | |
| Positive operation (depending on model) | | NC contacts with positive opening operation conforming to EN/IEC 60947-5-1 Section 3 (except XCRT) | NC contacts with positive opening operation conforming to EN/IEC 60947-5-1 Section 3 (contacts 21-22) | |
| Resistance across terminals | | ≤ 25 m Ω conforming to NF C 93-050 method A or IEC 60255-7 category 3 | | |
| Short-circuit protection | | 10 A cartridge fuse type gG (gl) | | |
| Connection | Screw clamp terminals | Clamping capacity XE2N P2151 ou XCRT: min: 1 x 0.5 mm ² , max: 2 x 2.5 mm ² XE2S P2151: min: 1 x 0.34 mm ² , max: 2 x 1.5 mm ² | Clamping capacity min: 1 x 0.5 mm ² max: 2 x 2.5 mm ² | |
| Minimum actuation speed | | XE2SP2151 or XCRT: 0.01 m/mn | XE2NP2151 or XCKMR and XCKVR : 6 m/mn | |

Limit switches

XC Special range

For hoisting and material handling applications, XCR, XCKMR and XCKVR

For conveyor belt shift monitoring applications, XCRT

Contact block characteristics (continued)

Electrical durability

- Conforming to EN/IEC 60947-5-1 Appendix C
- Utilisation categories AC-15 and DC-13
- Maximum operating rate: 3600 operating cycles/hour
- Load factor: 0.5

AC supply
~ 50/60 Hz
~ inductive circuit

XE2SP2151

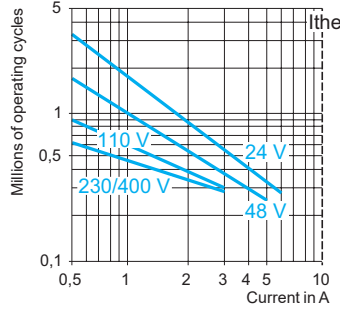

XE2NP2151

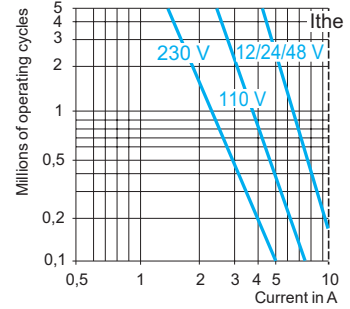

XCRT contacts

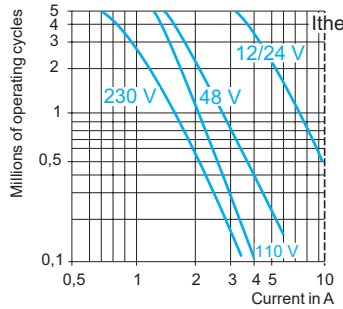

DC supply ---

| | Voltage V | 24 | 48 | 120 |
|--|----------------------|----|----|-----|
| Power broken in W for 5 million operating cycles | XE2SP2151 | 10 | 7 | 4 |
| | XE2NP2151 | 13 | 9 | 7 |
| | XCRT contacts | 10 | 7 | 4 |

For XE2SP2151 on ~ or --- NC and NO contacts simultaneously loaded to the values shown with reverse polarity.

Limit switches

XC Special range

For hoisting and material handling applications, XCR
Complete switches with 1 cable entry

| | | |
|----------------------|---|-----------------------|
| Type of head | Rotary with spring return to off position | Stay put |
| Maximum displacement | 55° in each direction | 90° in each direction |

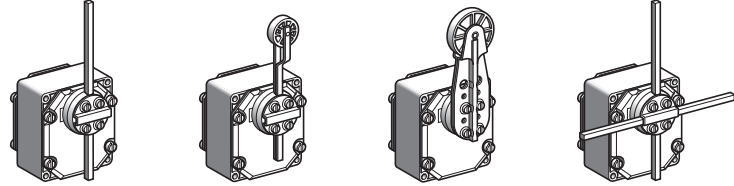

| | | | | |
|------------------|-------------------------------|----------------------------|----------------------------------|---|
| Type of operator | Metal rod, \varnothing 6 mm | Thermoplastic roller lever | Large thermoplastic roller lever | Metal rods, \varnothing 6 mm, crossed rods for XCRE●●, "T" rods for XCRF●●7 |
| Rod length | 1 rod of 200 mm | — | — | XCRE●●: 2 rods of 200 mm XCRF●●: 1 rod of 200 mm and 1 rod of 300 mm |

References of complete switches (⊖ NC contact with positive opening operation)

| | | | | | |
|---|--|-------------------------|-------------------------|-------------------------|-----------------------------|
| Two 2-pole NC + NO snap action XE2SP2151 1 st contact 2 nd contact | Both contacts operate in each direction | XCRA11 ⊖ (3) | XCRA12 ⊖ (3) | XCRA15 ⊖ (3) | XCRE18 ⊖ (3) (4) |
| | 1 contact operates in each direction | XCRB11 ⊖ (3) | XCRB12 ⊖ (3) | XCRB15 ⊖ (3) | XCRF17 ⊖ (3) |
| Two 2-pole NC + NO break before make, slow break XE2NP2151 1 st contact 2 nd contact | Both contacts operate in each direction | XCRA51 ⊖ (3) | XCRA52 ⊖ (3) | XCRA55 ⊖ (3) | XCRE58 ⊖ (3) (4) |
| | 1 contact operates in each direction | XCRB51 ⊖ (3) | XCRB52 ⊖ (3) | XCRB55 ⊖ (3) | XCRF57 ⊖ (3) |
| Weight (kg) | 1.110 | 1.145 | 1.155 | 1.135 | |
| Contact operation | ■ closed (P) = positive opening point □ open (1) 1 st contact (2) 2 nd contact | | | | |

Complementary characteristics

| | |
|--------------------------------------|--|
| Lever maximum actuation speed | 1.5 m/s |
| Mechanical durability | 10 million operating cycles |
| Minimum torque | For tripping: 0.45 N.m For positive opening: 0.75 N.m |
| Cable entry | 1 entry tapped for Pg 13.5 cable gland conforming to NF C 68-300 (DIN Pg 13.5) Clamping capacity 9 to 12 mm |

(3) For a limit switch with watertight reinforced seal (IP 65), add 1 to the end of the reference.
Example: XCRF17 becomes XCRF171.
(4) For XCRE18 and XCRE58, the rotation is not limited.

Limit switches

XC Special range

For hoisting and material handling applications, XCR

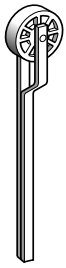

XCRZ02

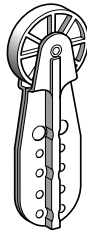

XCRZ05

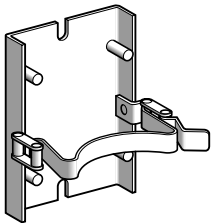

XCRZ09

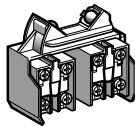

XCRZ11

Separate components

| Description | For switches | Type | Reference | Weight kg |
|---|------------------------------|---|---------------|-----------|
| Rod, \varnothing 6 mm | XCRA XCRB XCRE XCRF | L = 200 mm | XCRZ03 | 0.020 |
| | XCRF | L = 300 mm | XCRZ04 | 0.030 |
| Roller lever thermoplastic roller | XCRA XCRB | – | XCRZ02 | 0.050 |
| | XCRB | – | XCRZ05 | 0.090 |
| Large roller lever thermoplastic roller | XCRA XCRB | – | XCRZ05 | 0.090 |
| Quick fixing/ release bracket | XCRA, XCRB XCRE, XCRF | – | XCRZ09 | 0.520 |
| Contact block (2 contacts) with mounting plate | XCRA, XCRB XCRE, XCRF | 2-pole NC + NO snap action | XCRZ12 | 0.135 |
| | | 2-pole NC + NO break before make, snap action | XCRZ15 | 0.135 |

Limit switches

XC Special range

For conveyor belt shift monitoring applications, XCRT
Complete switches with 1 cable entry

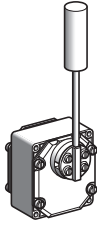
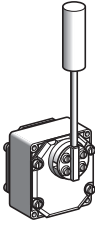
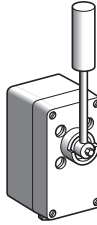
| Type of switch | Standard | For corrosive atmospheres | |
|----------------|--|---|---|
| |  |  |  |
| Features | Zinc alloy enclosure Colour: industrial blue Zinc plated steel lever, spring return to off position Cam angles: 10° and 18° Maximum displacement: 90° | Zinc alloy enclosure Colour: blue Stainless steel lever, spring return to off position Cam angles: 10° and 18° Maximum displacement: 90° | Glass reinforced polyester enclosure Colour: grey Stainless steel lever, spring return to off position Cam angles: 10° and 18° Maximum displacement: 70° |

References of complete switches

2 single-pole CO snap action

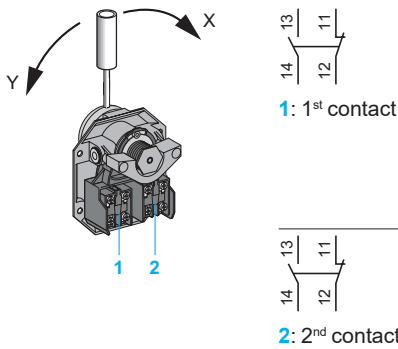

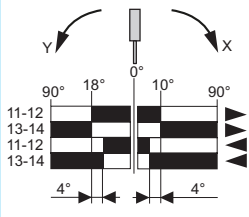
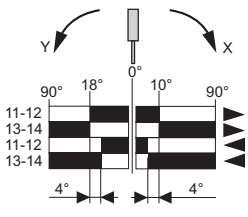
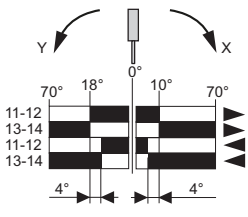
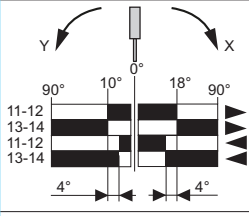
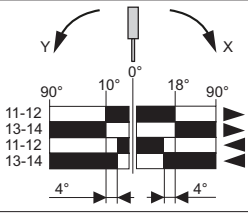
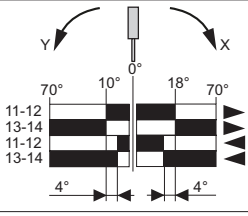
| | XCRT115 | XCRT215 | XCRT315 |
|-------------|---|--|---|
| |  |  |  |
| |  |  |  |
| Weight (kg) | 1.170 | 1.170 | 1.520 |

Contact operation  closed
 open

Complementary characteristics

| | |
|-------------------------------|--|
| Lever maximum actuation speed | 1.5 m/s |
| Belt maximum speed | 4 m/s |
| Machnical durability | 0.3 million operating cycles |
| Minimum tripping torque | 1.7 N.m |
| Cable entry | 1 entry tapped for Pg 13.5 cable gland conforming to NF C 68-300 (DIN Pg 13.5) Clamping capacity 9 to 12 mm |

Switch operation

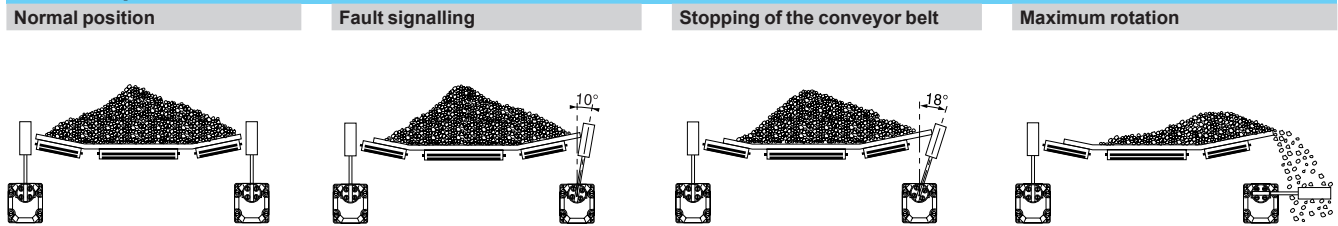

Limit switches

XC Special range

For conveyor belt shift monitoring applications,
XCRT

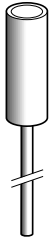

XCRZ9●●

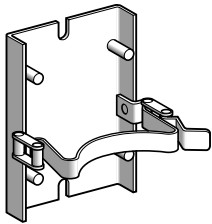

XCRZ09

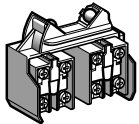

XCRZ42

Separate components

| Description | Type | For switches | Reference | Weight kg |
|--|----------------------------|--------------------|----------------|-----------|
| Roller with lever | Zinc plated steel | XCRT115 | XCRZ901 | 0.230 |
| | | XCRT215 | | |
| | Stainless steel | XCRT115 | XCRZ902 | 0.230 |
| | | XCRT215 | | |
| | | XCRT315 | XCRZ903 | 0.230 |
| Quick fixing/release bracket | – | XCRT115 XCRT215 | XCRZ09 | 0.520 |
| Contact block (2 contacts) with mounting plate | Single-pole CO snap action | XCRT●15 | XCRZ42 | 0.135 |

Limit switches

XC Special range

For hoisting and material handling applications, XCR

XCRA11, XCRB11, XCRA51, XCRB51

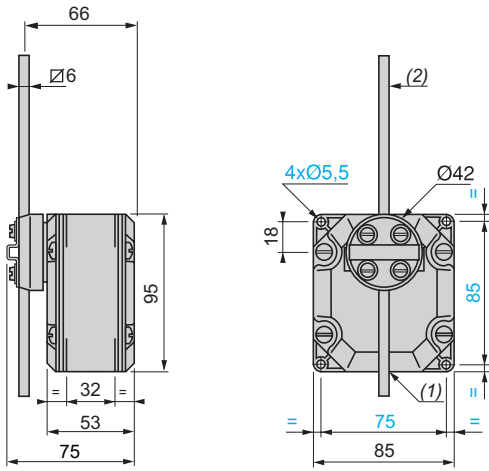

XCRA12, XCRB12, XCRA52, XCRB52

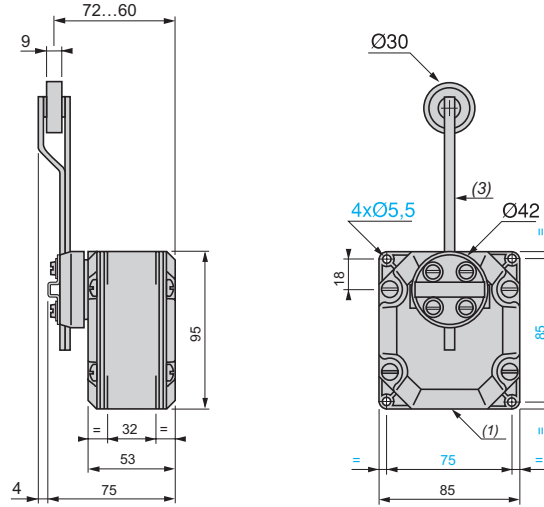

XCRA15, XCRB15, XCRA55, XCRB55

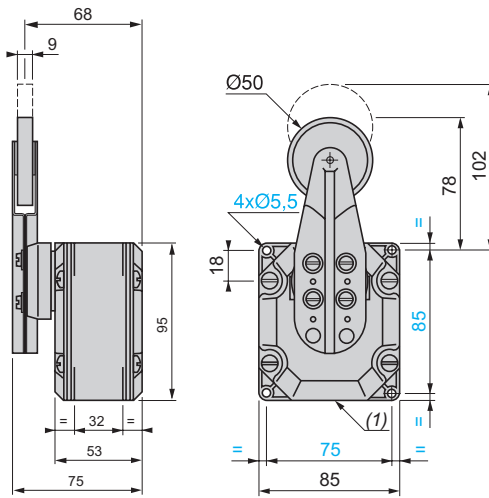

XCRE18, XCRE58, XCRF17, XCRF57

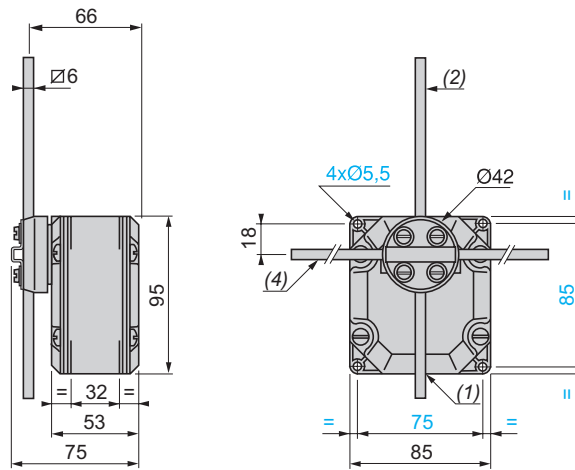

- (1) 1 tapped entry for Pg 13.5 cable gland.
- (2) Rod length: 200 mm.
- (3) Rod + roller length: 160 mm.
- (4) Rod length: 300 mm for XCRF17 and XCRF57, 200 mm for XCRE18 and XCRE58.

Supplementary fixing using 2 adjustable lugs (included with switch)

Horizontally positioned

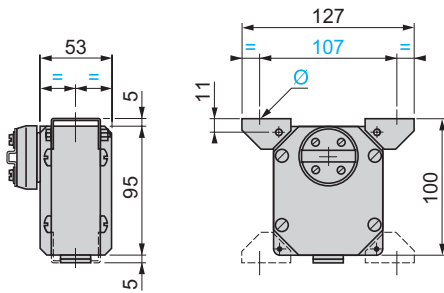

Vertically positioned

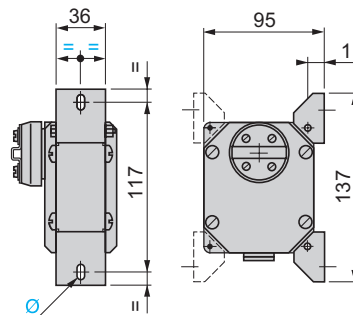

Quick fixing/release bracket XCRZ09

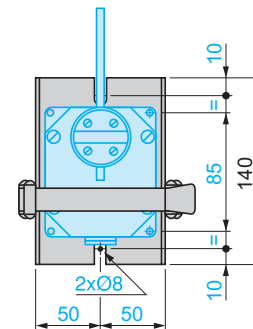

Ø: 1 elongated hole Ø 6 x 8.

Limit switches

XC Special range

For conveyor belt shift monitoring applications,
XCRT

XCRT115, XCRT215

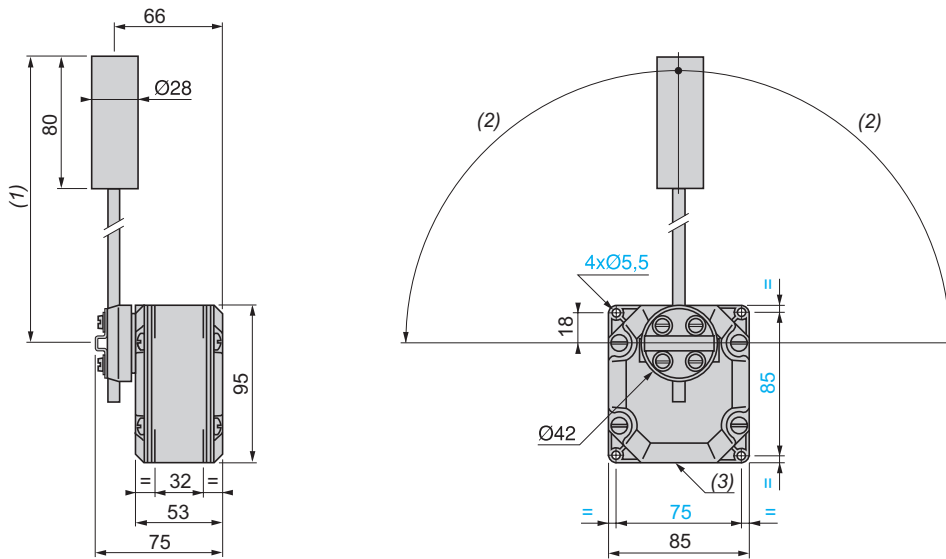

XCRT315

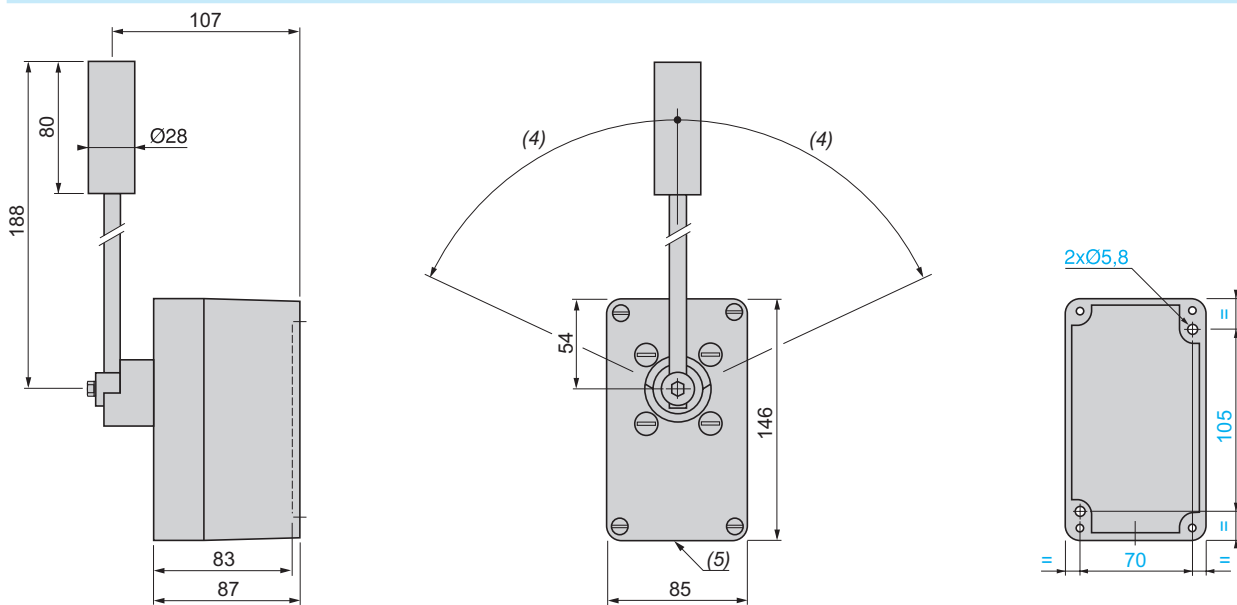

(1) 200 max., 104 min.

(4) 70° max.

(2) 90° max.

(5) 1 plain entry for Pg 13.5 cable gland.

(3) 1 tapped entry for Pg 13.5 cable gland.

Supplementary fixing using 2 adjustable lugs (included with XCRT115 and XCRT215)

Horizontally positioned

Vertically positioned

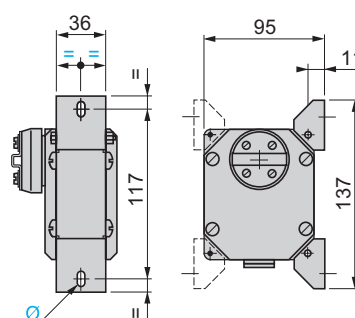
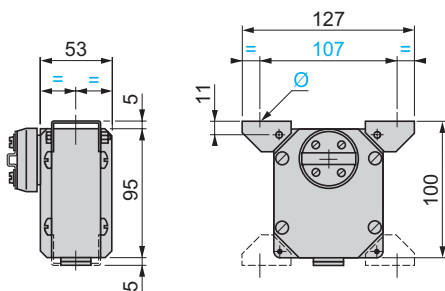

Quick fixing/release bracket XCRZ09

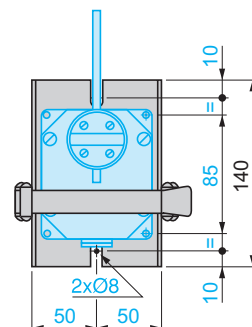

Ø: 1 elongated hole Ø 6 x 8.

Limit switches

XC Special range

For hoisting and material handling applications,

XCKMR and XCKVR

Complete switches with 3 cable entries

| Type of operating head | Rotary | | | |
|------------------------|--------|--|--|--|
| | | | | |

| | | | | |
|-------------------------|---------------------------|--|---------------------------|--|
| Material | Metal | | Plastic | |
| Type of operator | With cruciform metal rods | With cruciform metal rods, reversed head | With cruciform metal rods | With cruciform metal rods, reversed head |

References

“By pass” switches

| | | | | | |
|--|--|---------------|---|---------------|---|
| | 2 x 2-pole NC+NO break before make, slow break (XE2NP2151) | XCKMR24SR1H29 | – | XCKVR24SR1H29 | – |
|--|--|---------------|---|---------------|---|

“Single speed” switches

| | | | | | |
|--|--|--------------|--------------|--------------|--------------|
| | 2 x 2-pole NC+NO break before make, slow break (XE2NP2151) | XCKMR44D1H29 | XCKMR44D2H29 | XCKVR44D1H29 | XCKVR44D2H29 |
|--|--|--------------|--------------|--------------|--------------|

“Double speed” switches (⊖ NC contact with positive opening operation on contacts 21-22)

| | | | | | |
|--|---|------------------|------------------|--------------|--------------|
| | 2 x 2-pole NC+NC break before make, slow break (non interchangeable contacts) | XCKMR54D1H29 (1) | XCKMR54D2H29 (1) | XCKVR54D1H29 | XCKVR54D2H29 |
|--|---|------------------|------------------|--------------|--------------|

| | | | | |
|--------------------|-------|-------|-------|-------|
| Weight (kg) | 0.684 | 0.684 | 0.320 | 0.320 |
|--------------------|-------|-------|-------|-------|

Complementary characteristics

| | | | |
|---|---|----------------------------|---------------------|
| Switch actuation | Horizontal | Horizontal | |
| Permissible actuation area on the rods | Between 65 and 95 mm from the axis of the fixing screws on the body | | |
| Minimum actuation speed | 6 m/mn | 6 m/mn | |
| Maximum actuation speed (2) | 1.5 m/s | 1.5 m/s | |
| Minimum force or torque | For tripping For positive opening | 0.5 N.m 0.75 N.m | 0.5 N.m 0.75 N.m |
| Mechanical durability | 2 million operating cycles | 1 million operating cycles | |
| Setting up | Rods included with the switch: for customer assembly | | |

References of separate components

| | Description | Reference | Weight kg |
|--|--|-------------|-----------|
| | Rod \varnothing 6 mm, L = 200 mm | XCRZ03 | 0.020 |
| | Rod \varnothing 6 mm, L = 200 mm with red mark | XCRZ03R | 0.020 |
| | Plastic cable gland ISO M20 | DE9PEM20010 | 0.010 |

DE9PEM20010

(1) For complete switches with entry for Pg 13.5 cable gland, delete H29 from the end of the reference. Example: XCKMR54D1H29 becomes XCKMR54D1.

(2) For an actuation point on the rod between 65 and 95 mm from the axis of the fixing screws on the body.

Limit switches

XC Special range

For hoisting and material handling applications,

XCKMR and XCKVR

Complete switches with 3 cable entries

Dimensions

Metal limit switches

XCKMR24SR1H29,
XCKMR44D1H29 and
XCKMR54D1H29

XCKMR44D2H29 and
XCKMR54D2H29

Same front view

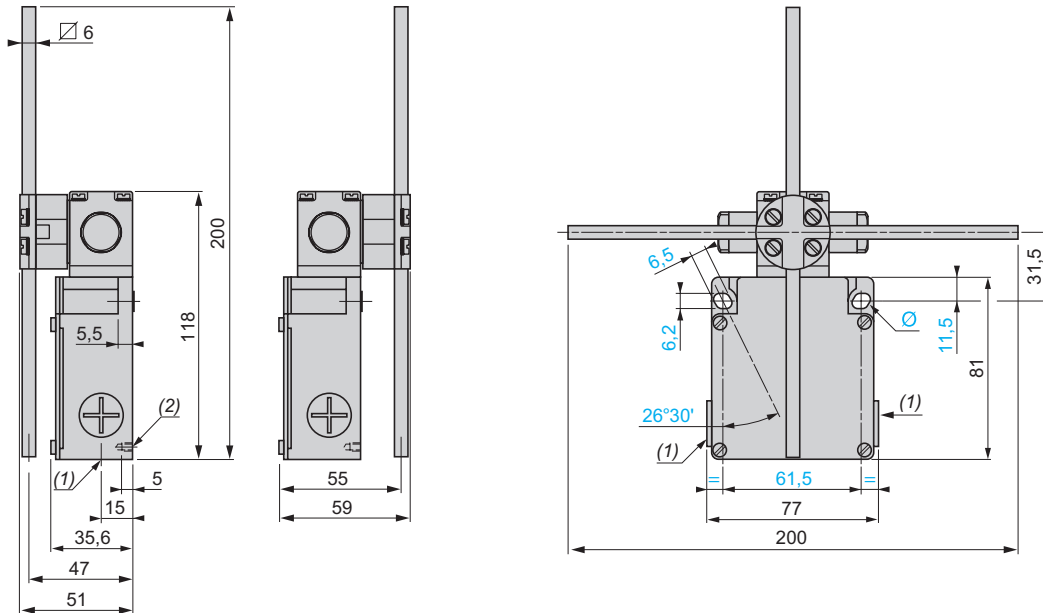

(1) XCKMR●●●●H29 = 3 tapped entries ISO M20 x 1.5.

XCKMR●●● = 3 tapped entries for Pg 13.5 cable gland.

(2) 2 centring holes $\varnothing 3.9 \pm 0.2$, for cover fixing holes alignment.

\varnothing : 2 elongated holes 6.2×6.5 , inclined at $26^{\circ}30'$ to the vertical axis, for M5 screws.

Plastic limit switches

XCKVR24SR1H29,
XCKVR44D1H29 and
XCKVR54D1H29

XCKVR44D2H29 and
XCKVR54D2H29

Same front view

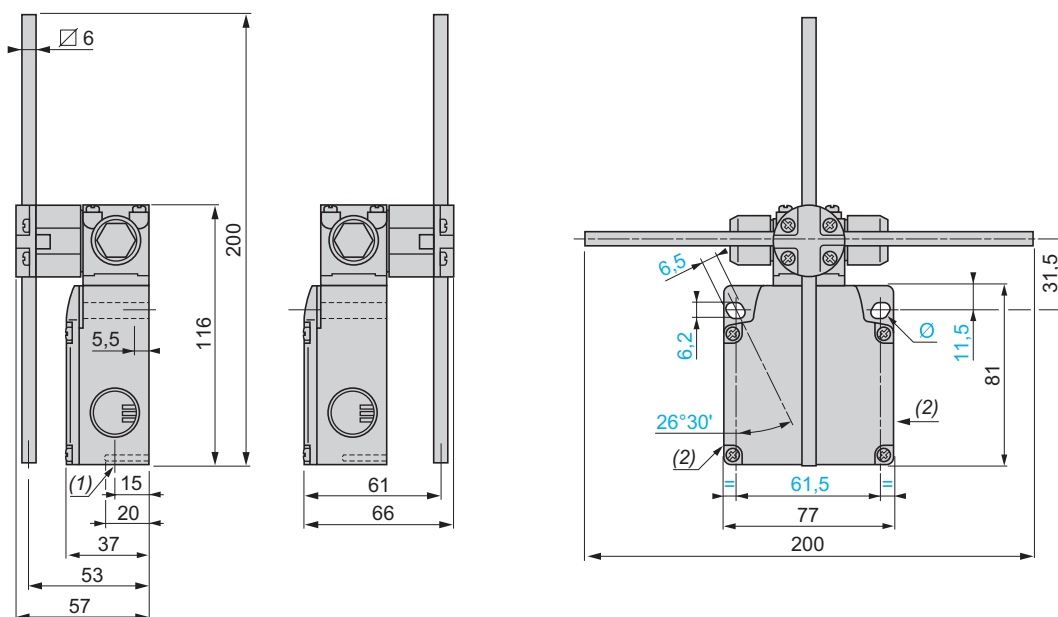

(1) 1 tapped entry ISO M20 x 1.5.

(2) 2 knock-out holes for ISO M20 cable gland (reference: DE9PEM20010).

\varnothing : 2 elongated holes 6.2×6.5 , inclined at $26^{\circ}30'$ to the vertical axis, for M5 screws.

Limit switches

XC Special range

For hoisting and material handling applications,

XCKMR and XCKVR

Complete switches with 3 cable entries

Operation

Limit switches XCK●R24SR1H29: "By pass"

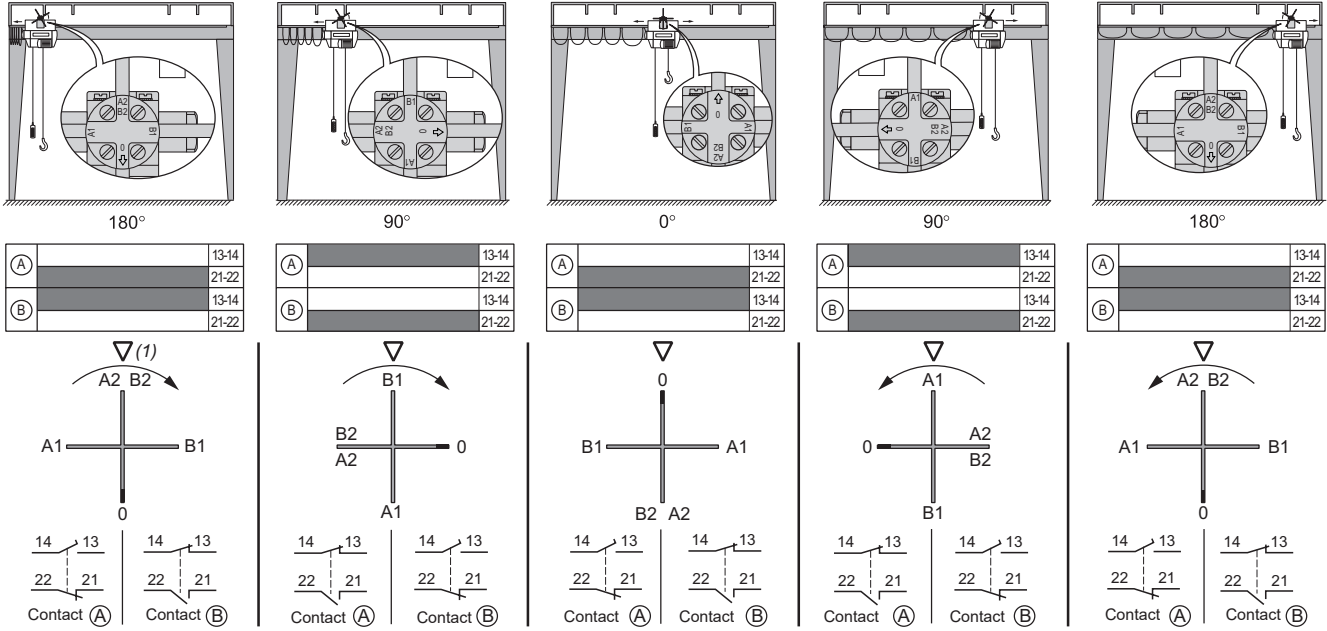

(1) Triangle symbol marked on top of head.

or : direction of rotation.

Limit switches XCK●R44D●H29: "Single speed"

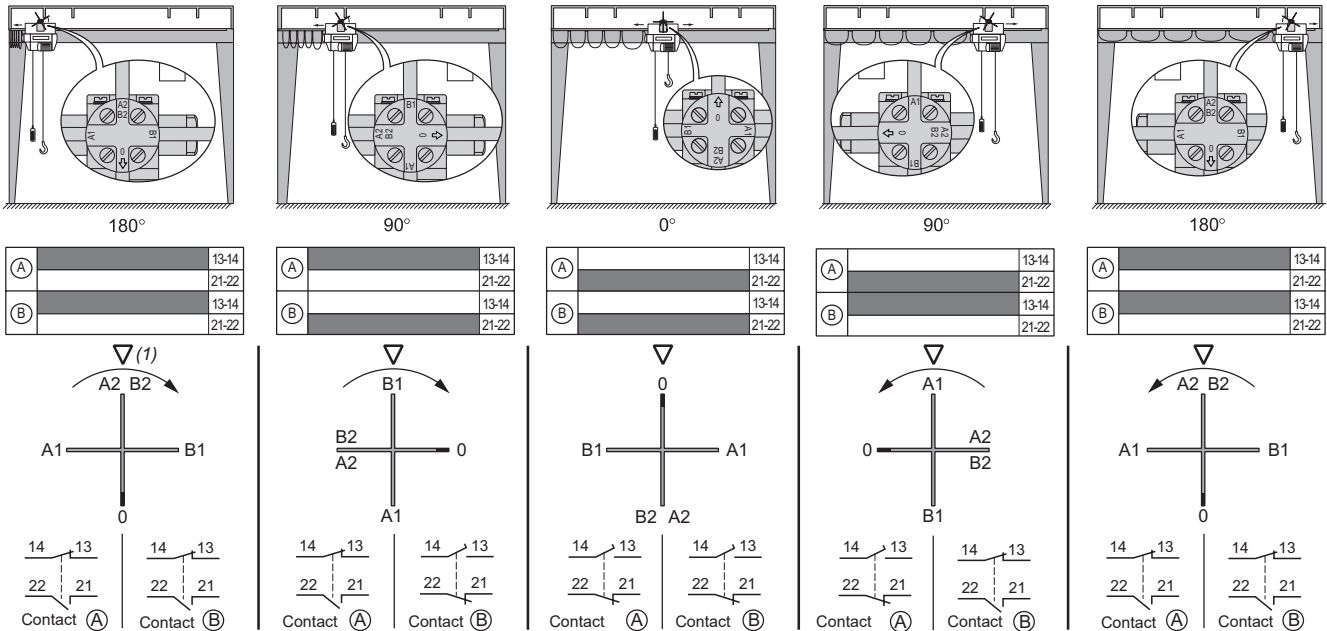

(1) Triangle symbol marked on top of head.

or : direction of rotation.

Limit switches

XC Special range

For hoisting and material handling applications,

XCKMR and XCKVR

Complete switches with 3 cable entries

Operation (continued)

Limit switches XCK●R54D●●●●: "Double speed"

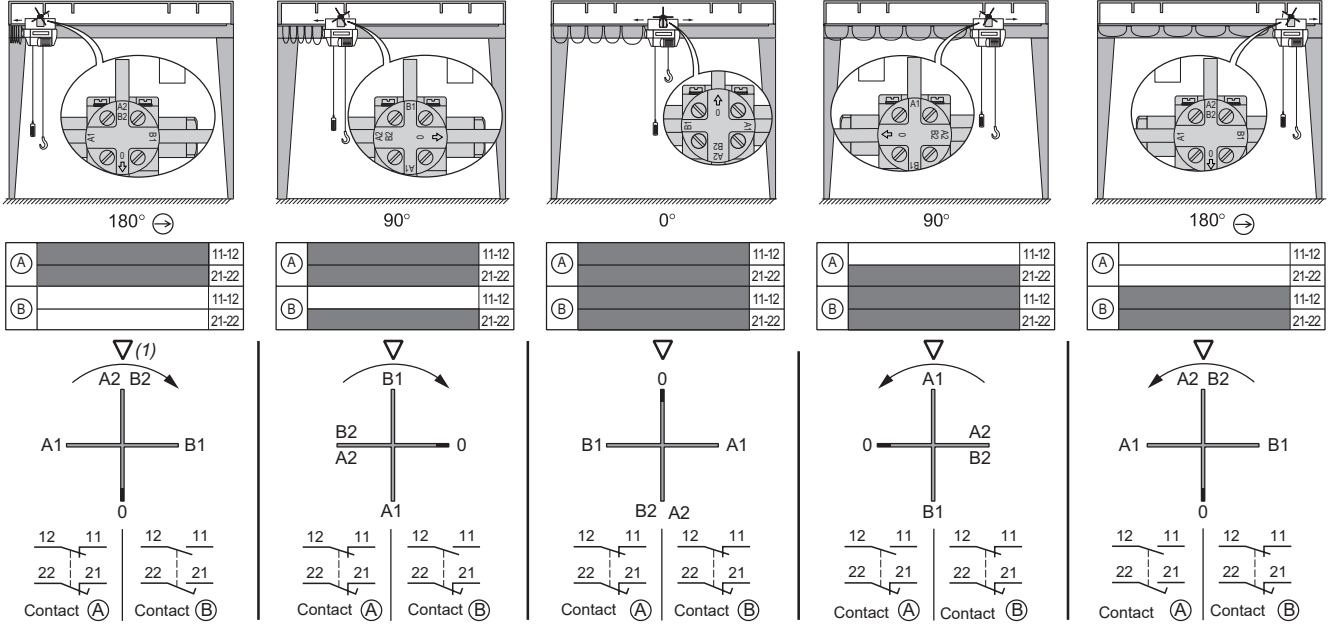

(1) Triangle symbol marked on top of head.

or : direction of rotation.

Presentation

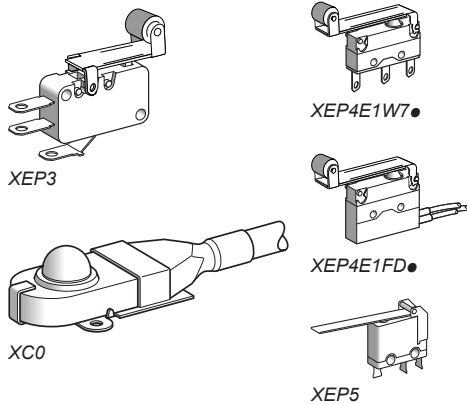

Terminology

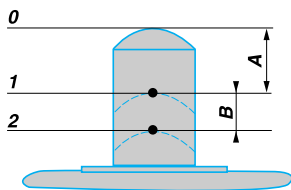

Mechanical characteristics

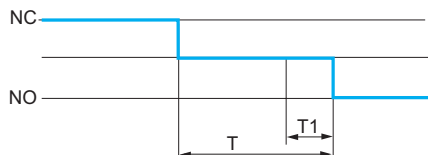

T1: bounce time
T: changeover time

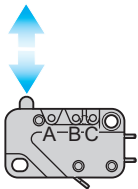

Mounting

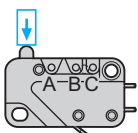

Electromechanical detection

- XC miniature snap switches, featuring electromechanical technology, assure the following functions:
 - detection of presence or absence,
 - detection of position.

Actuation of the operator (plunger or lever) on the miniature snap switch causes the electrical contact to change state. This information can then be processed by a PLC controlling the installation. XC miniature snap switches can be used both in industrial applications and the building sector.

Features

- XC miniature snap switches incorporate a CO snap action, single break, contact. They are characterised by:
 - high electrical ratings for their very small size,
 - short tripping travel,
 - low tripping force,
 - high repeat accuracy on the tripping points,
 - long service life.

Forces

- Maximum tripping force: maximum force which must be applied to the operator to move it from the rest (unactuated) position to the trip position (tripping point).
- Minimum release force: value to which the force on the operator must be reduced to allow the snap action mechanism to return to its rest (unactuated) position.
- Maximum permissible end of travel force: maximum force that can be applied to the operator at the end of its travel without damaging the switch.

Position/Travel

- 1 **Tripping point:** position of the operator in relation to the switch fixings (fixing hole centre line) at the instant the switch contact changes state.
- A **Differential travel:** distance between the tripping point and the position at which the snap action mechanism returns to its initial state on release of the operator.
- 2 **Overtravel limit:** position of the operator when an extreme force has moved it to the effective end of its available travel.
- B **Overtravel:** distance between the tripping point and the overtravel limit.

The reference point for the figures given for forces and travel is a point F, which is situated on the plunger in the case of a basic switch or at 3 mm from the end of the plain lever in the case of a lever operated switch.

Changeover time

- This is the time taken by the moving contact when moving from one fixed contact to another until it becomes fully stable (contact bounce included).
- This time is related to the inter-contact distance, the mechanical characteristics of the snap action mechanism and the mass of the moving element. However, due to the snap action mechanisms used, the time is largely independent to the speed of operation. It is normally less than 20 milliseconds (including bounce times of less than 5 ms).

Operating speed and maximum usable operating rate

- Our miniature snap switches are suitable for a wide range of operating speeds: generally, from 1 mm/mn to 1 m/s.
- The maximum usable operating rate on a light electrical load may be as high as 10 operations/second.

Mounting and operation

- To conform to the leakage paths and air gaps in standards EEC 24 - EN/IEC 61058 - EN/IEC 60947:
 - an insulation pad must be inserted between the snap switch and the fixing surface if the latter is metal.
 - manual operation of a metal actuator must only be carried out with the aid of an intermediate actuator made of an insulating material.
- The installer must ensure adequate protection against direct contact with the output terminals.

Actuation method

- Direct operation:
 - the plunger should preferably be actuated along its axis. However, the majority of our miniature snap switches will accept skewed operation provided the angle of actuation is not more than 45°.
- The travel of the actuator must not be limited to only reaching the tripping point. The actuator must always be operated in such a manner so that the plunger reaches a point at least 0.5 times the stated overtravel value of the switch. Steps must also be taken to ensure that it does not reach its end of travel nor exceed the maximum permissible end of travel force.

Characteristics (continued)

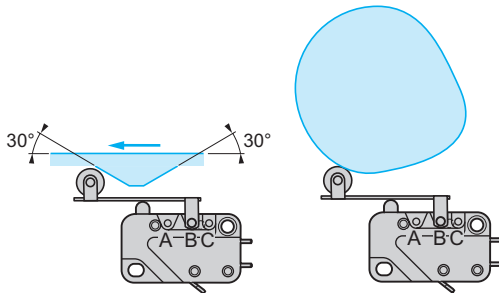

Actuation method (continued)

- Lever operators
 - when actuation is by a roller lever, force should preferably be applied in the direction shown in the diagrams opposite.
 - where the movements involved are fast, the ramp should be so designed as to ensure that the operator is not subjected to any violent impact or abrupt release.

Fixing - Tightening torque

- The tightening torque of the fixing screws must conform to the following values:

| Ø of fixing screw | | 2 | 2.5 | 3 | 3.5 | 4 |
|--------------------------|---------|----|-----|----|-----|-----|
| Tightening torque (cm.N) | Maximum | 25 | 35 | 60 | 100 | 150 |
| | Minimum | 15 | 25 | 40 | 60 | 100 |

Resistance to mechanical shock and vibration

- Resistance to shock and vibration depends on the mass of the moving parts and on the forces holding the contacts together.
- In general, for a miniature snap switch without accessory:
 - vibration > 10 gn, 10 to 500 Hz,
 - shock > 50 gn, 11 ms 1/2 sine wave.

Electrical characteristics

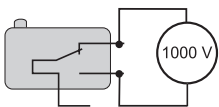
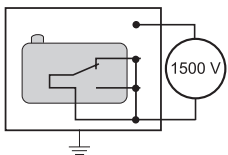
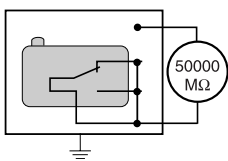
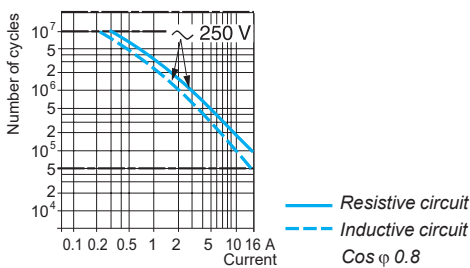

Operating curves

- These indicate the electrical life of the miniature snap switches under standard conditions (20°C, 1 cycle/2 seconds), by showing the number of switching operations which can be performed with given types of load. For sealed snap switches, the operating rate is 1 cycle/6s.

Insulation resistance

- The insulation resistance of the miniature snap switches is generally greater than 50,000 MΩ, measured at 500 V DC.

Dielectric strength

- The dielectric strength of our miniature snap switches is generally superior to:
 - 1500 Volts between live parts and earth,
 - 1000 Volts between contacts,
 - 600 Volts between contacts for switches with an inter-contact distance less than 0.3 mm.

Miniature snap switches

XC Special range

Subminiature design, DIN 41635 B format, sealed

References

Subminiature design, DIN 41635 B format, sealed

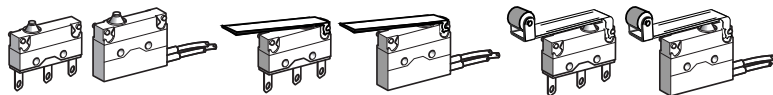

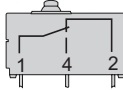
| Type of operator | | Plunger | Flat lever (1) | Roller lever (1) |
|--|--|--------------|------------------|------------------|
|  <p>Single-pole CO snap action Wiring: 1 Black 2 Grey 4 Blue</p> | 2.8 mm cable clip tag connections | XEP4E1W7 (2) | XEP4E1W7A326 (2) | XEP4E1W7A454 (2) |
| | Weight (g) | 2.4 | 3.1 | 3.2 |
| | Pre-cabled connections | XEP4E1FD (2) | XEP4E1FDA326 (2) | XEP4E1FDA454 (2) |
| | Weight (g) | 14.1 | 14.8 | 14.9 |

Dimensions

XEP4E1W7

XEP4E1W7A326

XEP4E1W7A454

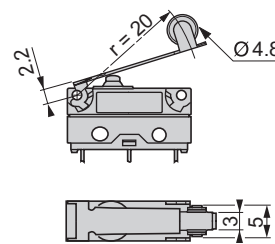
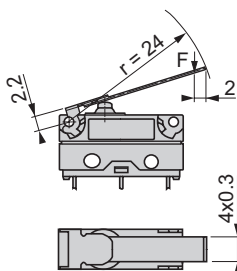
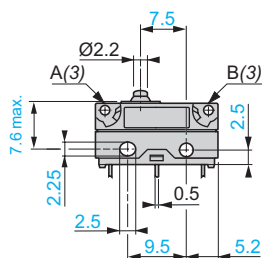
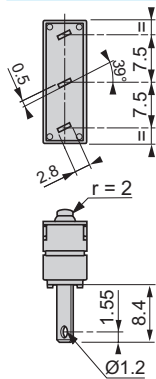

XEP4E1FD

XEP4E1FDA326

XEP4E1FDA454

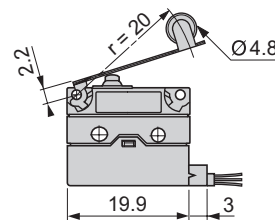
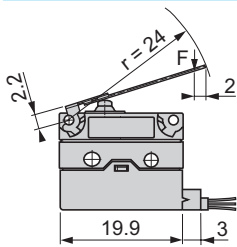
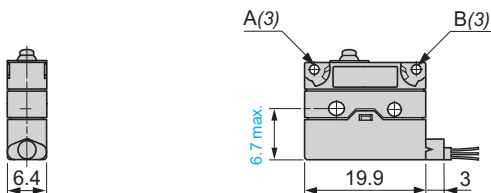

(1) In order to avoid damage to the fixing spigots, removal of the lever from complete products is not recommended.

(2) Switches sold in lots of 5.

(3) A, B: lever fixing positions.

Miniature snap switches

XC Special range

Subminiature design, DIN 41635 B format, sealed

| | | | | |
|------------------------------------|---|-------------------------------|-------------------------------|--|
| Switch type | XEP4E1W7, XEP4E1FD | XEP4E1W7A326, XEP4E1FDA326 | XEP4E1W7A454, XEP4E1FDA454 | |
| | Plunger | Flat lever | Roller lever | |
| Environment characteristics | | | | |
| Lever fixing position (1) | – | A | A | |
| Switch actuation | On end | Horizontal | | |
| Product certifications | CE, IEC 60947-5-1, EN 60947-5-1, c UR us, UL 1054, EN 61058 | | | |
| Degree of protection | IP 67 XEP4E1FD●●●, case IP 67 and tags IP 00 XEP4E1W7●●● | | | |
| Operating temperature | - 40...+ 105°C XEP4E1FD●●●, - 40...+ 125°C XEP4E1W●●● | | | |
| Materials | Case | Polyester | | |
| | Lever | – | Stainless steel | Stainless steel, glass reinforced polyamide roller |
| | Contact | AgCdO | | |
| | Tags | Tinned brass XEP4E1W7●●● | | |

| | | | | |
|---|----------------------------|---------------------------|---------------------------|---------------------------|
| Mechanical characteristics | | | | |
| | Lever fixing position (1) | | | |
| Maximum tripping force | A | 2.5 N | 0.63 N | 0.83 N |
| | B | 2.5 N | 1.25 N | 1.67 N |
| Minimum release force | A | 0.80 N | 0.20 N | 0.27 N |
| | B | 0.80 N | 0.40 N | 0.53 N |
| Maximum permissible end of travel force | A | 10 N | 2.5 N | 3.33 N |
| | B | 10 N | 5 N | 6.67 N |
| Tripping point (TP) (2) | A | 8.40 ^{+/-0.3} mm | 10.7 ^{+/-1.7} mm | 15.5 ^{+/-1.4} mm |
| | B | 8.40 ^{+/-0.3} mm | 9.6 ^{+/-1.0} mm | 14.5 ^{+/-0.9} mm |
| Maximum differential travel | A | 0.13 mm | 0.52 mm | 0.39 mm |
| | B | 0.13 mm | 0.26 mm | 0.20 mm |
| Minimum overtravel | A | 0.60 mm | 2.40 mm | 1.80 mm |
| | B | 0.60 mm | 1.20 mm | 0.90 mm |
| Inter-contact distance | 0.4 mm | | | |
| Mechanical durability | 2 million operating cycles | | | |

| | |
|-----------------------------------|--|
| Electrical characteristics | |
| Operational characteristics | AC-15: B300 (Ue: 240 V, Ie: 1.5 A) DC-13: R300 (Ue: 250 V, Ie: 0.1 A) conforming to IEC 60947-5-1, EN 60947-5-1 Appendix A 125-250 V AC 6.0 A conforming to UL 1054 6 (1) A 250 V AC 10 000 cycles conforming to EN 61058 |
| Thermal current | 7.5 A on 250 V (50/60 Hz) |
| Connection | XEP4E1W7 and XEP4E1W7●●●: 2.8 mm clip tags XEP4E1FD and XEP4E1FD●●●: pre-cabled (horizontally in-line), 3 x 0.5 mm ² , length 0.5 m |

Operating curves



(1) Miniature snap switches fitted with a lever are supplied with the lever fixed in position A (see page 58). For basic (plunger) snap switches, it is possible to fix the lever in position A or B, depending on the required tripping conditions (see page 58).

(2) Position of the operator in relation to the switch fixings (fixing hole centre line) at the instant the switch contact changes state.

References

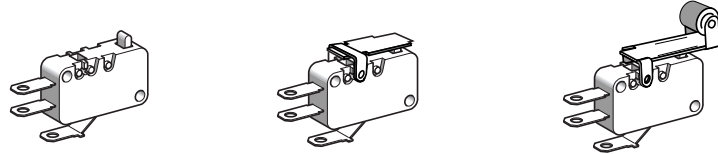

| Type of operator | | Plunger | Flat lever (1) | Roller lever (1) | |
|-----------------------------------|-----------------------------------|-------------------------|------------------|------------------|------------------|
| <p>Single-pole CO snap action</p> | Standard contacts | Solder tags | XEP3S1W2 (2) | XEP3S1W2B524 (2) | |
| | | 4.8 mm cable clip tags | XEP3S1W6 (2) | XEP3S1W6B524 (2) | |
| | | 6.35 mm cable clip tags | XEP3S1W3 (2) | XEP3S1W3B524 (2) | |
| | | Weight (g) | 5.6 | 6.3 | 6.6 |
| | Very low operating force contacts | Solder tags | — | XEP3S2W2B524 (2) | XEP3S2W2B529 (2) |
| | | 4.8 mm cable clip tags | XEP3S2W6 (2) | — | XEP3S2W6B529 (2) |
| 6.35 mm cable clip tags | | XEP3S2W3 (2) | XEP3S2W3B524 (2) | XEP3S2W3B529 (2) | |
| | Weight (g) | 5.6 | 6.3 | 6.6 | |
| Separate components | Flat lever (3) | ZEP3L524 (2) | | | |
| | Weight (g) | 0.7 | | | |

Dimensions

XEP3S●W2

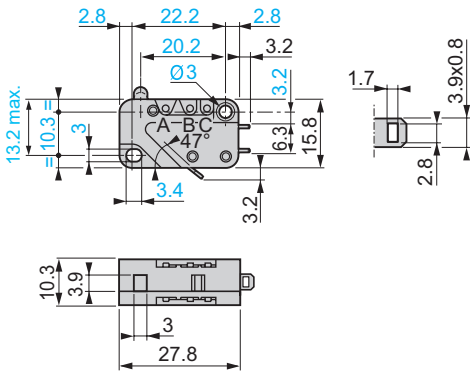

XEP3S●W6

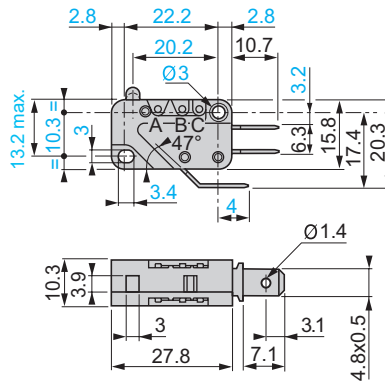

XEP3S●W3

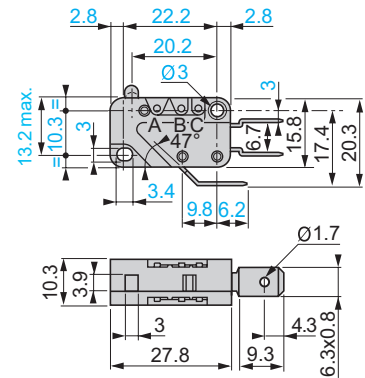

ZEP3L524

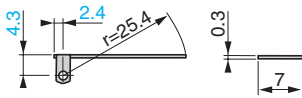

(1) In order to avoid damage to the fixing spigots, removal of the lever from complete products is not recommended.

(2) Switches sold in lots of 10.

(3) Levers only for mounting on basic (plunger) snap switches (XEP3S●W2, XEP3S●W3, XEP3S●W6), in fixing positions A, B or C.

| Switch type Type of operator | XEP3S●W● Plunger | XEP3S●W2B254 Flat lever | XEP3S●W2B259 Roller lever |
|------------------------------------|--|----------------------------|--|
| Environment characteristics | | | |
| Lever fixing position (1) | – | B | B |
| Switch actuation | On end | Horizontal | |
| Product certifications | UR us, CE, IEC/EN 60947-5-1, UL 1054, EN 61058-1 | | |
| Degree of protection | Case IP 40 and tags IP 00 | | |
| Operating temperature | - 25...+ 125°C | | |
| Materials | Case | Polyester | |
| | Lever | – | Stainless steel |
| | Contact | AgNi | Stainless steel, glass reinforced polyamide roller |

| Mechanical characteristics | | | |
|--|---------------------------|-----------------------------|----------------------------|
| | Lever fixing position (1) | | |
| Maximum tripping force | Standard | A | 0.8 N |
| | | B | 0.8 N |
| | | C | 0.8 N |
| | Very low force | A | 0.25 N |
| | | B | 0.25 N |
| | | C | 0.25 N |
| Minimum release force | Standard | A | 0.20 N |
| | | B | 0.20 N |
| | | C | 0.20 N |
| | Very low force | A | 0.05 N |
| | | B | 0.05 N |
| | | C | 0.05 N |
| Maximum permissible end of travel force | Standard, very low force | A | 20 N |
| | B | 20 N | |
| | C | 20 N | |
| Tripping point (TP) (2) | Standard, very low force | A | 14.70 ^{+/-0.4} mm |
| | | B | 14.70 ^{+/-0.4} mm |
| | | C | 14.70 ^{+/-0.4} mm |
| Maximum differential travel | Standard, very low force | A | 0.35 mm |
| | | B | 0.35 mm |
| | | C | 0.35 mm |
| Minimum overtravel | Standard | A | 1.20 mm |
| | | B | 1.20 mm |
| | | C | 1.20 mm |
| | Very low force | A | 1.10 mm |
| | | B | 1.10 mm |
| | | C | 1.10 mm |
| Inter-contact distance | | | 0.40 mm |
| Mechanical durability for 2/3 overtravel | Standard | 20 million operating cycles | |
| | Very low force | 50 million operating cycles | |

| Electrical characteristics | | |
|-----------------------------------|--|--|
| Operational characteristics | Standard | AC-15: B300 (Ue: 240 V, Ie: 1.5 A) DC-13: R300 (Ue: 250 V, Ie: 0.1 A) conforming to IEC/EN 60947-5-1 Appendix A 125-250 V AC 10,1 A - 1/2 HP conforming to UL 1054 12 (3) A 250 V AC 10 000 cycles conforming to EN 61058-1 |
| | Very low force | AC-15: D300 (Ue: 240 V, Ie: 0.3 A) conforming to IEC/EN 60947-5-1 Appendix A 125-250 V AC 4 A - 1/10 HP conforming to UL 1054 4 (1) A 250 V AC 50 000 cycles conforming to EN 61058-1 |
| Thermal current | Standard | 15 A on 250 V (50/60 Hz) |
| | Very low force | 5 A on 250 V (50/60 Hz) |
| Connection | XEP3S●W2: solder tags, XEP3S●W6: 4.8 mm cable clip tags, XEP3S●W3: 6.35 mm cable clip tags | |

Operating curves

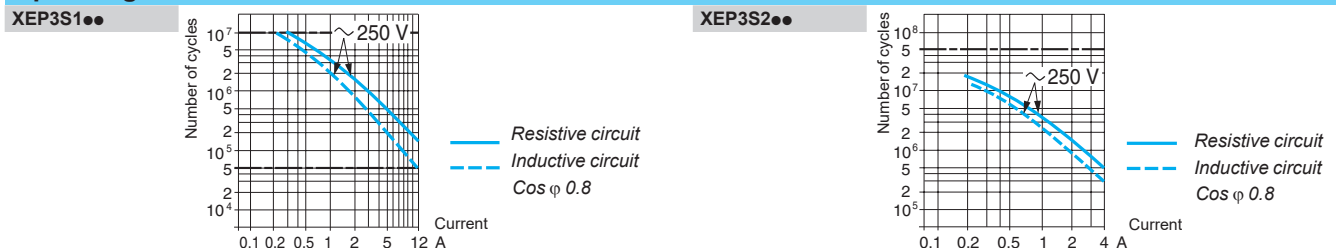

(1) Miniature snap switches fitted with a lever are supplied with the lever fixed in position B (see page 60). For basic (plunger) snap switches, it is possible to fix the lever in position A, B or C, depending on the required tripping conditions (see page 60).

(2) Position of the operator in relation to the switch fixings (fixing hole centre line) at the instant the switch contact changes state.

Miniature snap switches

XC Special range

Sealed design

Pre-cabled

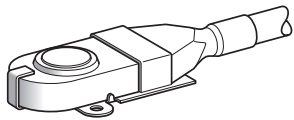
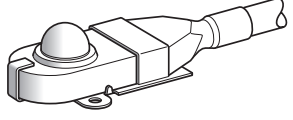
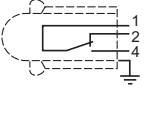
| Type of head | Plunger (fixing by the body) | |
|---|---|----------------------------------|
|  |  | |
| Type of operator | Head with flat plunger | Head with domed enclosed plunger |
| References | | |
|  <p data-bbox="284 591 422 703">Single-pole CO snap action Wiring: 1 Black 2 Brown 4 Blue</p> | XC010L2 | XC011L2 |
| Weight (kg) | 0.145 | 0.150 |
| Dimensions | | |
| XC010L2 | | |

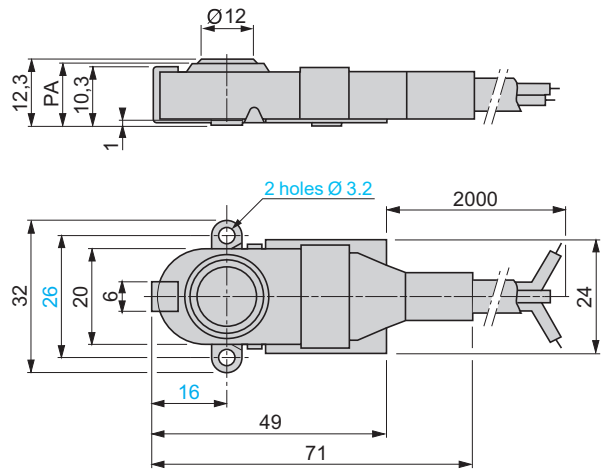

XC011L2

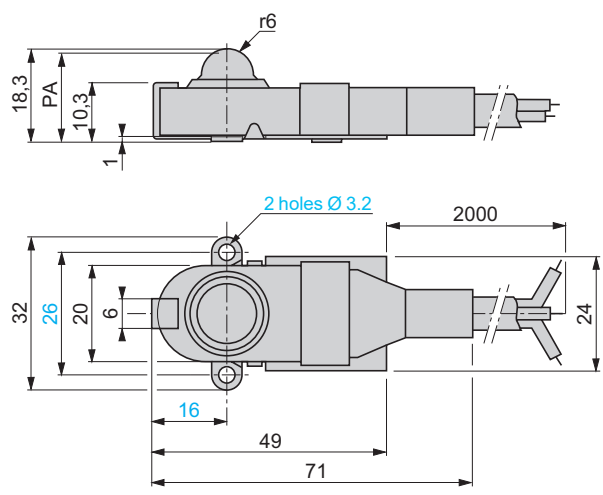

Miniature snap switches

XC Special range

Sealed design

Pre-cabled

| Switch type | XC010L2 | XC011L2 |
|---|---|---------------------------|
| Environment characteristics | | |
| Switch actuation | On end, flat plunger (1) | On end, domed plunger (1) |
| Product certifications | CE, IEC 60947-5-1 | |
| Degree of protection | IP 66 | |
| Operating temperature | 0...+ 85°C | |
| Materials | Internal housing | Metal |
| | Casing | Nitrile |
| | Fixing support | Steel, zinc passivated |
| | Contact | Ag |
| Mechanical characteristics | | |
| Maximum tripping force | 5.3 N | |
| Minimum release force | 1.5 N | |
| Maximum permissible end of travel force | 30 N | |
| Tripping point (TP) (2) | 11.4 ^{±0.4} mm | 17.4 ^{±0.5} mm |
| Maximum differential travel | 0.2 mm | |
| Minimum overtravel | 0.2 mm | |
| Inter-contact distance | 0.5 mm | |
| Mechanical durability | 2 million operating cycles | |
| Electrical characteristics | | |
| Operational current | 1 A on 24 V (50/60 Hz) | |
| Thermal current/insulation voltage | 12 A/60 V | |
| Connection | A05 VVF cable, 3 x 0.75 mm ² , length 2 metres, external diameter ≤ 7.6 mm | |
| Electrical durability | AC-15: 0.5 million operating cycles | |

(1) Manual actuation must be made by an intermediate insulated part, in order to meet basic safety requirements.

One of the two fixing holes must also be used as an earth protection terminal.

(2) Distance between the base of the switch and the top of the plunger at the instant the contact changes state (see dimensions, page 62).



XUF9D●●●



XUF9F●●●

Functions

The overtravel limit switches for power circuit switching are specifically designed to ensure the safety of hoisting equipment.

They directly break the power supply to the hoist motor if the load being handled accidentally exceeds the operating limits of the equipment.

Their mechanism is designed to ensure breakage of the power supply in the event of a malfunction and therefore, an overtravel limit switch cannot be used in place of an end of travel limit switch. It must only be used as a back-up device in the event of failure of the latter, or any other component forming part of an automated control circuit monitoring for excessive overtravel.

Description

XF9D●●● overtravel limit switches are housed in an aluminium alloy case.

XF9F●●● overtravel limit switches are housed in a sheet steel enclosure.

They are equipped with power contacts from Schneider Electric contactors.

Operation

Mounting and operating precautions

It is recommended that the overtravel limit switch be connected as near as possible to the motor, in order to minimise the risk of shunting.

The switch must be positioned in such a manner so as to avoid any damage in the event of the load exceeding the end of travel limits.

In order to ensure positive operation, the operating lever of the overtravel limit switch must be actuated directly by the moving part being monitored. It is essential that the use of any flexible or deformable intermediate actuators be avoided.

Manual reset switches - resetting after tripping

- Before resetting the overtravel limit switch ensure that the cause of its tripping is located and rectified.
- Rotate and hold lever up against end stop.
- Simultaneously press the reset button (XF9D), using accessory included with switch, or operate the reset lever (XF9F) and turn the control station switch away from the trip position.
- Rotate lever back to its initial position.

| Environment | | | | | | | | |
|--|--|--------------|--|--|---|------------------------------|------------------------|-----|
| Overtravel limit switch type | | | XF9D251 | XF9D651 | XF9F1151 XF9F1152 | XF9F1851 XF9F1852 | XF9F2651 XF9F2652 | |
| Conformity to standards | | | IEC 60158-1, NF C 63-110, VDE 0660, IEC 60947-1, IEC 60947-4 | | | | | |
| Product certification | 3-phase | | CSA | | | | | |
| | | | 20 HP 40 A, 600 V | 20 HP 80 A, 600 V | 100 HP 175 A, 600 V | 150 HP 40 A, 200 A, 600 V | 200 HP 428 A, 600 V | |
| | Single-phase, 2-pole | | 3 HP 40 A, 230 V | 10 HP 80 A, 230 V | – | – | – | |
| Protective treatment | Standard version | | "TC" | | | | | |
| | Special version | | "TH" on request | | | | | |
| Ambient air temperature | For storage | °C | - 40...+ 70 | | | | | |
| | For operation | °C | - 25...+ 70 | | | | | |
| Degree of protection | Conforming to IEC/EN 60529 | | IP 54 | | IP 43 | | | |
| Housing | | | Aluminium alloy case | | Sheet steel enclosure | | | |
| Cable entry | | | 2 tapped entries for n° 21 cable gland | 3 tapped entries for n° 29 cable gland | 2 entries incorporating n° 36 plastic cable gland | | | |
| Contact block characteristics | | | | | | | | |
| Number of poles | | | 4 | | 3 | | | |
| Rated operational current (Ie) | For 2-pole scheme | A | 50 | 130 | – | – | – | |
| | For 3-pole scheme on AC-3 | A | 25 | 65 | 115 | 185 | 265 | |
| Conventional thermal current (Ithe) at $\theta \leq 40$ °C | For 2-pole scheme | A | 80 | 160 | – | – | – | |
| | For 3-pole scheme | A | 40 | 80 | 200 | 275 | 350 | |
| Rated insulation voltage (Ui) | Conforming to IEC 60158-1, IEC 947-4, VDE 0110 Group C | V | 500 | | 660 | | | |
| | Conforming to CSA 22-2 n° 14 | V | 600 | | | | | |
| Rated breaking capacity (I rms) | Conforming to IEC 60158-1 500 V | A | 400 | 1000 | 1100 | 1600 | 2200 | |
| | For 2-pole scheme 660 V | A | 180 | 630 | 900 | 1200 | 1750 | |
| Connection Min./max. cable c.s.a. | Flexible wiring, without cable end | 1 conductor | mm ² | 1.5/10 | 2.5/25 | – | – | – |
| | | 2 conductors | mm ² | 1.5/6 | 2.5/16 | – | – | – |
| | Flexible wiring, with cable end | 1 conductor | mm ² | 1/6 | 2.5/16 | – | – | – |
| | | 2 conductors | mm ² | 1/4 | 2.5/6 | – | – | – |
| | Solid wiring, without cable end | 1 conductor | mm ² | 1.5/6 | 2.5/25 | – | – | – |
| | | 2 conductors | mm ² | 1.5/6 | 4/16 | – | – | – |
| | Cable | 1 conductor | mm ² | – | – | 95 | 150 | 240 |
| | | 2 conductors | mm ² | – | – | 95 | 150 | 240 |



XF9D251

References of overtravel limit switches

Switches without auxiliary contact block

| Description | Rated operational current A | Conventional thermal current A | Disconnection | Reference | Weight kg |
|---|--------------------------------|-----------------------------------|------------------|-----------|--------------|
| With manual latching and resetting restricted by a padlockable device Snap action opening mechanism Maximum travel: 75° in each direction | 25 | 40 | 3-pole or 4-pole | XF9D251 | 2.200 |
| | or | or | 2-pole | | |
| | 50 | 80 | 3-pole or 4-pole | XF9D651 | 5.000 |
| | or | or | 2-pole | | |
| With manual latching and resetting Horizontal or vertical actuation Snap action opening mechanism | 115 | 200 | 3-pole | XF9F1151 | 25.500 |
| | 185 | 275 | 3-pole | XF9F1851 | 26.000 |
| | 265 | 350 | 3-pole | XF9F2651 | 27.500 |
| With counterweights and automatic resetting Horizontal or vertical actuation Slow break opening mechanism Minimum actuation speed: 2.5m/s | 115 | 200 | 3-pole | XF9F1152 | 28.500 |
| | 185 | 275 | 3-pole | XF9F1852 | 29.000 |
| | 265 | 350 | 3-pole | XF9F2652 | 32.500 |

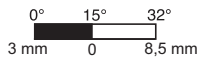
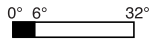
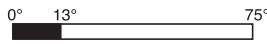

XF9F...2

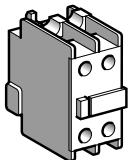

LADN11

References of accessories (Schneider Electric products)

| Auxiliary contact blocks | | | | |
|--------------------------|-----------------------|-----------|--------------|--|
| Description | For use with switches | Reference | Weight kg | |
| N/C + N/O instantaneous | XF9F...●● | LADN11 | 0.030 | |

Replacement parts

| Description | For use with switches | Reference | Weight kg |
|---|-----------------------|-----------|--------------|
| Contact set comprising per pole: - 2 fixed contacts, - 1 moving contact, - 2 deflectors, - 1 backplate, clamping screw and washers | XF9F115● | LA5FF431 | 0.270 |
| | XF9F185● | LA5FG431 | 0.350 |
| | XF9F265● | LA5FH431 | 0.660 |
| Arc chambers | XF9F115● | LA511550 | 0.490 |
| | XF9F185● | LA518550 | 0.670 |
| | XF9F265● | LA526550 | 0.920 |

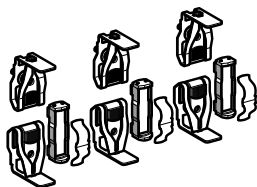

LA5FG431

■ Contacts closed
□ Contacts open

Dimensions

XF9D251

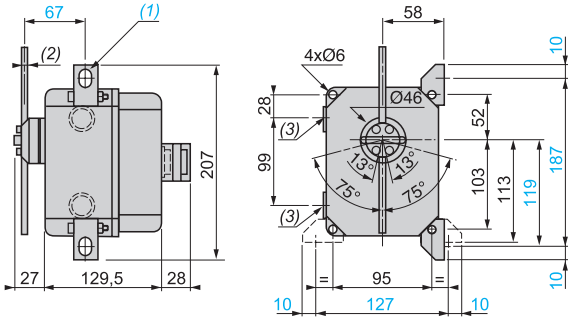

XF9D651

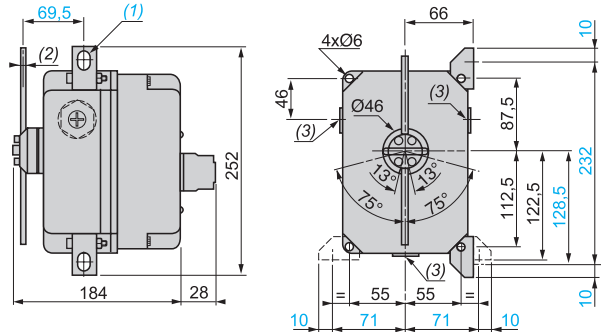

- (1) 2 elongated holes $\text{Ø} 6 \times 8.5$ (removable fixing lugs).
- (2) 6 mm square rod, length 200 (can be mounted at 90°).
- (3) 2 tapped entries for n° 21 cable gland.
- 13° = contact actuation, 75° = maximum travel.

- (1) 2 elongated holes $\text{Ø} 6 \times 8.5$ (removable fixing lugs).
- (2) 6 mm square rod, length 200 (can be mounted at 90°).
- (3) 3 plain entries for n° 29 cable gland.
- 13° = contact actuation, 75° = maximum travel.

XF9F●●●1

Manual resetting

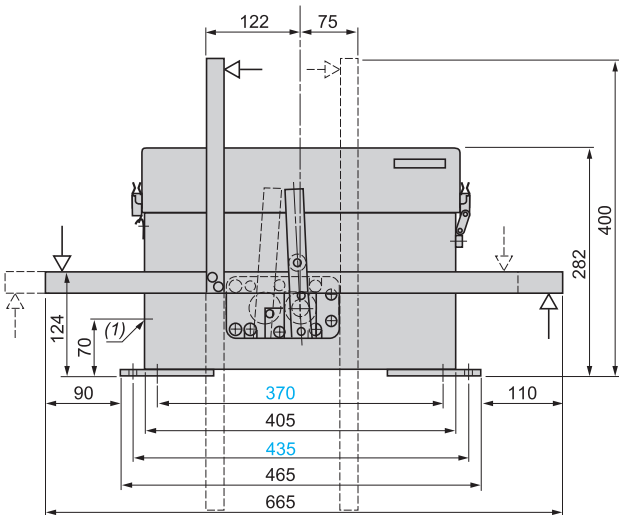

XF9F●●●2

Automatic resetting

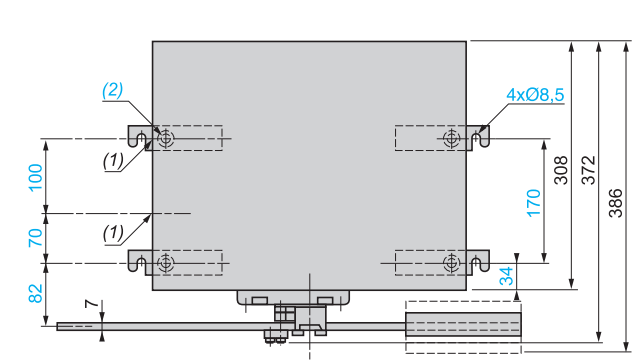
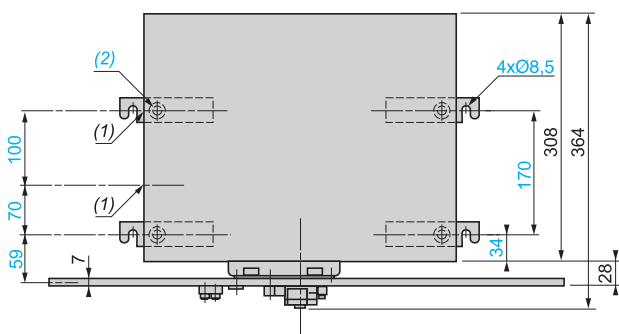
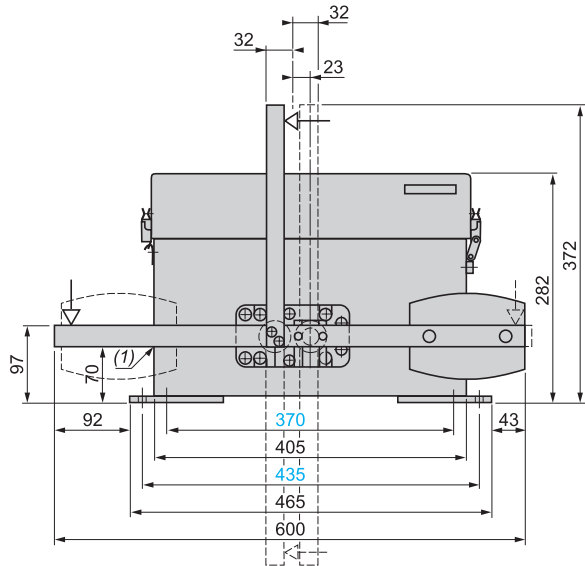

- (1) 2 entries incorporating n° 36 plastic cable gland.
- (2) 4 holes $\text{Ø} 8.5$ to be drilled by user (for attaching fixing lugs to enclosure base).

- (1) 2 entries incorporating n° 36 plastic cable gland.
- (2) 4 holes $\text{Ø} 8.5$ to be drilled by user (for attaching fixing lugs to enclosure base).

По вопросам продаж и поддержки обращайтесь:

Алматы (727)345-47-04
Ангарск (3955)60-70-56
Архангельск (8182)63-90-72
Астрахань (8512)99-46-04
Барнаул (3852)73-04-60
Белгород (4722)40-23-64
Благовещенск (4162)22-76-07
Брянск (4832)59-03-52
Владивосток (423)249-28-31
Владикавказ (8672)28-90-48
Владимир (4922)49-43-18
Волгоград (844)278-03-48
Вологда (8172)26-41-59
Воронеж (473)204-51-73
Екатеринбург (343)384-55-89

Иваново (4932)77-34-06
Ижевск (3412)26-03-58
Иркутск (395)279-98-46
Казань (843)206-01-48
Калининград (4012)72-03-81
Калуга (4842)92-23-67
Кемерово (3842)65-04-62
Киров (8332)68-02-04
Коломна (4966)23-41-49
Кострома (4942)77-07-48
Краснодар (861)203-40-90
Красноярск (391)204-63-61
Курск (4712)77-13-04
Курган (3522)50-90-47
Липецк (4742)52-20-81

Магнитогорск (3519)55-03-13
Москва (495)268-04-70
Мурманск (8152)59-64-93
Набережные Челны (8552)20-53-41
Новокузнецк (3843)20-46-81
Ноябрьск (3496)41-32-12
Новосибирск (383)227-86-73
Омск (3812)21-46-40
Орел (4862)44-53-42
Оренбург (3532)37-68-04
Пенза (8412)22-31-16
Петрозаводск (8142)55-98-37
Псков (8112)59-10-37
Пермь (342)205-81-47

Ростов-на-Дону (863)308-18-15
Рязань (4912)46-61-64
Самара (846)206-03-16
Санкт-Петербург (812)309-46-40
Саратов (845)249-38-78
Севастополь (8692)22-31-93
Саранск (8342)22-96-24
Симферополь (3652)67-13-56
Смоленск (4812)29-41-54
Сочи (862)225-72-31
Ставрополь (8652)20-65-13
Сургут (3462)77-98-35
Сыктывкар (8212)25-95-17
Тамбов (4752)50-40-97
Тверь (4822)63-31-35

Тольятти (8482)63-91-07
Томск (3822)98-41-53
Тула (4872)33-79-87
Тюмень (3452)66-21-18
Ульяновск (8422)24-23-59
Улан-Удэ (3012)59-97-51
Уфа (347)229-48-12
Хабаровск (4212)92-98-04
Чебоксары (8352)28-53-07
Челябинск (351)202-03-61
Череповец (8202)49-02-64
Чита (3022)38-34-83
Якутск (4112)23-90-97
Ярославль (4852)69-52-93

Россия +7(495)268-04-70

Казахстан +(727)345-47-04

Беларусь +(375)257-127-884

Узбекистан +998(71)205-18-59

Киргизия +996(312)96-26-47

эл.почта: tuq@nt-rt.ru || сайт: <https://telemecanique.nt-rt.ru>